



# User's Manual

## Brute MagnaTech® HTD

### 20:1 Turndown.

#### Boiler

Model BMGH1600 1,600 MBTU/h
Model BMGH2000 1,999 MBTU/h
Model BMGH2500 2,499 MBTU/h
Model BMGH3000 3,000 MBTU/h
Model BMGH3500 3,500 MBTU/h
Model BMGH4000 4,000 MBTU/h

#### Water Heater

Model BMGV1600 1,600 MBTU/h
Model BMGV2000 1,999 MBTU/h
Model BMGV2500 2,499 MBTU/h
Model BMGV3000 3,000 MBTU/h
Model BMGV3500 3,500 MBTU/h
Model BMGV4000 4,000 MBTU/h

**FOR YOUR SAFETY:** This product must be installed and serviced by a professional service technician, qualified in hot water boiler and heater installation and maintenance. Improper installation and/or operation could create carbon monoxide gas in flue gases which could cause serious injury, property damage, or death. Improper installation and/or operation will void the warranty.

#### **⚠ WARNING**

If the information in this manual is not followed exactly, a fire or explosion may result causing property damage, personal injury or loss of life.

Do not store or use gasoline or other flammable vapors and liquids in the vicinity of this or any other unit.

##### WHAT TO DO IF YOU SMELL GAS

- Do not try to light any unit.
- Do not touch any electrical switch; do not use any phone in your building.
- Immediately call your gas supplier from a nearby phone. Follow the gas supplier's instructions.
- If you cannot reach your gas supplier, call the fire department.

Installation and service must be performed by a qualified installer, service agency, or gas supplier.

#### **⚠ AVERTISSEMENT**

Assurez-vous de bien suivre les instructions données dans cette notice pour réduire au minimum le risque d'incendie ou d'explosion ou pour éviter tout dommage matériel, toute blessure ou la mort.

Ne pas entreposer ni utiliser d'essence ni d'autres vapeurs ou liquides inflammables dans le voisinage de cet appareil ou de tout autre appareil.

##### QUE FAIRE SI VOUS SENTEZ UNE ODEUR DE GAZ:

- Ne pas tenter d'allumer d'appareils.
- Ne touchez à aucun interrupteur. Ne pas vous servir des téléphones dans le bâtiment où vous êtes.
- Appelez immédiatement votre fournisseur de gaz depuis un voisin. Suivez les instructions du fournisseur.
- Si vous ne pouvez rejoindre le fournisseur de gaz, appelez le service des incendies.

L'installation et l'entretien doivent être assurés par un installateur ou un service d'entretien qualifié ou par le fournisseur de gaz.

# Brute MagnaTech HTD

## Contents

- 1. Shutting down the MagnaTech ..... 2
- 2. Restarting the MagnaTech ..... 2
- 3. Start-Up and Shut-Down Decal ..... 3
- 4. In the Event of Power Failure ..... 5
- 5. General Care ..... 5
- 6. Annual Inspection and Service ..... 5
- 7. For Service ..... 5
- 8. About Lockouts, Holds and Alerts ..... 5
- 9. Touchscreen Display ..... 6

For full instructions regarding the MagnaTech HTD, please reference the MagnaTech “Installation and Operation Manual”, Document #1422. If not available at or near the MagnaTech, it can be downloaded at [www.bradfordwhite.com](http://www.bradfordwhite.com)



## 2. Shutting down the MagnaTech

It may sometimes be necessary to shut down the MagnaTech. Here are the steps required to do this:

- 1. Disconnect Power at the main electrical disconnect switch.
- 2. Shut the main manual gas valve located at the back of the unit. It has a yellow handle
- 3. If freezing is anticipated, drain the MagnaTech (also be sure to protect the piping in the building from freezing.)

The steps listed above may require qualified service personnel.

## 1. Restarting the MagnaTech

It may be necessary to restart the MagnaTech – for example, after a power interruption. Here are the steps required to do this:

Example

**Lockout: Outlet Probe High Limit**

**RESET**

- 1. Reset any errors. See Section 12 “Troubleshooting” of the Installation and Operating Manual.
- 2. Turn up the thermostat to call for heat.
- 3. In approximately 2 seconds, the blower will operate. Ignition should occur after 35-40 seconds. It may take as long as 2-1/2 minutes.
- 4. If ignition does not occur, wait 5 minutes and then repeat steps 1 through 3.
- 5. If, after three attempts, the unit still does not light, shut down the unit and call your service technician.

### 3. Start-Up and Shut-Down Decal. Located inside the front panel.

#### FOR YOUR SAFETY READ BEFORE OPERATING



**WARNING:** If you do not follow these instructions exactly, a fire or explosion may result causing property damage, personal injury or loss of life.

- A. This appliance is equipped with an ignition device which automatically lights the pilot. Do not try to light the pilot by hand.
- B. BEFORE OPERATING, smell all around the appliance area for gas. Be sure to smell next to the floor because some gas is heavier than air and will settle on the floor.

#### WHAT TO DO IF YOU SMELL GAS

- Do not try to light any appliance.
  - Do not touch any electric switch; do not use any phone in your building.
  - Immediately call your gas supplier from a neighbor's phone. Follow the gas supplier's instructions.
  - If you cannot reach your gas supplier, call the fire department.
- C. Use only your hand to turn the gas valve handle. Never use tools. If the valve handle will not turn by hand, don't try to repair it, call a qualified service technician. Force or attempted repair may result in a fire or explosion.
  - D. Do not use this appliance if any part has been under water. Immediately call a qualified service technician to inspect the appliance and to replace any part of the control system and any gas control which has been under water.

#### OPERATING INSTRUCTIONS

1. STOP! Read the safety information above on this label.
2. Turn off all electric power to the appliance.
3. Set the thermostat to lowest setting.
4. This appliance is equipped with an ignition device which automatically lights the pilot. Do not try to light the pilot by hand.
5. Open front doors.
6. Turn off manual gas valve. Valve is off when valve handle is at a right angle to gas pipe.
7. Wait five (5) minutes to clear out any gas. Then smell for gas, including near the floor. If you do smell gas, STOP! Follow "B" in the safety information above on this label. If you don't smell gas, go to next step.
8. Slowly turn manual gas valve to "ON". Valve handle will be parallel to gas pipe.
9. Replace front panel.
10. Set mechanical thermostats to desired settings.
11. Turn on all electric power to the appliance.
12. Set operating thermostat to desired settings using boiler display.
13. If the appliance will not operate, follow the instructions "To Turn Off Gas To Appliance" and call your service technician or gas supplier.

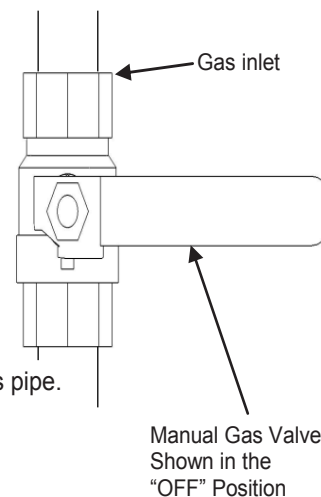

#### TO TURN OFF GAS TO APPLIANCE

1. Turn off all electric power to the appliance if service is to be performed.
2. Open front doors.
3. Set the thermostat to lowest setting.
4. Turn off manual gas valve. Valve is off when valve handle is at a right angle to gas pipe.
5. Close front doors.

**POUR VOTRE SÉCURITÉ, LISEZ AVANT DE METTRE EN MARCHÉ**

Continues on next page.

## Start up and Shut Down Decal (continued)

**POUR VOTRE SÉCURITÉ, LISEZ AVANT DE METTRE EN MARCHÉ**

**⚠ AVERTISSEMENT: Quiconque ne respecte pas à la lettre les instructions dans la présente notice risque un début d'incendie ou une explosion entraînant des dommages, des blessures ou la mort.**

- A. Cet appareil est équipé d'un dispositif d'allumage qui s'allume automatiquement le pilote. N'essayez pas de lumière le pilote à la main.
- B. AVANT DE FAIRE FONCTIONNER, reniflez tout autour de l'appareil pour déceler une odeur de gaz. Reniflez près du plancher, car certains gaz sont plus lourds que l'air et peuvent s'accumuler au niveau du sol.

**QUE FAIRE SI VOUS SENTEZ UNE ODEUR DE GAZ**

- Ne pas tenter d'allumer d'appareil.
  - Ne toucher à aucun interrupteur; ne pas vous servir des téléphones se trouvant dans le bâtiment.
  - Appelez immédiatement votre fournisseur de gaz depuis un voisin. Suivez les instructions du fournisseur.
  - Si vous ne pouvez rejoindre le fournisseur, appelez le service des incendies.
- C. N'utilisez que votre main pour fermer la soupape d'arrêt de gaz. N'utilisez jamais d'outils. Si la poignée de la valve ne tourne pas manuellement, ne tentez pas de la réparer. Communiquez avec un technicien de service qualifié. Le fait de forcer ou de tenter de réparer la poignée pourrait causer un incendie ou une explosion.
  - D. N'utilisez pas cet appareil s'il a été plongé dans l'eau, même partiellement. Faites inspecter l'appareil par un technicien qualifié et remplacez toute partie du système de contrôle et toute commande qui ont été plongées dans l'eau.

**INSTRUCTIONS DE MISE EN MARCHÉ**

1. ARRÊTEZ ! Lisez les instructions de sécurité sur la portion supérieure.
2. Coupez l'alimentation électrique de l'appareil.
3. Réglez le thermostat à la température la plus basse.
4. Cet appareil est équipé d'un dispositif d'allumage qui s'allume automatiquement le pilote. N'essayez pas de lumière le pilote à la main.
5. Ouvrir les portes avant.
6. Mettez la soupape d'arrêt de gaz à << OFF >>. La valve est en position << OFF >> lorsque la poignée se trouve à angle droit du tuyau de gaz.
7. Attendez cinq (5) minutes afin que le gaz se dissipe. Si vous croyez sentir une odeur de gaz, ARRÊTEZ ! Reportez-vous aux instructions B ci-dessus, sur cette étiquette. S'il n'y a pas d'odeur de gaz, passez à la prochaine étape.
8. Remettez lentement la soupape d'arrêt de gaz en position << ON >>. La poignée sera parallèle au tuyau de gaz.
9. Remplacez le couvercle avant.
10. Set thermostats mécaniques sur les réglages désirés.
11. Rétablissez l'alimentation électrique à l'appareil.
12. Réglez le thermostat de fonctionnement désirée à l'aide paramètres affichage chaudière.
13. Si l'appareil ne fonctionne pas, suivez les directives relatives à la fermeture de l'alimentation en gaz et communiquez avec votre technicien de service ou le fournisseur de gaz.

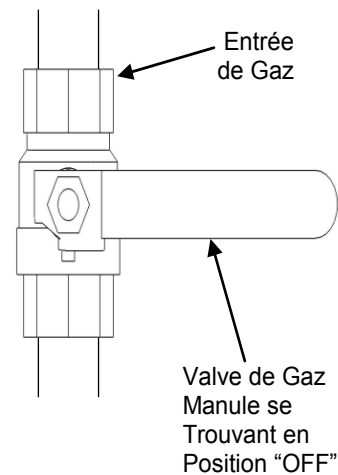
**FERMENTURE DE L'ALIMENTATION EN GAZ**

1. Coupez toute alimentation électrique à l'appareil si celui-ci doit faire l'objet d'un entretien.
2. Ouvrir les portes avant.
3. Réglez le thermostat au réglage le plus bas.
4. Mettez la soupape d'arrêt de gaz à << OFF >>. La valve est en position << OFF >> lorsque la poignée se trouve à angle droit du tuyau de gaz.
5. Fermez les portes avant.

H2363600A

#### 4. In the Event of Power Failure

The MagnaTech will not operate during an electrical power outage. If there is an extended power outage with danger of freezing, then the MagnaTech (and all other water systems) should be completely drained. Before draining the unit, turn off the gas and turn off the main power switch. When you replace the unit in service, refer to the "Installation and Operation Manual" for instructions on filling and purging.

#### 5. General Care

Keep the area around the MagnaTech clear and free from combustible materials, gasoline and other flammable vapors and liquids. Clean the jacket surfaces with a damp cloth and mild soap. Do not use flammable cleaning materials. Keep the vent terminal free of obstructions. Do not pile snow against the vent terminal.

#### 6. Annual Inspection and Service

You should visually inspect the vent pipe once a year. Should any corrosion or leaks exist, have the affected parts replaced.

Once each year a qualified service agency should conduct a detailed inspection of all flue product carrying areas of the boiler and vent system. Follow the service instructions in the "Installation and Operating Instructions Manual" for the MagnaTech.

Once each year inspect the condensate drain line, vent line, condensate PVC fittings, the condensate trap and condensate neutralizer (if installed). If necessary, disassemble and flush with fresh water and reassemble.

Once each year inspect and clean the air inlet filter. See the Section 11 of your units Installation and Operation Instructions for a complete list of maintenance items.

#### 7. For Service

Contact your installing contractor, gas utility, Bradford white dealer, or check [www.BradfordWhite.com](http://www.BradfordWhite.com) for the nearest authorized representative in your area.

#### 8. About Lockouts, Limits and Alarms

The system responds to three kinds of trouble indications:

A **Lockout** is caused by a serious problem that might involve a safety issue. Once the controller enters a lockout, the burners will shut down, and will not be allowed to run again until the cause of the problem is corrected, and you reset the control system. If the lock-out does not reset, or the lock-out condition continues to occur, contact a qualified service agency to restore the unit to normal operations. See the Installation and Operation Instructions for the full list of lockouts.

There are also **Limits** which will cause the boiler to shut down but allow restart when the fault goes away or the limit value is no longer exceeded. In this case, operator intervention is not required. An example of this is a water flow switch safety limit. If the water flow to the boiler drops below a pre-set value, the unit will shut down but restart when the correct flow rate is re-established. In some cases, if the fault continues to occur, the system will enter a Lockout condition.

**Alarm** conditions are indicated through lockout banners and/or messages. Lockout conditions are annunciated with a red banner at the top of the display and a corresponding code. The message icon will show an exclamation point when there is a message. Messages will provide information regarding the status of the unit and the condition limiting operation.

## 9. Touchscreen Display

See the Installation and Operating Manual (Doc 1422) full details on all Touchscreen Control Menus.

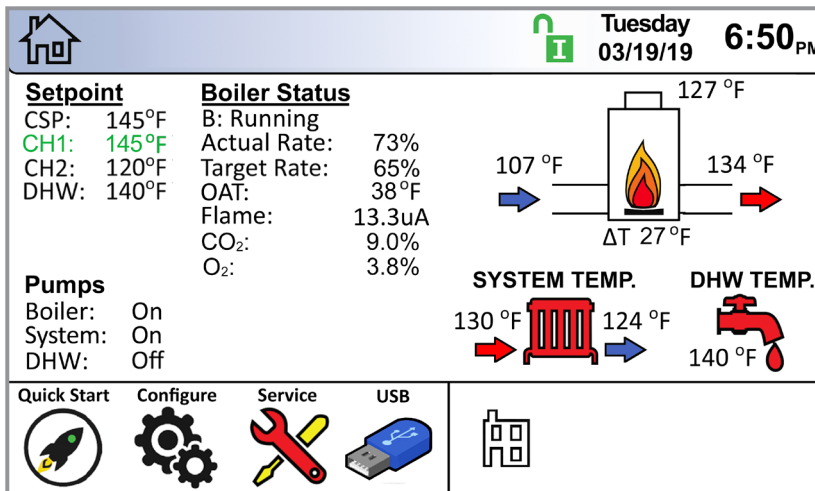

### Home Screen Active Icons

Name	Icon	Description
Security		Displays the current lock status icon. Touch the lock icon to lock or unlock the Touchscreen Display.
Quick Start		Provides quick access to the most commonly used parameters for easy installation.
Configure		Provides access to ALL of your configurations for a detailed setup of the unit.
Service		Allows the service technician to access the basic diagnostic and troubleshooting information.
Messages		Will show an 'Exclamation Point' when there is a message. Clicking onto the Message icon will take you to the message itself. The USB functionality will show the USB Icon at this location, if being used.
Active Demands		Will show icons that indicate the active parameters that are currently in demand.
Navigation Bar		Top left of every menu. The constant indicator of where you are as you navigate into and out of the touchscreens.  <b>ERROR</b> Codes and <b>LOCKOUTS</b> also show in the <i>Navigation Bar</i> when there is one of several unit errors or shut-downs that have occurred.  <b>Lockout: Outlet Probe High Limit</b> <span style="border: 1px solid black; padding: 2px 10px;">RESET</span>
Date & Time	Thursday 03/19/17 5:12 PM	To change date and time, simply touch the date or time and follow the directions.

Please refer to the Installation and Operating Manual (Doc 1440) for full details regarding operating the touchscreen display.

### Typical Numeric Keypad Menu

NOTE: You can always tell exactly where you have navigated to by looking at the icons in the *Navigation Bar*.

In this example you are in **Home / Configure / Central Heat / Central Heat One**

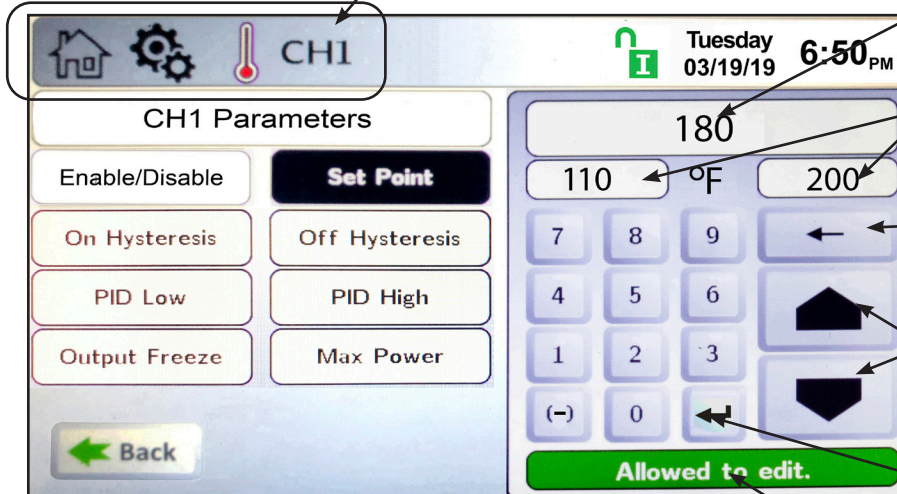

Shows the current setting of the Parameter.

These windows will reflect the allowable ranges of the parameter

To delete the current setting before entering in the new value.

“Up and Down” arrows are used to increment the setting accordingly.

The “Enter” button is used to accept the new value.

This is the indicator that will be shown when the correct password has been entered to allow the setting to change.

Remember to always save the new setting with the  button.

### Typical Selection Screen

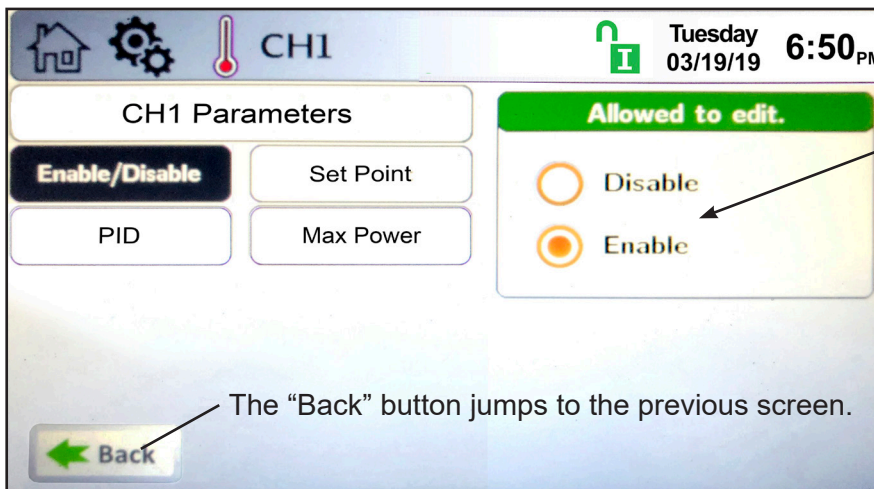

The highlighted button (orange) shows which one is selected. Some screens may only allow you to set one or the other, while some other screens (example: pump selection) will allow you to select any or all of the options.

The “Back” button jumps to the previous screen.

**⚠ WARNING**

**Carbon Monoxide Hazard**

This product burns gas to produce heat. The appliance must be properly installed, operated, and maintained to avoid exposure to appreciable levels of carbon monoxide and the installer is required to confirm that at least one carbon monoxide alarm is installed in the living space before the appliance is put into operation.

It is important for carbon monoxide alarms to be installed, maintained, and replaced following the alarm manufacturer's instructions and applicable local codes.

**⚠ AVERTISSEMENT**

**Danger lié au monoxyde de carbone**

Ce produit brûle des gaz pour produire de la chaleur. L'appareil requiert une installation, un fonctionnement et une maintenance adéquates afin d'éviter l'exposition à des niveaux appréciables de monoxyde de carbone; l'installateur est requis de confirmer qu'au moins une alarme de détection de monoxyde de carbone est installée dans l'espace de vie avant que l'appareil ne soit mis en service.

Il importe que les alarmes de détection de monoxyde de carbone soient installées, maintenues et remplacées selon les directives du manufacturier et les codes locaux applicables.

**⚠ CAUTION**

Do not use this boiler if any part has been under water. Immediately call a qualified service technician to inspect the boiler. Any part of the control system and any gas control which has been under water must be replaced.

N'utilisez pas cette chaudière si une partie a été sous l'eau. Appelez immédiatement un technicien de service qualifié pour inspecter la chaudière. Toute partie du système de contrôle et toute commande qui ont été plongées dans l'eau doit être remplacé

**⚠ WARNING**

If the unit overheats or the gas supply fails to shut off, do not turn off or disconnect the electrical supply to the pump. Instead, shut off the gas supply at a location external to this unit.

En cas de surchauffe ou si l'admission de gaz ne peut être coupée, ne pas couper ni débrancher l'alimentation électrique de la pompe. Fermer plutôt le robinet d'admission de gaz à l'extérieur de l'appareil.



H2403800A-



200 Lafayette St.  
 Middleville, MI 49333  
 Warranty: (800) 531-2111

[www.BradfordWhite.com](http://www.BradfordWhite.com)

Litho in U.S.A. © Bradford White 23-10 Document 1441A-BW