

# Brute®

# Volume Water Heater

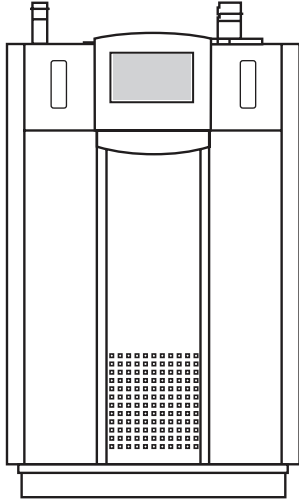

Date:

Project #:

Engineer:

Prepared By:

Bid Date:

BNTV | Volume Water Heater

*Indoor Sizes 285-850*

**Submittal Data**



Project Name:

Location:

Contractor:

## Standard Equipment

- Electronic PID modulating control with large color touchscreen display
- Password-protected parameters for installer use
- Test feature allows forced min or max firing
- Complete diagnostics for analog and digital inputs
- Displays holds, alerts and errors in clear text form
- Dry alarm contacts for ignition failure
- High condensing efficiency
- Modulation down to 20% of full fire (5:1 turndown)
- Sealed combustion chamber
- Pre-mix stainless steel burner
- Low NOx system
- Horizontal or vertical direct vent
- Horizontal vent and air terminals
- Vent and air pipe lengths of up to 100 equivalent feet (each)
- Built-in condensate trap
- Vent temperature cutoff feature
- Direct spark ignition system
- Sensor for domestic water tank
- 160 psi maximum working pressure
- Stainless steel heat exchanger with welded construction (no gaskets)
- ASME "H" stamp
- Meets NSF/ANSI-372 Low Lead Content Certification (BNTV)
- 125 psi (861 kPa) ASME rated pressure relief valve
- Water flow switch (399-850 only)
- Temperature & pressure gauge
- Drain valve
- Integrated PID temperature and ignition controls
- Alarm output
- Accepts external 4-20mA (0-10V with optional convertor) modulation signal
- On/off toggle switch
- Manual reset high limit
- Burner site glass
- Zero clearance to combustible surfaces
- Built-in cascade function for up to eight Brutes.
- 8 year limited warranty

## Heater Data

Number of Units:

Fuel

- Natural (285 only)
- Propane (all sizes)

- Pump included
- No pump

## Factory Mounted Options

- ASME "HLW" Stamp (285-850 only)
- CSD-1 (covers FM & GAP) (500-850 only)
- Low water cutoff (500-850 only)
- High & Low gas pressure switches (500-850)
- Additional auto reset high limit
- 60 psi pressure relief valve
- 75 psi pressure relief valve
- 125 psi pressure relief valve (std)
- 150 psi pressure relief valve
- Bell for ignition failure



## Accessories for Field Mounting

<input type="checkbox"/> Water flow switch (285 only)	<input type="checkbox"/> Boiler pump	<input type="checkbox"/> Propane conversion kit
<input type="checkbox"/> Low water cutoff	<input type="checkbox"/> Concentric vent terminal, 2"	<input type="checkbox"/> Condensate neutralizer kit
<input type="checkbox"/> 0 - 10V converter for modulation control	<input type="checkbox"/> Concentric vent terminal, 3"	<input type="checkbox"/> BACnet gateway
<input type="checkbox"/> High & Low gas pressure switches	<input type="checkbox"/> Flush-mount terminal, 3"	<input type="checkbox"/> LON gateway
	<input type="checkbox"/> Flush-mount terminal, 4"	<input type="checkbox"/> Common vent kit (285-500, one required for each unit)

## Sizing Data

Model	Input		Output		Gas Conn. Size inches	Water Conn. Size inches	Shipping Weight	
	BTU/h	kW	BTU/h	kW			lbs	kg
<input type="checkbox"/> BNTV 285	<b>285,000</b>	83.5	<b>270,750</b>	79.3	¾ NPT	2 NPT	<b>299</b>	136
<input type="checkbox"/> BNTV 399	<b>399,000</b>	116.9	<b>383,040</b>	112.2	¾ NPT	2 NPT	<b>364</b>	165
<input type="checkbox"/> BNTV 500	<b>500,000</b>	146.5	<b>480,000</b>	140.6	1 NPT	2 NPT	<b>419</b>	190
<input type="checkbox"/> BNTV 600	<b>600,000</b>	175.8	<b>582,000</b>	170.4	1 NPT	2 NPT	<b>426</b>	193
<input type="checkbox"/> BNTV 750	<b>750,000</b>	219.8	<b>705,000</b>	206.4	1½ NPT	2 NPT	<b>481</b>	218
<input type="checkbox"/> BNTV 850	<b>850,000</b>	249.1	<b>816,000</b>	238.9	1½ NPT	2 NPT	<b>503</b>	228

## Clearances

Appliance Surface	Suggested Service Access Clearance	
	inches	cm
Left Side	<b>1</b>	2.5
Right Side	<b>12</b>	31
Top	<b>24</b>	61
Back	<b>6</b>	15
Closet, Front	<b>1</b>	2.5
Alcove, Front	<b>24</b>	61
Vent	Per Vent Manufacturer	

Certified by CSA for zero clearance to combustibile materials on all sides.

## Vent System

Size	Intake (Air)	Exhaust (Vent)	Maximum Allowable	
	Pipe	Pipe	Equivalent Length*	
285	3"	3"	20 ft	6.1 m
	4"	4"	100 ft	30 m
399	4"	4"	100 ft	30 m
500	4"	4"	100 ft	30 m
600	4"	4"	40 ft	12 m
	6***	6***	100 ft	30 m
750	4"	4"	40 ft	12 m
	6"	6"	100 ft**	30 m**
850	4"	4"	40 ft	12 m
	6"	6"	100 ft	30 m

Installations in the U.S. require exhaust vent pipe that is a combination of PVC & CPVC complying with ANSI/ASTM D1785 F441, polypropylene pipe that complies with ULC S636, or stainless steel complying with UL1738. Installations in Canada require exhaust vent pipe that is certified to ULC S636.

Intake (air) pipe may be ABS, PVC, CPVC or galvanized material.

Installer must comply fully with manufacturer's installation instructions, including use of minimum exhaust length CPVC, to maintain ANSI Z21.13 safety certification.

Closet and alcove installations do not allow the use of PVC under any circumstances

\* To calculate max equivalent length, measure the linear feet of the pipe, and add 5 feet (1.5m) for each elbow used.

\*\* Allowed only if the vent pipe is no more than 20 equivalent feet longer than the air pipe.

## Electrical Data

Heater	Heater Circuit		Heater Pump Circuit	
	285-500	600-850	285-500	600-850
Size MBH	285-500	600-850	285-500	600-850
Voltage	120V 1PH	120V 1PH	120V 1PH	120V 1PH
FLA	< 4 Amps	5 Amps	6 Amps	12 Amps
MCA	< 4 Amps	6 Amps	8 Amps	15 Amps
MOP	5 Amps	11 Amps	14 Amps	27 Amps

FLA = Full Load Amperage

MCA = Minimum Circuit Ampacity

MOP = Maximum Over-current Protection

\* Note: For any pump(s) exceeding 7.4 FLA / 120V VAC, an external pump relay / contactor must be used. Units that are purchased with pumps include the contactor if the pump exceeds this limit.

## Recovery Data

Size	GPH Delivered								
	REQUIRED WATER TEMPERATURE RISE								
	40°F	50°F	60°F	70°F	80°F	90°F	100°F	120°F	140°F
	<b>GPH</b>	<b>GPH</b>	<b>GPH</b>	<b>GPH</b>	<b>GPH</b>	<b>GPH</b>	<b>GPH</b>	<b>GPH</b>	<b>GPH</b>
285	818	654	545	467	409	363	327	273	234
399	1153	923	769	659	577	513	461	384	329
500	1451	1161	967	829	726	645	580	484	415
600	1729	1383	1152	988	864	768	691	576	494
750	2170	1736	1447	1240	1085	964	868	723	620
850	2434	1947	1622	1391	1217	1082	973	811	695

Size	L/h Delivered								
	REQUIRED WATER TEMPERATURE RISE								
	22°C	28°C	33°C	39°C	44°C	50°C	56°C	67°C	78°C
	<b>L/h</b>	<b>L/h</b>	<b>L/h</b>	<b>L/h</b>	<b>L/h</b>	<b>L/h</b>	<b>L/h</b>	<b>L/h</b>	<b>L/h</b>
285	3091	2473	2061	1766	1545	1374	1236	1030	883
399	4359	3487	2906	2491	2181	1937	1744	1453	1245
500	5485	4388	3657	3134	2743	2438	2194	1828	1567
600	6536	5288	4355	3735	3266	2903	2612	2177	1867
750	8203	6562	5470	4687	4101	3644	3281	2733	2344
850	9201	7360	6131	5258	4600	4090	3678	3066	2627

## Water Flow Requirements

	Flow	H/L	Temp Rise
	gpm	feet	F
285	30	22	18
399	45	28	17
500	52	26	18
600	52	26	22
750	60	27	24
850	67	25	24

	Flow	H/L	Temp Rise
	lpm	m	C
285	113.6	6.7	10
399	170.3	8.5	9
500	196.8	7.9	10
600	196.8	7.9	12
750	227.1	8.2	13
850	253.6	7.6	13

### Notes:

1. Pumps that are shipped with heaters are sized for 30 feet of full-sized piping and a typical number of fittings, intended to serve a heater with a tank that is within 15 feet.

2. Maximum water hardness of 10 grains per gallon allowed."

**Dimensional  
Data, Sizes  
285-500**

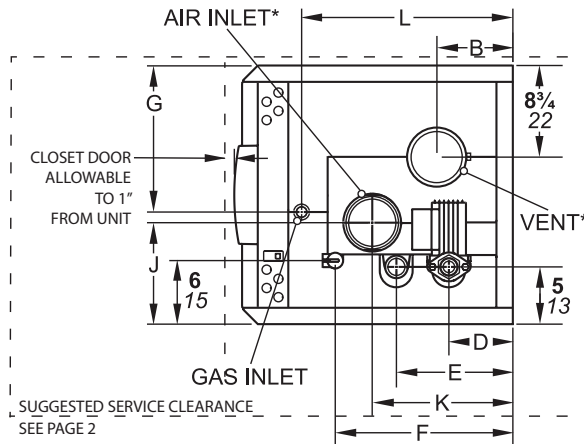

\*This unit is shipped with adapters for the air and vent that accept standard pipe of the proper size and type.

Dimensions shown in inches  
cm.

**TOP VIEW**

Optional Pump Location  
(field-mounted)

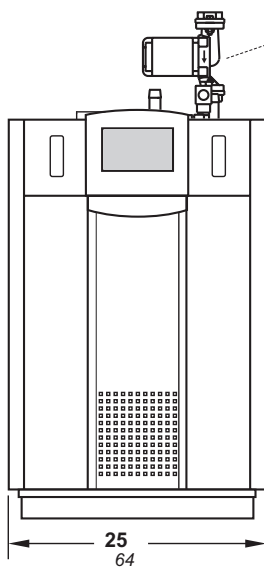

**FRONT VIEW**

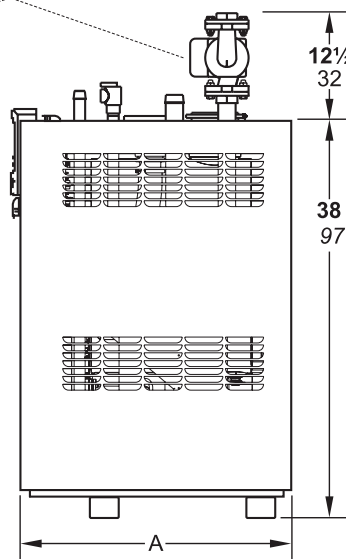

**RIGHT SIDE VIEW**

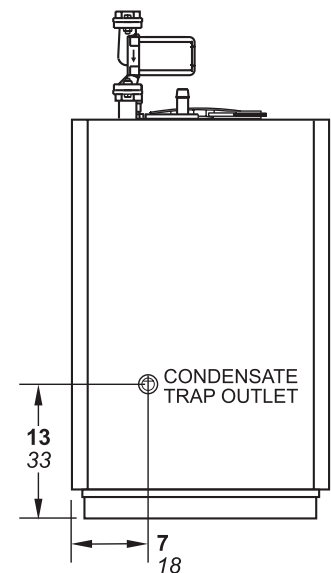

**BACK VIEW**

BNTV Size	A in	B in	D in	E in	F in	G in	J in	K in	L in	Ø AIR INLET* in	Ø VENT* in
285	26 3/4	7 1/4	6 1/4	11	17	14	9 3/4	13 1/4	20 1/4	4	4
399	31 1/2	5 1/4	4 1/4	14 1/2	21 1/2	19 1/4	8 1/4	18 1/2	25	4	4
500	37 3/4	5 1/4	4 1/4	15	26	20 1/2	5 3/4	20	27 1/4	4	4
	cm	cm	cm	cm	cm	cm	cm	cm	cm	cm	cm
285	68	18	15	28	43	36	25	34	51	11	11
399	80	13	11	37	55	49	21	47	64	11	11
500	96	13	11	38	66	52	15	51	69	11	11

Dimensions are nominal.

**Dimensional  
Data, Sizes  
600-850**

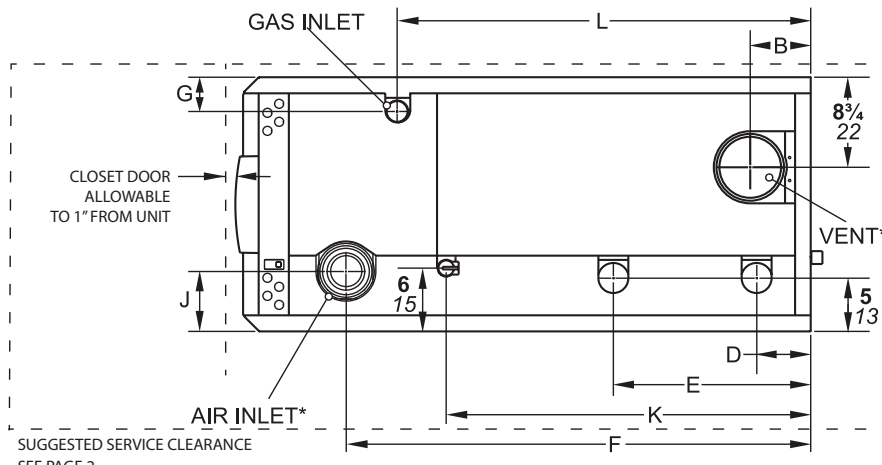

**TOP VIEW**

\*This unit is shipped with adapters for the air and vent that accept standard pipe of the proper size and type.

Dimensions shown in **inches**  
*cm.*

Optional pump is shipped loose and is not shown.  
Optional Pump is mounted in the field.

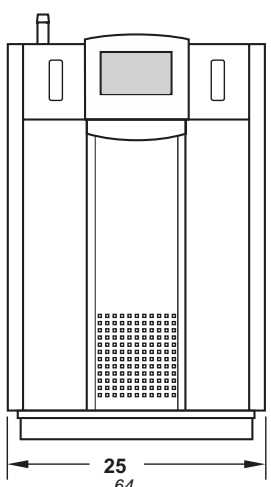

**FRONT VIEW**

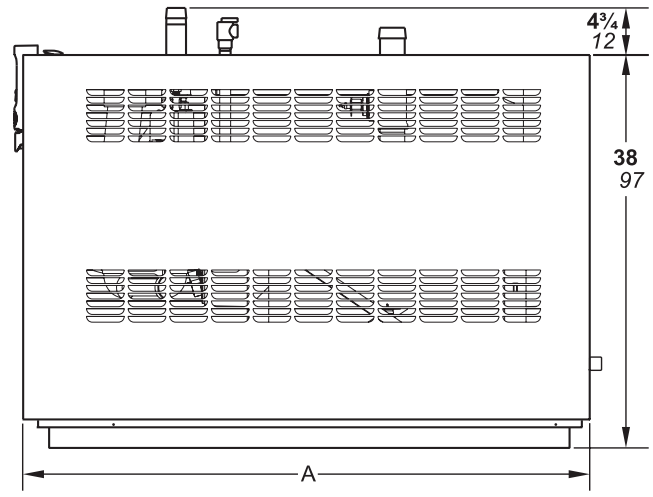

**RIGHT SIDE VIEW**

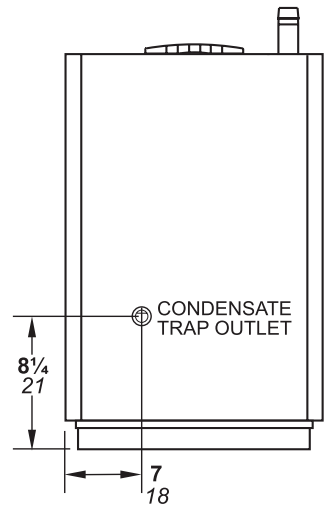

**BACK VIEW**

BNTV	A	B	D	E	F	G	J	K	L	AIR Ø INLET*	Ø VENT*
Size	in	in	in	in	in	in	in	in	in	in	in
600	37 <sup>3</sup> / <sub>4</sub>	5	4 <sup>1</sup> / <sub>4</sub>	15	20	3	5 <sup>3</sup> / <sub>4</sub>	26	29 <sup>3</sup> / <sub>4</sub>	4	4
750	51	6	5 <sup>1</sup> / <sub>4</sub>	19	40 <sup>1</sup> / <sub>2</sub>	3 <sup>1</sup> / <sub>4</sub>	5 <sup>3</sup> / <sub>4</sub>	30 <sup>1</sup> / <sub>2</sub>	35 <sup>1</sup> / <sub>2</sub>	4	6
850	55 <sup>1</sup> / <sub>4</sub>	6	5 <sup>1</sup> / <sub>4</sub>	19	44 <sup>1</sup> / <sub>2</sub>	3 <sup>1</sup> / <sub>2</sub>	5 <sup>3</sup> / <sub>4</sub>	35	39 <sup>3</sup> / <sub>4</sub>	4	6
	<i>cm</i>	<i>cm</i>	<i>cm</i>	<i>cm</i>	<i>cm</i>	<i>cm</i>	<i>cm</i>	<i>cm</i>	<i>cm</i>	<i>cc</i>	<i>cm</i>
600	96	13	11	38	51	8	15	66	76	11	11
750	130	13	13	48	103	8	15	77	90	11	17
850	140	13	13	48	113	9	15	89	101	11	17

Dimensions are nominal.





