

Combi™

Residential Atmospheric Vent Combi™ Energy Saver Gas Water Heater System



Photo is of
C-SW2-504T10FBN

The Combi™ FVIR Defender Safety System® Models Feature:

- **Advanced ScreenLok® Technology Flame Arrestor Design**—Flame arrestor is designed to prevent ignition of flammable vapor outside of the water heater.
- **Resettable Thermal Switch**—Proven and reliable bimetallic switch prevents burner and pilot operation in case of ongoing flammable vapor burn inside of the combustion chamber or restricted air flow.
- **Pedestal Base**—Rugged and durable base allows easy transport and positioning, and provides corrosion resistant contact with floor.
- **Maintenance Free**—Regular cleaning of air inlet openings or flame arrestor is not required under normal conditions.
- **Sight Window**—Offers a view into the combustion chamber to observe the operation of the pilot and burner.
- **Piezo Igniter**—Easy and quick lighting of the pilot burner by push button.
- **Heat Exchanger**—Single Wall 1½" O.D. glass coated (Vitraglas®) carbon steel coil.
- **Low Heat Exchanger Head Loss**—Up to 10 GPM flow, with less than 5 ft. of head loss. Greatly reduces the required pump size for heat exchange.
- **Factory Installed Hydrojet® Total Performance System**—Cold water inlet sediment reducing device helps prevent sediment build up in tank. Increases first hour delivery of hot water while minimizing temperature build up.
- **Supply and Return Connections**—The 1" NPT female connections are located on the front for both the space heating supply and return.
- **Vitraglas® Lining**—Bradford White water heater tanks are protected from the corrosive effects of hot water by an exclusive ceramic porcelain-like coating. The Bradford White high silica Vitraglas® lining provides a tough interior surface for our hot water tanks.
- **Optimizer™ Temperature Control System**—Integrated mixing device features a thermostatically controlled mixing device that is pre-piped with a flexible connector. This required system ensures a comfortable outlet temperature while providing a steady flow of hot water.
- **Fully Automatic Controls**—Built-in energy cut-off switch prevents abnormally high water temperature for extra safety. Built-in gas pressure regulation.
- **2" Non-CFC Foam Insulation**—Covers the sides and top of tank, reducing the amount of heat loss. This results in less energy consumption, improved operation efficiencies and jacket rigidity.
- **Water Connections**—¾" NPT factory installed true dielectric fittings extend water heater life and eases installation.
- **Two Protective Aluminum Anode Rods**—Provide added protection against corrosion for long trouble-free service.
- **Steel Tank**—Heavy gauge steel automatically formed, rolled and welded.
- **T&P Relief Valve**—Installed.
- **Brass Drain Valve.**
- **Design Certified by CSA International (formerly AGA/CGA).**



10-Year Limited Tank and Heat Exchanger Warranties / 6-Year Limited Warranty on Component Parts.

For more information on warranty, please visit www.bradfordwhite.com

For products installed in USA, Canada and Puerto Rico. Some states do not allow limitations on warranties. See complete copy of the warranty included with the heater.

MANUFACTURED UNDER ONE OR MORE OF THE FOLLOWING U.S. PATENTS: 5,954,492; 5,761,379; 5,943,984; 5,081,696; 5,988,117; 6,142,216; 5,199,385; 5,574,822; 5,372,185; 5,485,879; 5,277,171; (B1)5,341,770; 5,660,165; 5,596,952; 5,682,666; 4,904,428; 5,023,031; 5,000,893; 4,669,448; 4,829,983; 4,808,356; 5,115,767; 5,092,519; 5,052,346; 4,416,222; 4,628,184; 4,861,968; 4,672,919; Re. 34,534; 7,270,087 B2. OTHER U.S. AND FOREIGN PATENT APPLICATIONS PENDING. CURRENT CANADIAN PATENTS: 1,272,914; 1,280,043; 1,289,832; 2,045,862; 2,112,515; 2,108,186; 2,107,012; 2,092,105; 2,409,271
Vitraglas®, Hydrojet®, Defender Safety System® and ScreenLok® are registered trademarks of Bradford White® Corporation.

Residential Atmospheric Vent Gas Water Heater System



Combi1™ Energy Saver Models

NATURAL GAS AND LIQUID PROPANE GAS

Meet or exceed ASHRAE 90.1b (current standard) C.E.C. Listed
80% Recovery Efficiency

Model Number	Capacity		LP BTU/Hr. Input	Recovery 90°F Rise*				A Floor to Flue Conn. in.	B Jacket Dia. in.	C Vent Size in.	D Floor to T&P Conn. in.	E Floor to Gas Conn. in.	F Floor to Exchanger Inlet in.	G Floor to Exchanger Outlet in.	H Floor to Top of Heater in.	J Floor to Water Conn. in.	K Depth in.	Approx. Shipping Weight lbs.	
	U.S. Gal.	Imp. Gal.		Nat. BTU/Hr. Input	Nat. U.S. GPH	Nat. Imp. GPH	LP U.S. GPH												LP Imp. GPH
C-SW2-504T10FBN	45	38	65,000	61,000	70	59	66	55	59%	22	4	50	13	31½	50	56%	60%	24%	236

Model Number	Capacity		LP kW Input	Recovery 50°C Rise*				A Floor to Flue Conn. mm.	B Jacket Dia. mm.	C Vent Size mm.	D Floor to T&P Conn. mm.	E Floor to Gas Conn. mm.	F Floor to Exchanger Inlet mm.	G Floor to Exchanger Outlet mm.	H Floor to Top of Heater mm.	J Floor to Water Conn. mm.	K Depth mm.	Approx. Shipping Weight kg.
	Liters	Imp. Gal.		Nat. kW Input	Nat. Liters/Hour	Nat. Imp. Liters/Hour	LP Liters/Hour											
C-SW2-504T10FBN	170	19.1	17.9	265	250	1505	559	102	1270	330	800	1270	1432	1534	622	107		

Propane model features a Titanium Stainless Steel propane burner. For propane (LP) models change suffix "BN" to "SX".

*Based on manufacturers rated recovery efficiency.

CAEF is .55 and CAAFE% is 80.0.

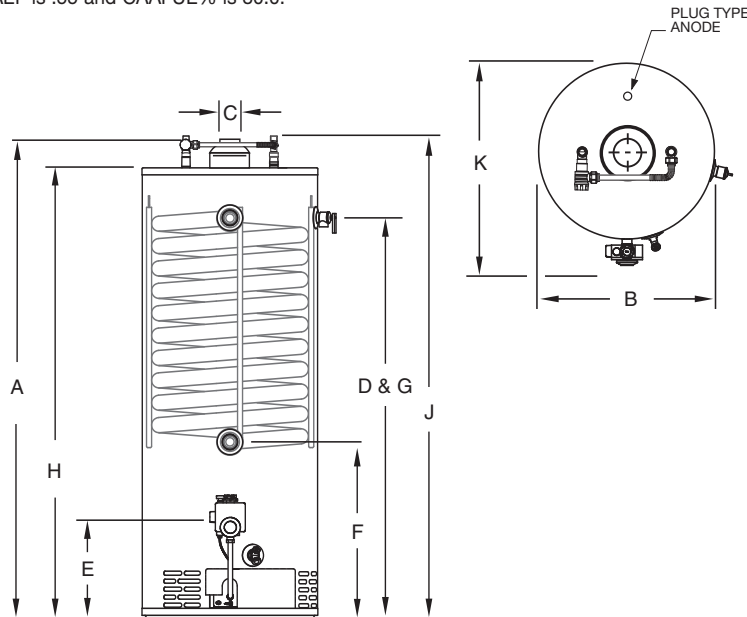

Heat Exchanger Head Loss	
GPM	Ft. of Hd. Loss
2	0.03
5	0.20
8	0.51
10	0.80
12	1.15

Heat Exchanger Values*

Supply Temperature	140°F	120°F	100°F
Return Temperature	120°F	100°F	80°F
Differential	20°F	20°F	20°F
Flow Rate	4.1 GPM	4.6 GPM	4.6 GPM
Net Output	35,500 BTU/Hr.	39,500 BTU/Hr.	39,500 BTU/Hr.

*These values were obtained using 180°F stored tank temperature.

Net Output is the space heating capacity based on normal piping and pickup allowance of 15%.

Actual values may vary based on circulator flow rate, number of zones, water and space heating demands. Numbers subject to change.

Meets NAECA Requirements

General

All gas water heaters are certified at 300 PSI test pressure (2068 kPa) and 150 PSI working pressure (1034 kPa). All potable water connections are 3/4" NPT (19mm) on 11" (203mm) centers. All heat exchanger connections are 1" NPT (25mm). All gas connections 1/2" (13mm).

All models design certified by CSA International (formerly AGA/CGA), ANSI Z-21.10.1 and peak performance rated.

Dimensions and specifications subject to change without notice in accordance with our policy of continuous product improvement.

Suitable for Water (Potable) Heating and Space Heating.

Toxic chemicals, such as those used for boiler treatment, shall NEVER be introduced into the potable water side. The potable side of this unit may NEVER be connected to any existing heating system or component(s) previously used with a non-potable water heating appliance. The heat exchanger side of the unit may be used in space heating applications.



Ambler, PA

For U.S. and Canada field service, contact your professional installer or local Bradford White sales representative.

Sales 800-523-2931 • Fax 215-641-1670 / Technical Support 800-334-3393 • Fax 269-795-1089 • Warranty 800-531-2111 • Fax 269-795-1089

International: Telephone 215-641-9400 • Telefax 215-641-9750 / www.bradfordwhite.com

BRADFORD WHITE-CANADA INC. Sales / Technical Support 866-690-0961 / 905-238-0100 • Fax 905-238-0105 / www.bradfordwhite.com

Built to be the Best™

©2008, Bradford White Corporation. All rights reserved.