

Light-Duty Atmospheric Vent Commercial Gas Water Heater

Features

- **Defender Safety System®**—Designed to be the safest & most reliable flammable vapor ignition resistant system in the industry with a proven track record since 2003. Featuring an advanced ScreenLok® technology flame arrestor design, resettable thermal switch, sight window, and designed to be maintenance-free (LG250H653N only).
- **Bradford White ICON System®**—Intelligent gas control with no need for external electricity. Proprietary algorithms provide tighter temperature differential and consistent water temperature levels up to 180°F (82°C). LED light indicates operation status/service required.
- **Vitraglas® Lining with Microban®**—An exclusively engineered enamel formula that provides superior tank protection from the corrosive effects of water; and with Microban® antimicrobial product protection to help prevent the growth of bacteria, mold and mildew on the surface of the tank lining.
- **Hydrojet® Total Performance System**—Sediment reducing device that also increases first hour rating of hot water while minimizing temperature build-up in tank.

Additional Details

- **Side Connections**—Tappings that allow easy connections for space heating applications (potable water only).
- **Insulation System**—Non-CFC foam covers the sides and top of the tank, reducing heat loss. This results in less energy consumption, improved efficiencies, and jacket rigidity.
- **Pedestal Base**—Rugged and durable base allows easy transport and positioning while providing corrosion-resistant contact with floor (except LG2100H803N).
- **Water Connections**—NPT factory-installed dielectric waterway with heat traps.
- **Hand Hole Cleanout**—Allows inspection of tank interior and facilitates the removal of sediment deposits (LG2100H803N models only).
- **Protective Anode Rod.**
- **4" (107mm) "Snap Lock" Draft Diverter.**
- **T&P Relief Valve**—Installed.
- **Low Restrictive Brass Drain Valve**—Durable tamper proof design.
- **Thermostatic Mixing Valve (ASSE Approved)**—Included with LG255H783N only.
- **NOx Emissions**—Less than 40 ng/J.



Photo is of LG2100H803N

Bradford White
DEFENDER
Safety System

BRADFORD WHITE
ICON
System

VITRAGLAS
SUPERIOR PROTECTION SINCE 1981

+
MICROBAN
Hydrojet



3 or 5-Year Limited Tank Warranties / 1-Year Limited Warranty on Component Parts.

For more information on warranty, please visit www.bradfordwhite.com

For products installed in USA, Canada, and Puerto Rico. See complete copy of the warranty included with the heater for limitations.

Microban® antimicrobial product protection helps prevent the growth of bacteria, mold and mildew that may affect the product. The built-in antimicrobial properties do not protect users or others from disease-causing organisms. Microban® is a registered trademark of Microban Products Company.

Light-Duty Atmospheric Vent Commercial Gas Water Heater

SPECIFICATIONS

Natural Gas and Liquid Propane Gas

These water heaters meet or exceed all or portions of (where applicable) the minimum efficiency requirements of ASHRAE Standard 90.1 (latest edition).

Model Number	Rated Nominal Volume		DOE Rated Storage Volume Gal.	BTU/Hr. Input	LP BTU/Hr. Input	First Hour Rating Gal.	Uniform Energy Factor	Recovery at 100°F Rise*				Model Number	Rated Nominal Volume Liters	DOE Rated Storage Volume Liters	kW Input	LP kW Input	First Hour Rating Liters	Uniform Energy Factor	Recovery at 56°C Rise*	
	U.S. Gal.	Imp. Gal.						U.S. GPH	Imp. GPH	U.S. GPH	LP GPH								U.S. GPH	Imp. GPH
LG250H653N	48	40	46	65,000	61,000	106	0.63	63	53	63	53	LG250H653N	182	174	19.0	17.9	401	0.63	238	238
LG255H783N	55	46	55	78,000	78,000	115	0.61	76	63	76	63	LG255H783N	208	208	22.9	22.9	435	0.61	288	288
LG275H763N	75	63	72	76,000	76,000	135	0.59	74	62	74	62	LG275H763N	284	273	22.3	22.3	512	0.59	280	280
LG2100H803N	100	83	95	80,000	80,000	157	0.57	78	65	78	65	LG2100H803N	379	360	23.4	23.4	595	0.57	295	295

Model Number	A Floor to Flue Conn. in.	B Jacket Dia. in.	C Vent Size in.	D Floor to T&P Conn. in.	E Floor to Gas Conn. in.	F Floor to Top of Heater in.	G Floor to Water Conn. in.	H Depth in.	J C/L of Water Conn. in.	K Floor to Space Heating Inlet in.	L Floor to Space Heating Outlet in.	M Water Conn. NPT in.	R Space Heating Conn. Size in.	S Gas Conn. Size in.	Approx. Shipping Weight lbs.
LG250H653N	60 1/2	22	4	49 13/16	13	56 5/8	58 7/8	25 1/2	11	13 1/2	49 15/16	3/4	3/4	1/2	193
LG255H783N	58 1/2	24	4	48 1/8	13 1/8	54 3/4	56 1/2	27 1/4	8	13 1/2	48 1/8	3/4	3/4	1/2	207
LG275H763N	62 5/8	26	4	51 7/8	15	59 5/8	60 1/16	29 1/4	11	16 5/8	51 7/8	1	1	1/2	240
LG2100H803N	72 5/16	28 1/4	4	57 3/8	13	63 3/8	66 5/8	31 13/16	16	17 11/16	50 5/8	1 1/4	1 1/4	1/2	424

Model Number	A Floor to Flue Conn. mm.	B Jacket Dia. mm.	C Vent Size mm.	D Floor to T&P Conn. mm.	E Floor to Gas Conn. mm.	F Floor to Top of Heater mm.	G Floor to Water Conn. mm.	H Depth mm.	J C/L of Water Conn. mm.	K Floor to Space Heating Inlet mm.	L Floor to Space Heating Outlet mm.	M Water Conn. NPT mm.	R Space Heating Conn. Size mm.	M Water Conn. NPT mm.	Approx. Shipping Weight kg.
LG250H653N	1537	559	102	1265	330	1438	1495	648	279	343	1268	19	19	13	88
LG255H783N	1486	607	102	1222	333	1391	1435	692	203	343	1222	19	19	13	94
LG275H763N	1591	660	102	1318	381	1514	1526	700	279	422	1318	25	25	13	109
LG2100H803N	1837	718	102	1457	330	1610	1692	808	406	449	1286	32	32	13	192

Propane models feature a Titanium Stainless Steel propane burner. For Propane (LP) models change suffix "N" to "X". For 5 year models, change suffix "3" to "5".

* Based on manufacturer's rated recovery efficiency
 LG2100H803N model features hand hole cleanout.
 Uniform Energy Factor and First Hour Rating is based on the latest AHRI directory listings.
 NSF 5 Kits Available Except for LG2100H.

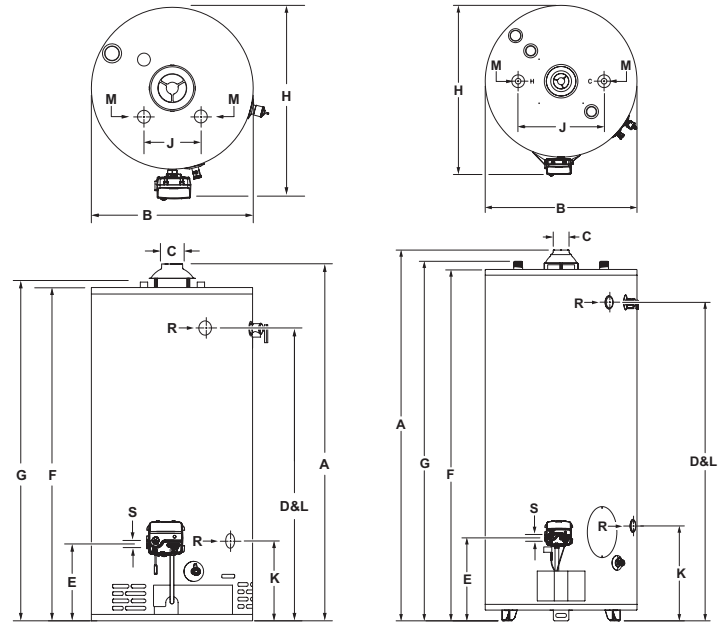

GENERAL:

Meets NAECA Requirements, as applicable.

All gas water heaters are certified at 300 PSI test pressure (2068 kPa) and 150 PSI working pressure (1034 kPa). All gas connections are 1/2" (13mm). All models design-certified by CSA International, ANSI standard Z21.10.3 and peak performance rated (LG250H653N = ANSI Z21.10.1).

Suitable for Water (Potable) Heating and Space Heating. Toxic chemicals, such as those used for boiler treatment, shall NEVER be introduced into this system. This unit may NEVER be connected to any existing heating system or component(s) previously used with a non-potable water heating appliance.

Dimensions and specifications subject to change without notice in accordance with our policy of continuous product improvement.



Sales: 800-523-2931

24/7 Technical Support: 800-334-3393 • Email: TechServ@bradfordwhite.com

Products made by Bradford White are manufactured in the United States using the finest raw materials and components from around the world. ©2026, Bradford White Corporation, USA. All rights reserved.

— BRADFORD WHITE IS —



1700-0226