



COMMERCIAL ELECTRIC WATER HEATERS



SERVICE MANUAL

**Troubleshooting Guide
and Instructions for Service**
(To be performed ONLY by qualified service providers)

**For Bradford White
Model Series:**

Light Duty:

SLE Upright Models.
LE Upright Models.
LE Utility Models. LE
Lowboy.
LE Wall Hung.



As required by the state of California Proposition 65.

Table of Contents

	<u>Page</u>	<u>Service Procedure</u>
Introduction.....	2	---
Tools.....	2	---
General Information.....	3	---
Sequence of Operation.....	6	---
Single Element Operation.....	6	---
Double Element Non-Simultaneous Single Phase.....	7	---
Double Element Simultaneous Single Phase 4 wire Service.....	8	---
Double Element Non-Simultaneous 3 Phase.....	9	---
Double Element Simultaneous 3 Phase.....	10	---
Double Element Non-Simultaneous Single Phase Off Peak	11	---
Troubleshooting.....	12	- - -
Line Voltage and High Limit ECO Testing.....	14	RE-I
Heating Element Testing.....	15	RE-II
Light Duty Commercial Thermostat Testing	16	RE III
Double Element, Non-Simultaneous, Single Phase.....	16	
Double Element, Simultaneous, Single Phase	18	
Double Element, Non-Simultaneous, 3 Phase	20	
Double Element, Simultaneous, 3 Phase	22	
Thermostat Removal and Replacement	24	RE-IV
Heating Element Removal and Replacement	25	RE-V
DipTube and Anode Inspection and Replacement	26	RE-VI
Generic Parts List	27	---

Introduction

This service manual is designed to aid service and maintenance professionals on the function, proper diagnosis and repair of Bradford White residential electric and light duty commercial electric water heaters.

The text and illustrations in this manual provide step by step instructions to facilitate proper operation and troubleshooting procedures. Contact the Bradford White Technical Support Group immediately if diagnosis can not be made using the methods described in this service manual.

Tools

- | | |
|------------------------|------------------------------|
| - Multi Meter | - Phillips Head Screw Driver |
| - 1-½ Deep Well Socket | - Thermometer |
| - ¼" Nut Driver | - Drain Hose |

- Various Hand Tools: Pipe Wrench, Channel Locks, Pliers (common & needle nose), Wire cutters, Wire Strippers, Flash Light.

Commonly Used Formulas

Amps = $\frac{\text{Watts}}{\text{Volts}}$ (for single phase units) Example: $4500\text{W}/240\text{V} = 18.75\text{A}$

Amps = $\frac{\text{Watts}}{\text{Volts} \times 1.732}$ (for balanced 3 phase units) Example: $4500\text{W}/240\text{V} \times 1.732 = 10.82\text{A}$

Watts = Amps x Volts Example: $18.75\text{A} \times 240\text{V} = 4500\text{W}$

Ohms = $\frac{\text{Volts}^2}{\text{Watts}}$ Example: $(240\text{V})^2 / 4500\text{W} = 12.8 \text{ Ohms}$

Common Service Wire Configurations

120 VOLT

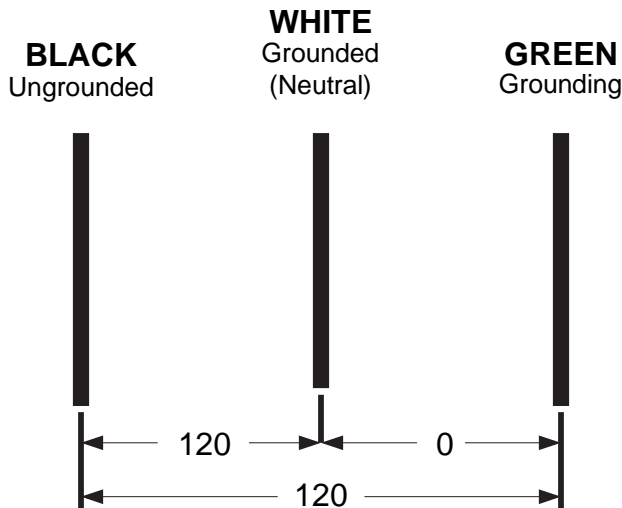

240 VOLT

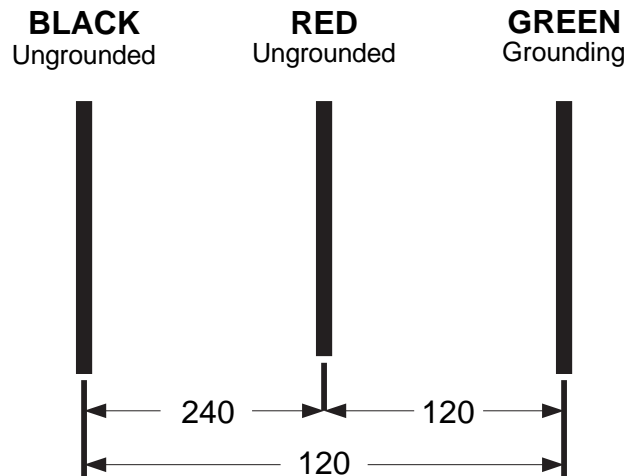

208 3Ph

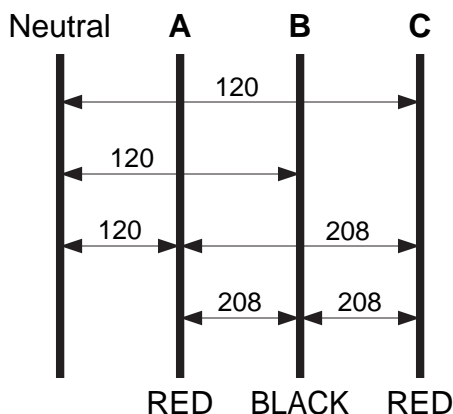

240 3Ph

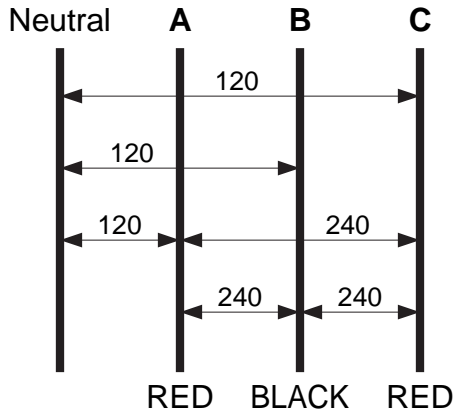

480 3Ph/277 1 Ph

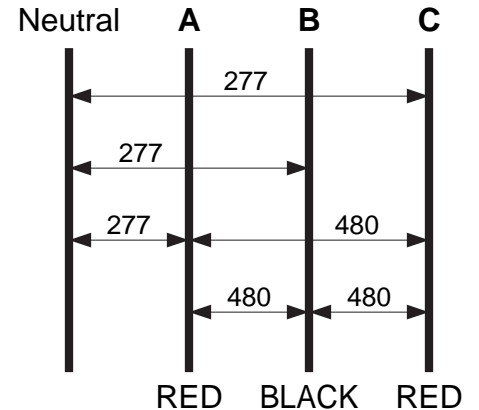

Determining the Age of Your Water Heater

The first two characters of the serial number represent the year and month of manufacture. The remainder of the serial is a sequential production number, seven digits in length before December 2007 (DM), and eight digits in length after.

For example:



Production Year	
A = 1984 or 2004	L = 1994 or 2014
B = 1985 or 2005	M = 1995 or 2015
C = 1986 or 2006	N = 1996 or 2016
D = 1987 or 2007	P = 1997 or 2017
E = 1988 or 2008	S = 1998 or 2018
F = 1989 or 2009	T = 1999 or 2019
G = 1990 or 2010	W = 2000 or 2020
H = 1991 or 2011	X = 2001 or 2021
J = 1992 or 2012	Y = 2002 or 2022
K = 1993 or 2013	Z = 2003 or 2023

Production Month	
A = January	G = July
B = February	H = August
C = March	J = September
D = April	K = October
E = May	L = November
F = June	M = December

For the year column, we do not use the letters: I, O, Q, R U, V

For the month column we do not use the letters: I & N – Z

Due to a computer error there were some OA serial water heaters manufactured. They were built in January of 1997.

NOTICE

This Service Manual is for all LE / SLE models YG and later. For 65, 80, and 120 gallon models, this manual covers YF and later.

For the generation of your model, please see the serial number breakdown below:

		GEN 1	GEN 2
MODEL	LE120L	---	YG +
	LE230LN	---	YG +
	LE240LN	---	YG +
	LE250LN	---	YG +
	LE330S	---	YG +
	LE340S	---	YG +
	LE350S	---	YG +
	LE112T	---	YG +
	LE255T	---	YG +
	LE265T	YF to YG	YG +
	LE280T	YF to YG	YG +
	LE2120T	YF to YG	YG +
	LE16U	---	YG +
	LE120U	---	YG +
	LE220U	---	YG +
SLE280T	YF to YG	YG +	
SLE2120T	YF to YG	YG +	
SLE265T	YF to YG	YG +	

Wattage Limitations at Various Voltages

Light Duty Commercial Electric LE Series (Non-Simultaneous Operation)
 Light Duty Commercial Electric LE Series (Simultaneous Operation)

Maximum Wattage	Element Upper/Lower	Voltage
3,000	1,500/1,500	120
10,000	5,000/5,000	208
11,000	5,500/5,500	240
12,000	6,000/6,000	277, 480

Light Duty Utility Series (Single Element Operation)

Maximum Wattage	Single Element	Voltage
3,000	3,000	120
6,000	6,000	208, 240
6,000	6,000	277
6,000	6,000	480

Surface Mounted Thermostats

Surface mounted thermostats are mounted into a bracket which holds the thermostat against the side of the tank. Surface mounted thermostats respond to tank surface temperatures to sense a call for heat, set point temperature settings and high limit (ECO) activation. It is important that the entire back surface of the thermostat is in full contact or flush with the tank. Improperly mounted thermostat will lead to improper water heater operation.

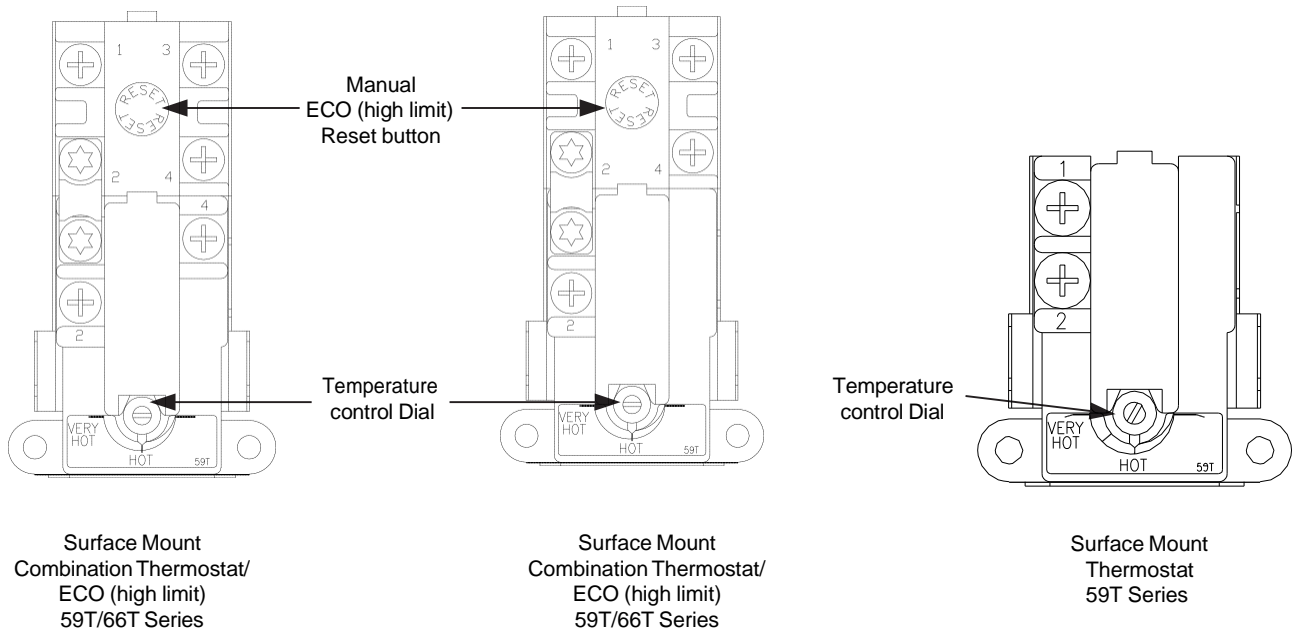

Direct Immersion “Screw-in” Type Heating Element

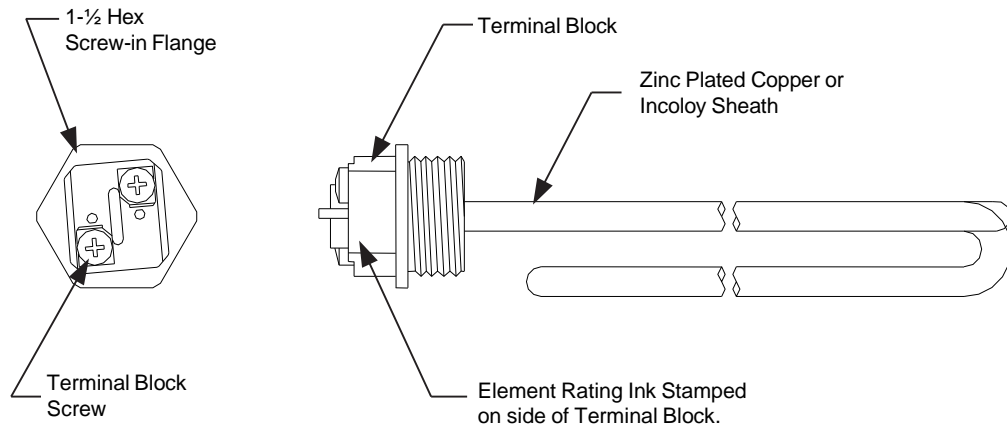

SEQUENCE OF OPERATION

Residential and light duty commercial electric water heaters are designed to operate using several different operating modes. The common modes and sequence of operation are as follows:

1. Single Element Operation.
2. Double Element Non-Simultaneous Operation (single phase).
3. Double Element Non-Simultaneous Operation (3 phase).
4. Double Element Simultaneous Operation (single phase).
5. Double Element Simultaneous Operation (3 phase).

Sequence of Operation- Single Element Operation.

- 1 Line voltage is applied across terminals L1 & L3 of the thermostat. ECO is closed, so there is voltage at terminal L4 and to one side of the element.

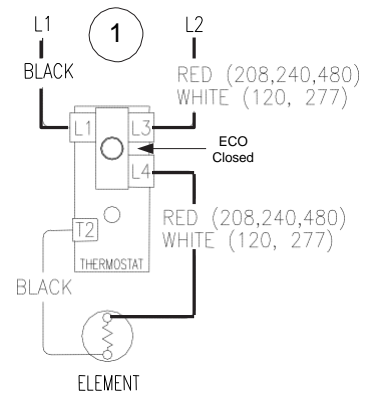

- 2 Tank is cold therefore thermostat is closed at terminal T2 (calling for heat). This completes the circuit and allows current to flow through the element.

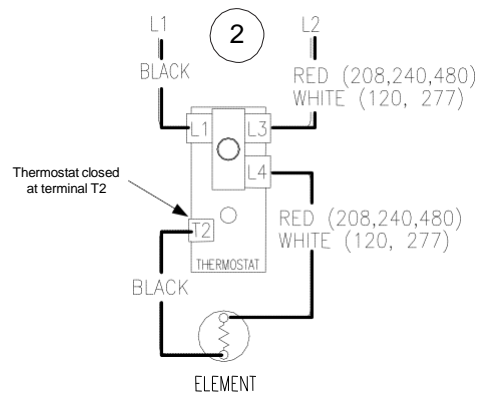

- 3 When the thermostat is satisfied, it opens at terminal T2 interrupting current flow through the element. System is now in stand-by mode, waiting for the next call for heat.

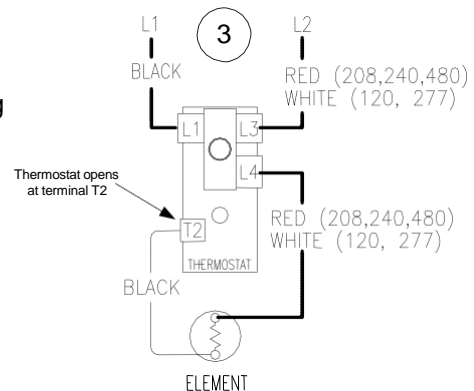

Non-Simultaneous and Simultaneous Operation

Double element electric water heaters are designed to operate in either Non-Simultaneous or Simultaneous mode.

Non-Simultaneous Mode: Allows only one heating element to operate at a time. For example, when the tank is cold, the upper element is energized first, heating the top of the tank. Only when the upper thermostat is satisfied, the upper element is de-energized and power is directed to the lower thermostat, energizing the lower element and heating the bottom portion of the tank until the lower thermostat is satisfied. As hot water is drawn off the tank, it is replaced with cold water delivered through the dip tube to the bottom of the tank. When the tank cools at the lower thermostat level, the lower thermostat will call for heat, energizing the lower element. If enough hot water is drawn from the tank, the top portion of the tank cools and the upper thermostat will call for heat, de-energizing the lower element and allowing only the top element to energize until the upper thermostat is satisfied.

Simultaneous mode: allows both heating elements to operate at the same time. That is, if either thermostat (upper or lower) is calling for heat, the corresponding heating element is energized independent of the other.

Sequence of Operation- Double Element, Non-Simultaneous Operation

- 1 Line voltage is applied across terminals L1 + L3 of the upper thermostat. Line voltage is applied to terminal L1 of the lower thermostat. ECO in both upper and lower thermostat is closed. There is voltage to one side of the upper element and no voltage to the lower.
- 2 Tank is cold, therefore both thermostats are closed at terminal T2 (calling for heat). The circuit is complete through the upper thermostat, allowing current to flow through the upper thermostat only.
- 3 When the upper thermostat is satisfied, it opens at terminal T2, interrupting current flow through the upper element, and closes at terminal T4. This allows voltage to pass to terminal L1 of the lower thermostat. This completes the circuit through the lower thermostat, allowing current flow through the lower element.

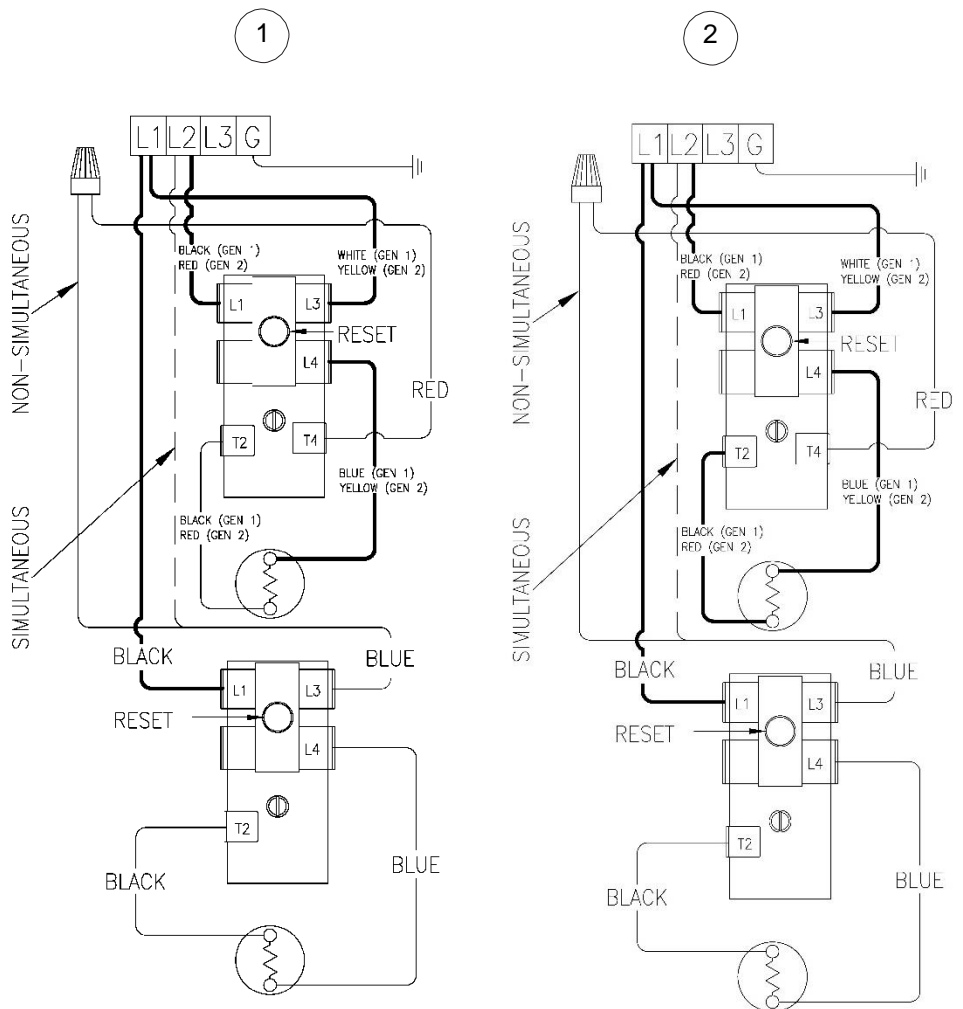

SEQUENCE OF OPERATION

Sequence of Operation- Double Element, Non-Simultaneous Operation (continued)

- 4 When the lower thermostat is satisfied, it opens at terminal T2, interrupting the current flow through the lower element.
- 5 The lower thermostat / element combination will generally cycle on and off more often than the upper. In some cases, such as a cold tank or in high demand periods, the upper thermostat will call for heat (opening at terminal T4 and closing at terminal T2) prior to the lower thermostat being satisfied. This will interrupt current flow through the lower thermostat and element, allowing current to flow through the upper element only. When the upper thermostat is satisfied, it resumes operation as described in sequence 3 previously.

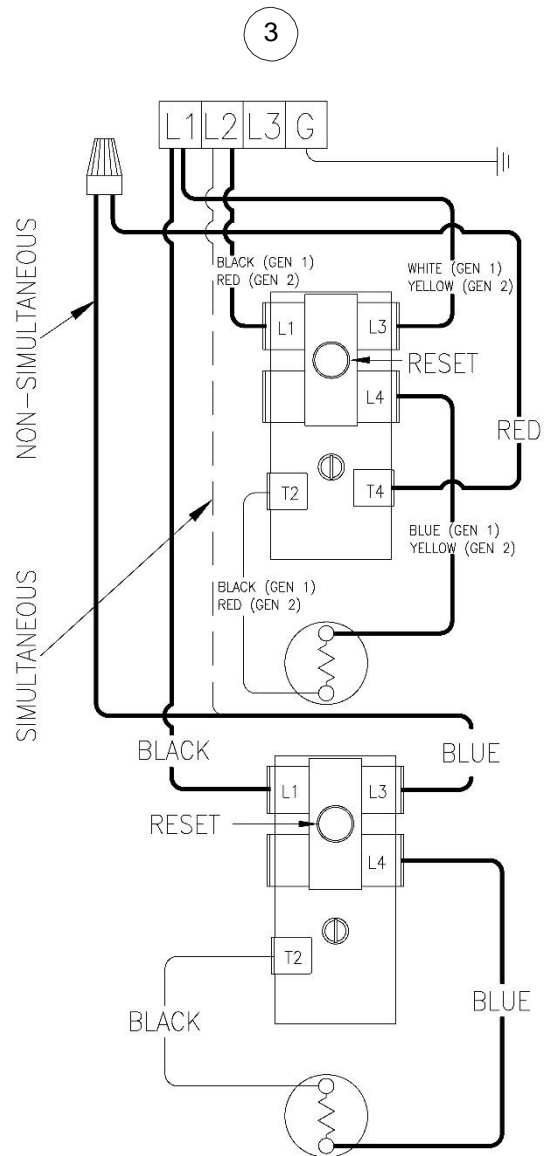

SEQUENCE OF OPERATION

A 4 wire, double element heater wired for simultaneous operation is essentially two single element systems operating independently. The heaters are wired internally with two independent circuits, one circuit for each thermostat/element combination. When installed using a two wire service, the blue and red (or white) wires will be connected together, likewise black and yellow wires will be connected together.

Sequence of Operation- Double Element, Simultaneous Operation, Single Phase

- 1 Line voltage is applied across terminals L3 + L1. ECO in both upper and lower thermostat is closed. There is voltage at terminal L4 of both upper and lower thermostats, and to one side of both the upper and lower elements.
- 2 Tank is cold, therefore both thermostats are closed at terminal T2 (calling for heat). This completes the circuit through the thermostats and allows current to flow through the elements.
- 3 When either thermostat is satisfied, it will open at terminal T2, interrupting current flow through the corresponding element. As both thermostats are satisfied, the system will go into standby mode awaiting the next call for heat. The thermostats will operate independently from one another.

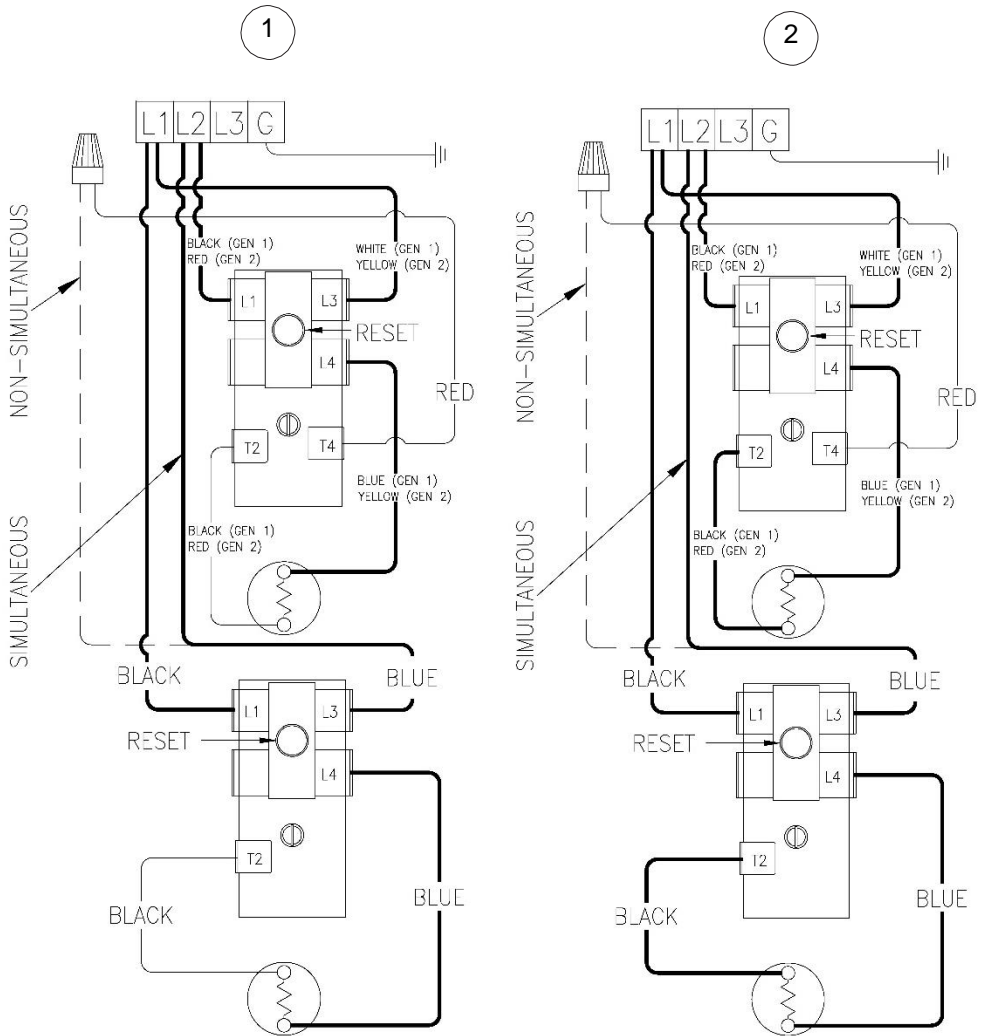

TROUBLESHOOTING

Most common cause for improper electric water heater operation can be linked to heating element failure.

When troubleshooting an electric water heater with the incidence of “No Hot Water” or “Insufficient Amount of Hot Water,” It’s always a good idea to check the heating elements first by following the procedure on page 15.

Common Heating Element Failures:

1. **Dry Firing.** Element may be partially submerged in water or most likely, completely exposed with no water in tank. In some cases, sediment or lime build up around an element can eventually cause an air pocket, and within seconds, result in a dry fired element. At this point the element becomes inoperative. When element replacement is required, be sure the tank is full of water prior to energizing the water heater.
2. **Grounded Element.** An element with a short circuit to ground will in most cases cause the circuit breaker in the service panel to open or shut off. In some cases, there may not be enough current draw for the circuit breaker to open. This will allow the heating element to be in continuous operation resulting in over heated water, limited only by the ECO or Energy Cut Out. Repeated actuation of the ECO is usually the result of a grounded element.
3. **Sediment build up.** Slow hot water recovery can usually be traced back to sediment or lime build up around heating element. Sediment build up can also over time cause a dry fired element.

Figure 1, below shows a common “Screw-In” type heating element identifying certain features commonly referred to throughout this manual.

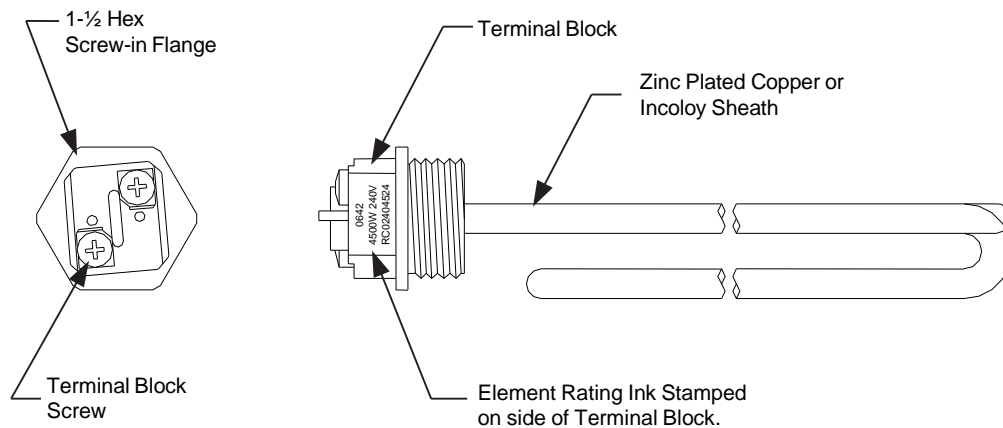

Figure 1
Typical Direct Immersion “Screw-In”
Type Heating Element

Quick Step Plan to Hot Water

1. TURN OFF power to water heater and check all wire connections to ensure they are tight and corrosion free.
2. Turn power "ON" and determine that service voltage is present, and the high limit (ECO) has not actuated (see procedure on page 14).
3. Check for inoperative heating element (see procedure on page 15).
4. Check for proper thermostat operation (see procedures beginning on page 16). NOTE: Thermostat testing procedures assume items 2 and 3 above are in working order.

⚠ WARNING
High voltage exposure. Use caution when making voltage checks to avoid personal injury.

<u>SYMPTOM</u>	<u>PROBABLE CAUSE</u>	<u>CORRECTIVE ACTION</u>	<u>SERVICE PROCEDURE</u>
No Hot Water	<ol style="list-style-type: none"> 1. No Power to heater. 2. Loose wire connections. 3. Inoperative upper heating element. 4. Inoperative upper thermostat. 5. Open ECO. 	<ol style="list-style-type: none"> 1. Check fuses or circuit breakers in service panel. 2. Check all wire connections. 3. Check heating element(s). Replace as needed. 4. Check thermostat(s) operation. Replace as needed. 5. Check ECO. Reset or replace thermostat(s) as needed. 	<ol style="list-style-type: none"> 3. See Service Procedure RE-II, Page 15. 4. See Service Procedure RE-I, Page 14.
Not Enough Hot Water	<ol style="list-style-type: none"> 1. Inoperative lower heating element. 2. Thermostat(s) set to low. 3. Inoperative thermostat(s). 4. Loose wire connection. 5. Sediment or lime build up on element(s). 6. High demand period. 7. Undersized heater. 8. Very cold inlet water to heater. 9. Plumbing connections reversed. 10. Damaged dip tube. 	<ol style="list-style-type: none"> 1. Check heating element(s), replace as needed. 2. Increase thermostat setting. 3. Check thermostat(s), replace as needed. 4. Check all wire connection. 5. Remove heating element(s) and check for lime build up. 6. Reduce demand. 7. Replace with larger heater. 8. Temper water to heater. 9. Correct plumbing connections. 10. Check dip tube, replace as needed. 	<ol style="list-style-type: none"> 1. See Service Procedure RE-II, Page 15. 5. See Service Procedure RE-V, Page 25. 10. See Service Procedure RE-VI, Page 26.
Slow Hot Water Recovery	<ol style="list-style-type: none"> 1. Sediment or lime build up on element(s). 2. Loose wire connections. 3. Inoperative thermostat(s). 4. Derated heating element installed. 	<ol style="list-style-type: none"> 1. Remove heating element(s) and check for lime build up. 2. Check all wire connections. 3. Check thermostat(s), replace as needed. 4. Check terminal block of element for proper voltage and wattage rating. 	<ol style="list-style-type: none"> 1. See Service Procedure RE-V, Page 25.
Over Heated Water or Continued Operation	<ol style="list-style-type: none"> 1. Thermostat not in contact with tank. 2. Grounded heating element(s). 3. Thermostat set too high. 4. Inoperative thermostat(s). 5. Inoperative ECO. 6. Undersized water heater. 	<ol style="list-style-type: none"> 1. Position thermostat flush with tank surface. 2. Check heating element(s). Replace as needed. 3. Adjust thermostat(s) to desired setting. 4. Check thermostat(s), replace as needed. 5. Check ECO, replace thermostat as needed. 6. Replace with larger heater. 	<ol style="list-style-type: none"> 1. See Service Procedure RE-IV, Page 24. 2. See Service Procedure RE-II, Page 15. 4. See Service Procedure RE-I, Page 14.
Noisy (singing or hissing) Elements	<ol style="list-style-type: none"> 1. Lime formation on elements. 	<ol style="list-style-type: none"> 1. Remove and clean heating elements. Replace as needed. 	<ol style="list-style-type: none"> 1. See Service Procedure RE-V, Page 25.

SERVICE PROCEDURE RE-I
Line Voltage & High Limit (ECO)
Testing

Line Voltage Testing

1. Turn "OFF" power to water heater.
2. Remove access cover(s) from front of water heater. Remove insulation and plastic cover from thermostat.
3. Set multi-meter to "Volts AC."
4. Turn power "ON" to water heater.
5. Check voltage across terminals L1 & L3 of upper thermostat (see Figure 2).
 - A) Rated voltage IS present, power to the water heater is okay.
 - B) Rated voltage NOT present, Check circuit breaker at service panel.

⚠ WARNING
High voltage exposure. Use caution when making voltage checks to avoid personal injury.

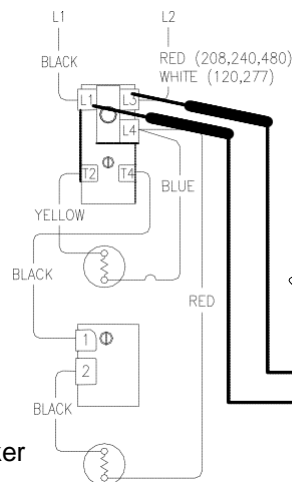

Figure 2

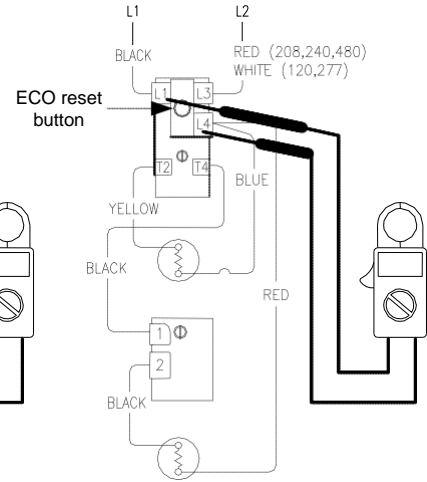

Figure 3

High Limit (ECO) Testing

1. Check voltage across terminals L1 & L4 upper thermostat (see Figure 3).
 - A) Rated Voltage IS present, ECO is okay.
 - B) Rated voltage NOT present, proceed to step 2.
2. Turn power "OFF" to water heater and firmly press ECO reset button on thermostat(s). Turn power "ON" and recheck voltage across terminals L1 & L4 of upper thermostat (see Figure 3).
 - A) Rated voltage IS present, the ECO has previously opened indicating the water in the tank, at some point did overheat, check the following:
 1. Thermostat must be in full contact with tank.
 2. Be sure heating element(s) is not shorted to ground (see page 15).
 3. Proper thermostat operation (see procedures beginning on page 16).
 - B) Rated voltage NOT present, water in tank may be over heated.
 1. If water is hot, turn "OFF" power to water heater and flow water through tank to cool below set point of upper thermostat. Recheck voltage per step 1.
 2. If water is cool, Replace upper thermostat.

Testing For Open Or Burned Out Element

- Step 1. **TURN OFF POWER TO WATER HEATER**
- Step 2. Remove access cover(s) from front of water heater. Remove insulation and plastic cover from thermostat.
- Step 3. Disconnect wires from heating element(s).
- Step 4. Set multi-meter to “ohms” setting.
- Step 5. Touch probes of multi-meter to screw terminals of heating element(s) (see Figure 4).
- Step 6. Reading should be 12.8 ohms (±6%) for a 240 volt, 4500 watt element:

$$\text{Ohms} = \frac{\text{Volts}^2}{\text{Watts}}$$

A reading outside the range using the formula beyond (±6%), indicates a bad element and the element must be replaced.

⚠ WARNING
High voltage exposure. Be sure power is turned OFF to water heater prior to performing this procedure.

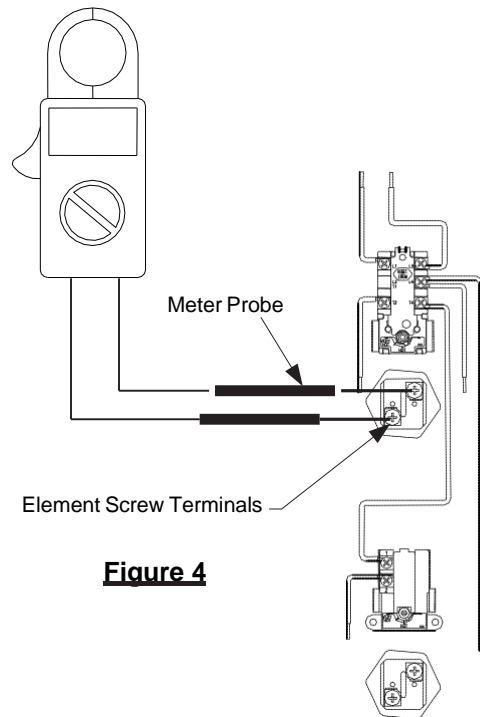

Figure 4

Testing For Heating Element Short Circuit To Ground

- Step 1. **TURN OFF POWER TO WATER HEATER**
- Step 2. Remove access cover(s) from front of water heater. Remove insulation and plastic cover from thermostat.
- Step 3. Disconnect wires from heating element(s).
- Step 4. Set multi-meter to “ohms” setting.
- Step 5. Touch one probe of multi-meter to either screw terminal of heating element and the other on the element flange (see figure 5). There should be no reading on the ohm meter. Any reading indicates a grounded element and the element must be replaced. Repeat this step for the other screw terminal.

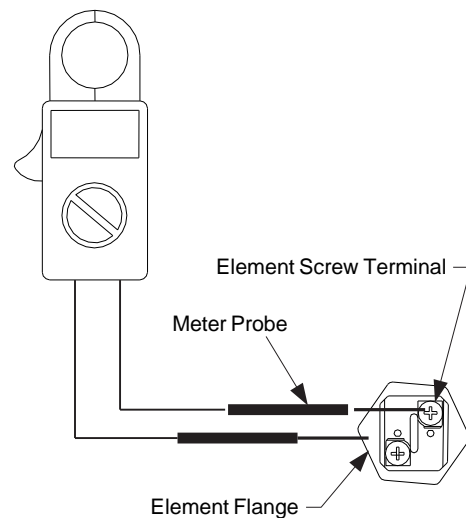

Figure 5

Double Element, Non-Simultaneous, Single Phase Operation.

⚠ WARNING
High voltage exposure. Use caution to avoid personal injury during this procedure.

Water In Tank Is Cold With Power ON.

1. This procedure assumes line voltage, ECO and elements are in working order.
2. Turn power "ON" to water heater.
3. Set multi-meter to "Volts AC."
4. Check across terminals L4 and T2 of upper thermostat (see Figure 6).
 - A) Rated voltage NOT present, recheck ECO (see page 14). If ECO is okay, replace thermostat.
 - B) Rated voltage IS present, proceed to next step.
5. Check across element terminals (see Figure 7).
 - A) Rated voltage NOT present, check wire connections from thermostat to element.
 - B) Rated voltage IS present, repeat element testing see page 15.

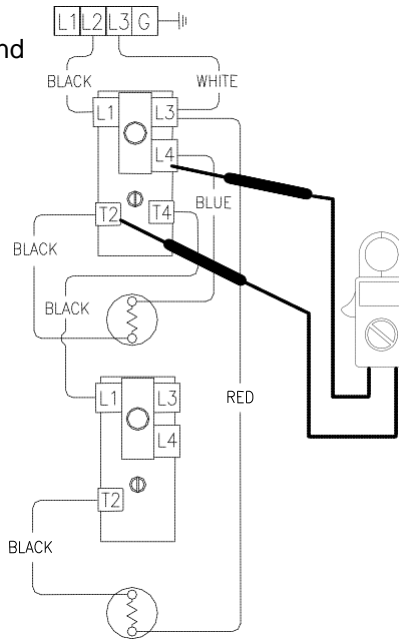

Figure 6

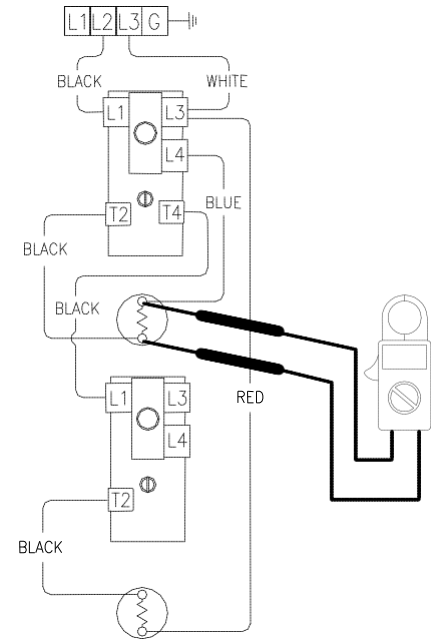

Figure 7

Tank Does Not Deliver Enough Hot Water.

1. This procedure assumes line voltage, ECO and elements are in working order.
2. Turn power "ON" to water heater and set multi-meter to "Volts AC."
3. Adjust temperature setting of upper & lower thermostat to the highest setting. Water temperature in tank must be below thermostat setting for this test.
4. See Figure 6 above. Check voltage across terminals L4 & T2 of upper thermostat.
 - A) Rated voltage IS present, okay, upper thermostat is calling for heat. Go to step 5 below.
 - B) Rated voltage NOT present, replace upper thermostat.
5. Adjust temperature setting of upper thermostat to the minimum setting. Water temperature in tank must be above thermostat setting for this test.
6. Check voltage across terminals L3 & T4 of upper thermostat (see Figure 8).
 - A) Rated voltage NOT present, replace upper thermostat.
 - B) Rated voltage IS present, upper thermostat is okay. Go to step 7 on next page.

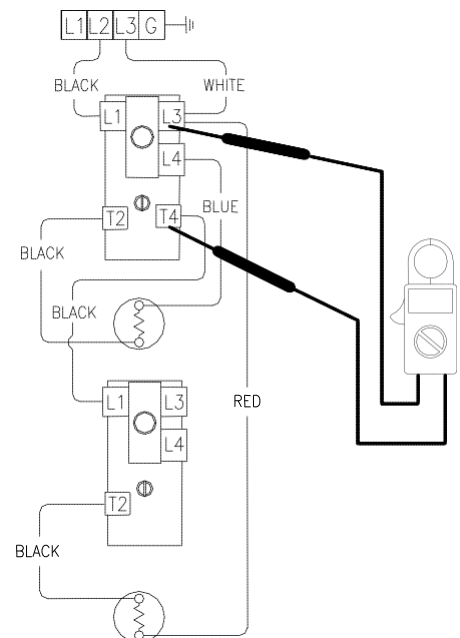

Figure 8

SERVICE PROCEDURE RE-III
Light Duty Commercial
Thermostat Testing

Double Element, Non-Simultaneous, Single Phase Operation (continued)

⚠ WARNING
High voltage exposure. Use caution to avoid personal injury during this procedure.

Tank Does Not Deliver Enough Hot Water (continued)

7. Check voltage across terminal L3 of upper thermostat & T2 of lower Thermostat. (see Figure 9).
 - A) Rated voltage NOT present, replace lower thermostat.
 - B) Rated voltage is present, okay, go to step 8.
8. Check voltage across lower element (see Figure 10).
 - A) Rated voltage NOT present, Check wire connections between thermostats & element.
 - B) Rated voltage IS present, repeat element testing see page 15.

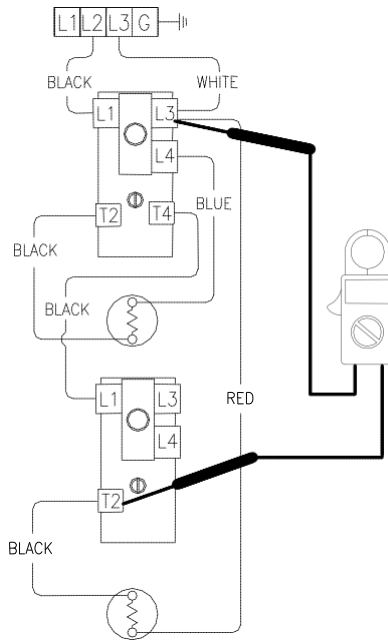

Figure 9

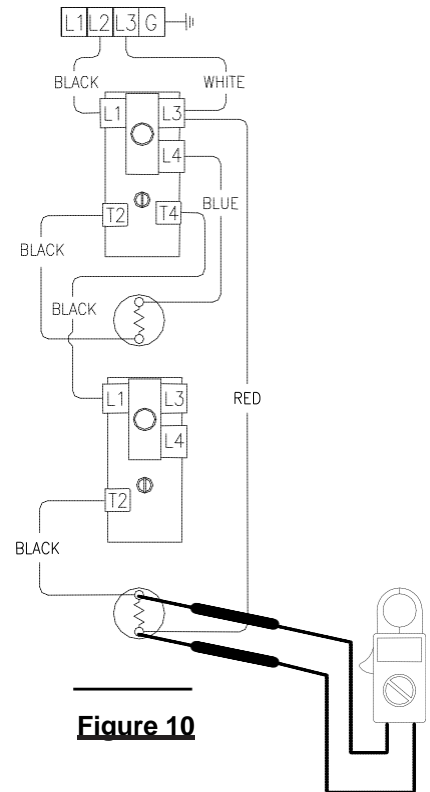

Figure 10

⚠ WARNING
Be sure thermostats are reset to their original temperature settings as found prior to thermostat testing

Water Temperature In Tank Is Above Thermostat Setting.

1. This procedure assumes line voltage, ECO and elements are in working order.
2. Adjust upper and lower thermostat to the lowest setting.
3. Turn power "ON" to water heater and Set multi-meter to "Volts AC."
4. See Figure 32 above. Check across terminal L3 of upper thermostat & T2 of lower thermostat.
 - A) Rated voltage IS present, replace lower thermostat.
 - B) Rated voltage NOT present, okay, go to step 5 below.
 - C) Lower than rated voltage IS present, recheck for grounded lower element see page 15.
5. Check across terminal L4 & T2 of upper thermostat (see Figure 11).
 - A) Rated voltage IS present, replace upper thermostat.
 - B) Rated voltage NOT present, upper thermostat is okay.
 - C) Lower than rated voltage IS present, recheck for grounded upper element see page 15.

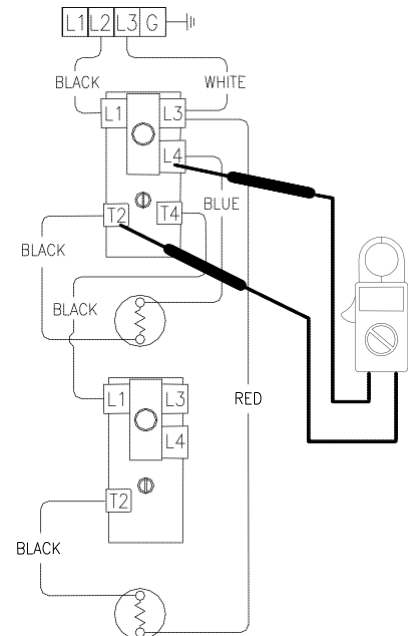

Figure 11

Double Element. Simultaneous. Single Phase Operation.

Water In Tank Is Cold Or Not Enough Hot Water With Power ON.

1. This procedure assumes line voltage, ECO and elements are in working order.
2. Adjust temperature setting for both thermostats to the highest setting.
3. Turn power "ON" to water heater.
4. Set multi-meter to "Volts AC."
5. Check across terminals L4 and T2 of upper thermostat (see Figure 12).
 - A) Rated voltage NOT present, recheck upper ECO (see page 14). If ECO is okay, replace upper thermostat.
 - B) Rated voltage IS present, proceed to next step.
6. Check across upper element terminals (see Figure 13).
 - A) Rated voltage NOT present, check wire connections from thermostat to upper element.
 - B) Rated voltage IS present, repeat element testing see page 15.
7. Check across terminal L3 of upper thermostat and T2 of lower thermostat (see Figure 14).
 - A) Rated voltage NOT present, check ECO (see page 14) & wire connections at upper & lower thermostats. If okay, replace lower thermostat.
 - B) Rated voltage IS present, proceed to next step.
8. Check across lower element terminals (see Figure 15).
 - A) Rated voltage NOT present, check lower element wire connections to the thermostats.
 - B) Rated voltage IS present, repeat lower element testing see page 15

⚠ WARNING
High voltage exposure. Use caution to avoid personal injury during this procedure.

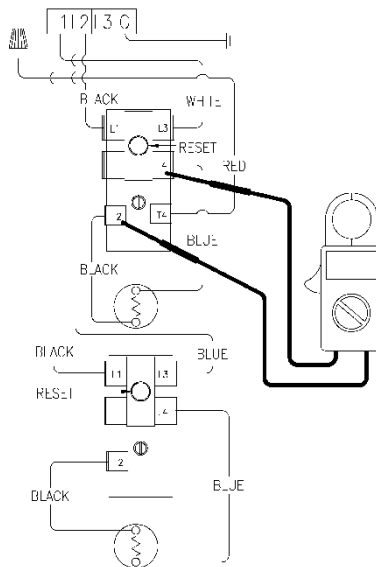

Figure 12

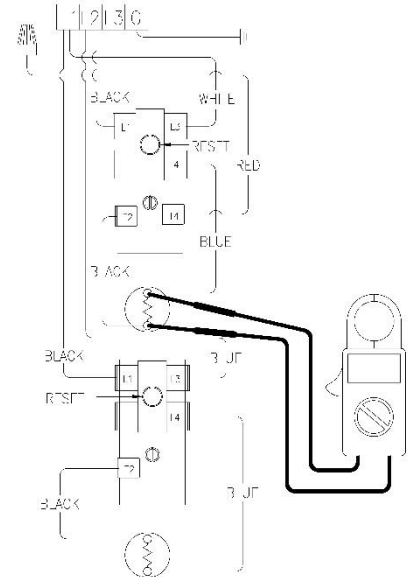

Figure 13

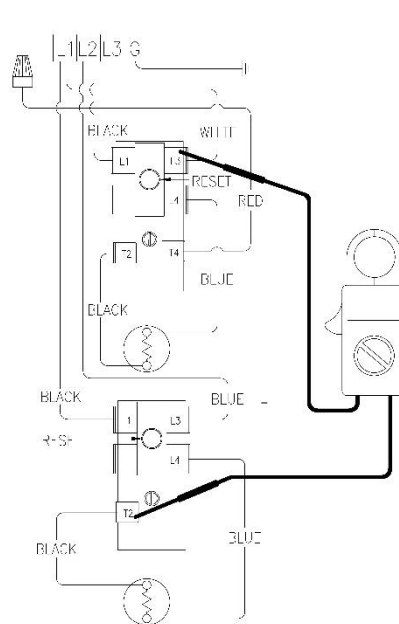

Figure 14

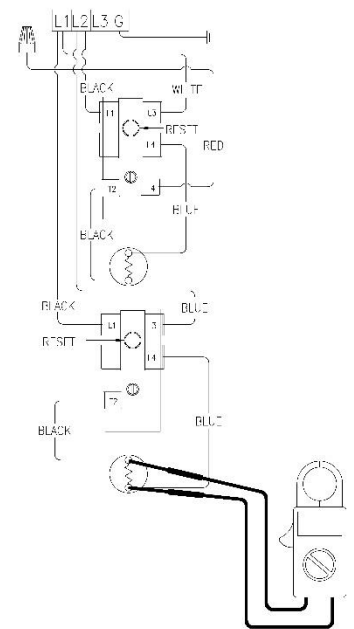

Figure 15

⚠ WARNING
Be sure thermostats are reset to their original temperature settings as found prior to thermostat testing

SERVICE PROCEDURE RE-III
Light Duty Commercial
Thermostat Testing

Double Element, Simultaneous, Single Phase Operation (continued)

Water Temperature In Tank Is Above Thermostat Setting.

1. This procedure assumes line voltage, ECO and elements are in working order.
2. Adjust upper and lower thermostat to the lowest setting.
3. Turn power "ON" to water heater.
4. Set multi-meter to "Volts AC."
5. Check across terminals L4 and T2 of upper thermostat (see Figure 16).
 - A) Rated voltage IS present, replace upper thermostat.
 - B) Rated voltage NOT present, upper thermostat is okay. Go to step 6 below.
 - C) Lower than rated voltage IS present, recheck for grounded upper element.
6. Check across terminal L3 of upper thermostat and T2 of lower thermostat (see Figure 17).
 - A) Rated voltage IS present, replace lower thermostat.
 - B) Rated voltage NOT present, lower thermostat is okay.
 - C) Lower than rated voltage IS present, recheck for grounded lower element.

⚠ WARNING
High voltage exposure. Use caution to avoid personal injury during this procedure.

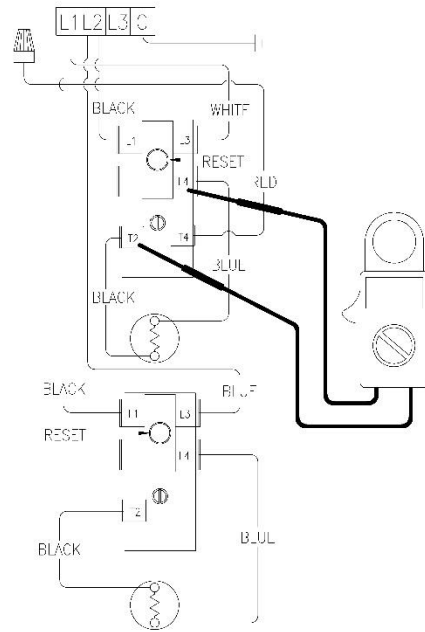

Figure 16

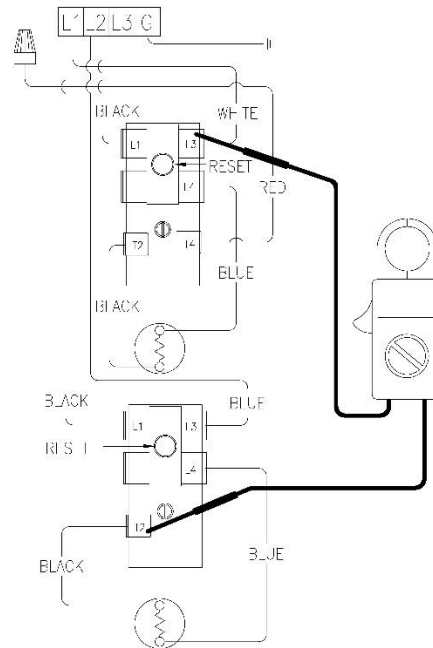

Figure 17

Double Element, Non-Simultaneous, Three Phase Operation.

Water In Tank Is Cold With Power ON.

1. This procedure assumes line voltage, ECO and elements are in working order.
2. Turn power "ON" to water heater.
3. Set multi-meter to "Volts AC."
4. Check across terminals L4 and T2 of upper thermostat (see Figure 18).
 - A) Rated voltage NOT present, recheck upper ECO. If ECO is okay, replace thermostat.
 - B) Rated voltage IS present, proceed to next step.
5. Check across element terminals (see Figure 19).
 - A) Rated voltage NOT present, check wire connections from thermostat to element.
 - B) Rated voltage IS present, repeat element testing.

⚠ WARNING
High voltage exposure. Use caution to avoid personal injury during this procedure.

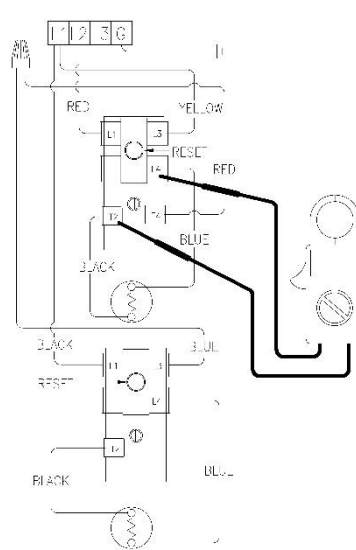

Figure 18

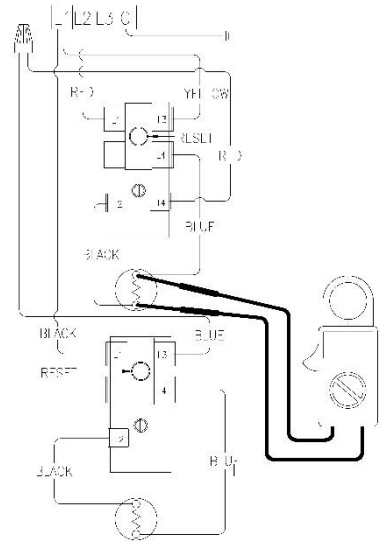

Figure 19

Tank Does Not Deliver Enough Hot Water.

1. This procedure assumes line voltage, ECO and elements are in working order.
2. Turn power "ON" to water heater and set multi-meter to "Volts AC."
3. Adjust temperature setting of upper & lower thermostat to the highest setting. Water temperature in tank must be below thermostat setting for this test.
4. See Figure 18 above. Check voltage across terminals L4 & T2 of upper thermostat.
 - A) Rated voltage IS present, okay, upper thermostat is calling for heat. Go to step 5 below.
 - B) Rated voltage NOT present, replace upper thermostat.
5. Adjust temperature setting of upper thermostat to the minimum setting. Water temperature in tank must be above thermostat setting for this test.
6. Check voltage across terminals L3 & T4 of upper thermostat (see Figure 20).
 - A) Rated voltage NOT present, replace upper thermostat.
 - B) Rated voltage IS present, upper thermostat is okay. Go to step 7 on next page.

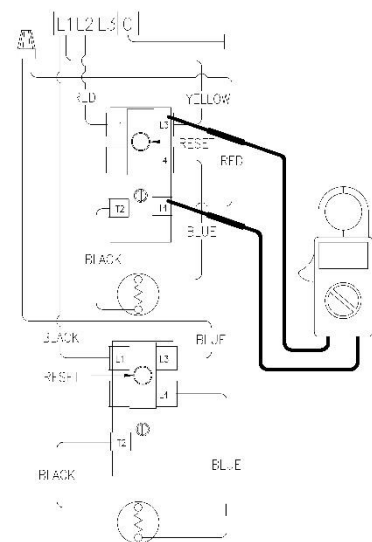

Figure 20

SERVICE PROCEDURE RE-III
Light Duty Commercial
Thermostat Testing

Double Element, Non-Simultaneous, Three Phase Operation (continued).

Tank Does Not Deliver Enough Hot Water (continued).

7. Check voltage across terminal L1 of upper thermostat & T2 of lower thermostat. (see Figure 21).
 - A) Rated voltage NOT present, Replace lower thermostat.
 - B) Rated voltage is present, okay, go to step 8.
8. Check voltage across lower element (see Figure 22).
 - A) Rated voltage NOT present, check wire connections between thermostats & element.
 - B) Rated voltage IS present, repeat element testing.

⚠ WARNING
High voltage exposure. Use caution to avoid personal injury during this procedure.

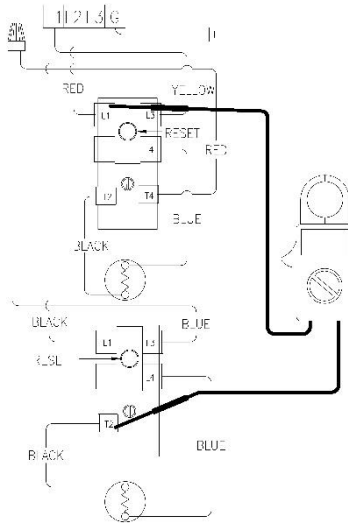

Figure 21

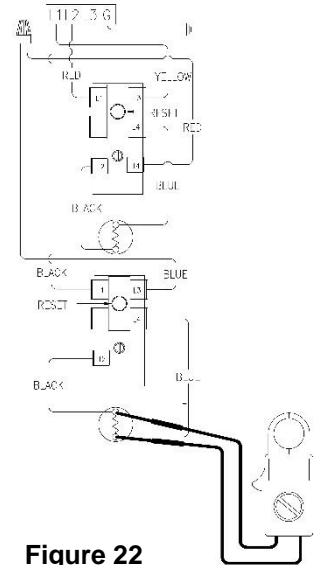

Figure 22

⚠ WARNING
Be sure thermostats are reset to their original temperature settings as found prior to thermostat testing

Water Temperature In Tank Is Above Thermostat Setting.

1. This procedure assumes line voltage, ECO and elements are in working order.
2. Adjust upper and lower thermostat to the lowest setting.
3. Turn power "ON" to water heater and Set multi-meter to "Volts AC."
4. See Figure 21 above. Check across terminal L1 of upper thermostat & T2 of lower thermostat.
 - A) Rated voltage IS present, replace lower thermostat.
 - B) Rated voltage NOT present, okay, go to step 5 below.
 - C) Lower than rated voltage IS present, recheck for grounded lower element.
5. Check across terminal L4 & T2 of upper thermostat (see Figure 23).
 - A) Rated voltage IS present, replace upper thermostat.
 - B) Rated voltage NOT present, upper thermostat is okay.
 - C) Lower than rated voltage IS present, recheck for grounded upper element.

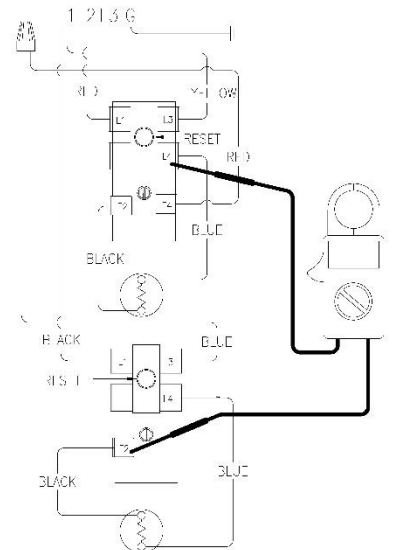

Figure 23

Double Element, Simultaneous, Three Phase Operation.

Water In Tank Is Cold Or Not Enough Hot
Water With Power ON.

1. This procedure assumes line voltage, ECO and elements are in working order.
2. Adjust temperature setting for both thermostats to the highest setting.
3. Turn power "ON" to water heater.
4. Set multi-meter to "Volts AC."
5. Check across terminals L4 and T2 of upper thermostat (see Figure 24).
 - A) Rated voltage NOT present, recheck upper ECO (see page 14). If ECO is okay, replace upper thermostat.
 - B) Rated voltage IS present, proceed to next step.
6. Check across upper element terminals (see Figure 25).
 - A) Rated voltage NOT present, check wire connections from thermostat to upper element.
 - B) Rated voltage IS present, repeat element testing
7. Check across terminal L4 of lower thermostat and T2 of lower thermostat (see Figure 26).
 - A) Rated voltage NOT present, check ECO (see page 14) & wire connections at upper & lower thermostats. If okay, replace lower thermostat.
 - B) Rated voltage IS present, proceed to next step.
8. Check across lower element terminals (see Figure 27).
 - A) Rated voltage NOT present, check lower element wire connections to thermostat.
 - B) Rated voltage IS present, repeat lower element testing.

⚠ WARNING
High voltage exposure. Use caution to avoid personal injury during this procedure.

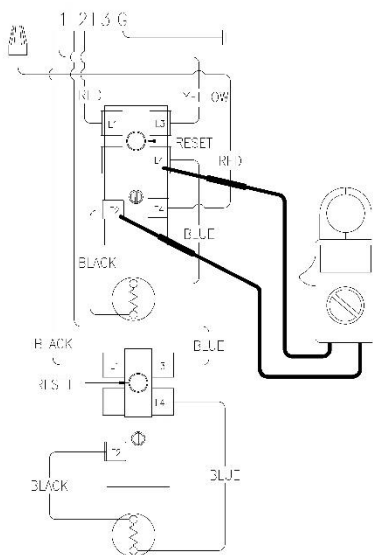

Figure 24

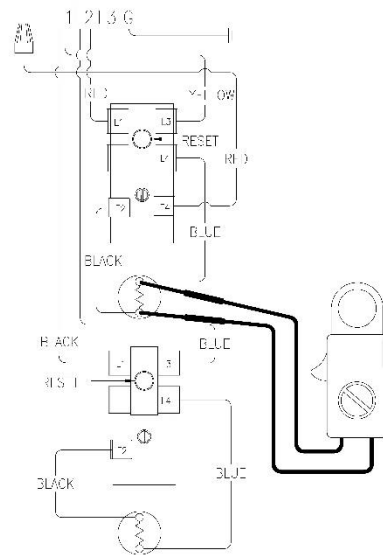

Figure 25

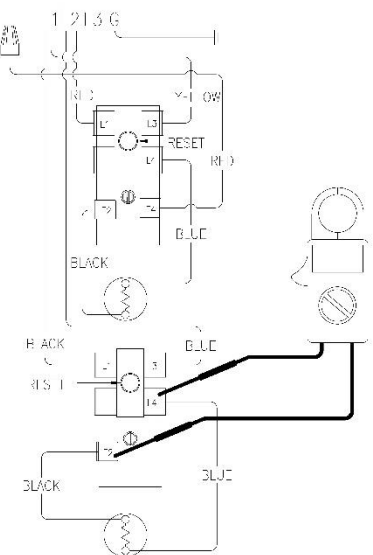

Figure 26

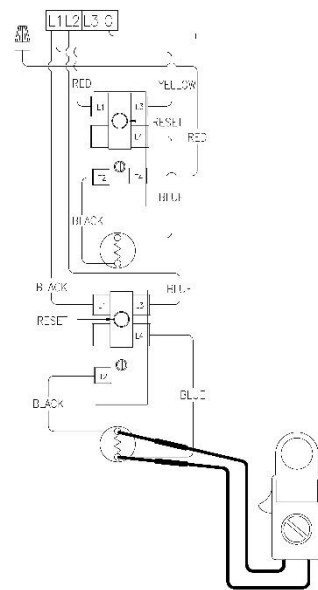

Figure 27

WARNING
Be sure thermostats are reset to their original temperature settings as found prior to thermostat testing

SERVICE PROCEDURE RE-III
Light Duty Commercial
Thermostat Testing

Double Element, Simultaneous, Three Phase Operation (continued).

Water Temperature In Tank Is Above Thermostat Setting.

1. This procedure assumes line voltage, ECO and elements are in working order.
2. Adjust upper and lower thermostat to the lowest setting.
3. Turn power "ON" to water heater.
4. Set multi-meter to "Volts AC."
5. Check across terminals L4 and T2 of upper thermostat (see Figure 28).
 - A) Rated voltage IS present, replace upper thermostat.
 - B) Rated voltage NOT present, upper thermostat is okay. Go to step 6 below.
 - C) Lower than rated voltage IS present, recheck for grounded upper element.
6. Check across terminals L4 & T2 of lower thermostat (see Figure 29).
 - A) Rated voltage IS present, replace lower thermostat.
 - B) Rated voltage NOT present, lower thermostat is okay.
 - C) Lower than rated voltage IS present, recheck for grounded lower element.

⚠ WARNING
High voltage exposure. Use caution to avoid personal injury during this procedure.

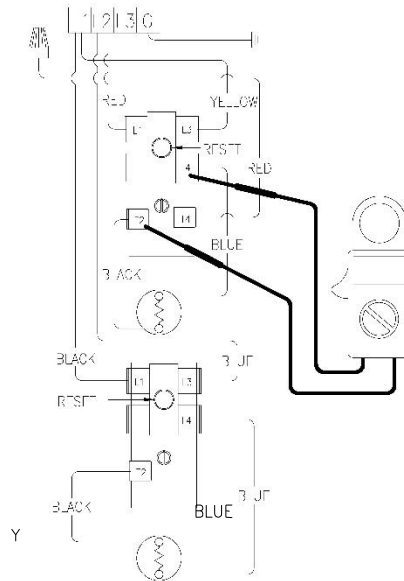

Figure 28

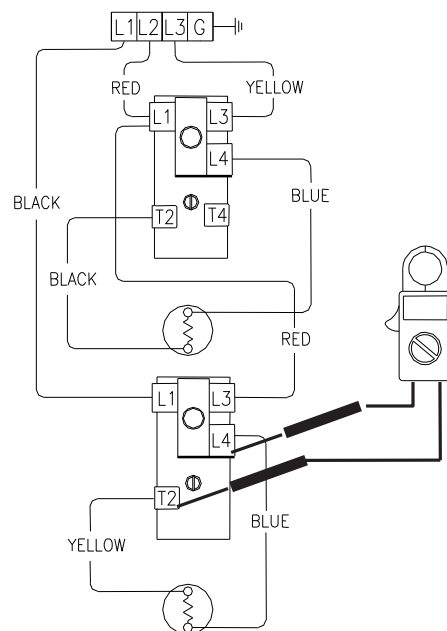

Figure 29

Thermostat Removal

1. Turn power "OFF" to water heater.
2. Remove access cover and insulation.
3. Remove plastic thermostat protector from thermostat.
4. Disconnect wires from thermostat terminals. It may be necessary to label wires for proper re-connection to new thermostat.
5. Note thermostat temperature setting for proper setting of new thermostat.
6. Slide thermostat upwards and out of mounting bracket.



WARNING

High voltage exposure. Be sure power is "OFF" when performing this procedure.

Thermostat Replacement

1. Use a stiff brush to remove any debris or loose scale from tank surface where new thermostat will be installed.
2. Slide new thermostat down into thermostat bracket until it snaps into place. **IMPORTANT!** Thermostat must sit completely flat or flush to tank surface. An improperly installed thermostat will cause improper water heater operation.
3. Refer to the wire diagram located on the inside of the access cover and reconnect wires to the thermostat. Be sure wire connections are snug and corrosion free. Do not over tighten, doing so may damage thermostat.
4. Set thermostat to the original thermostat setting found on the old thermostat.
5. Re-install plastic thermostat protector.
6. Re-install insulation and access cover.
7. Restore power to water heater and verify proper heater operation.

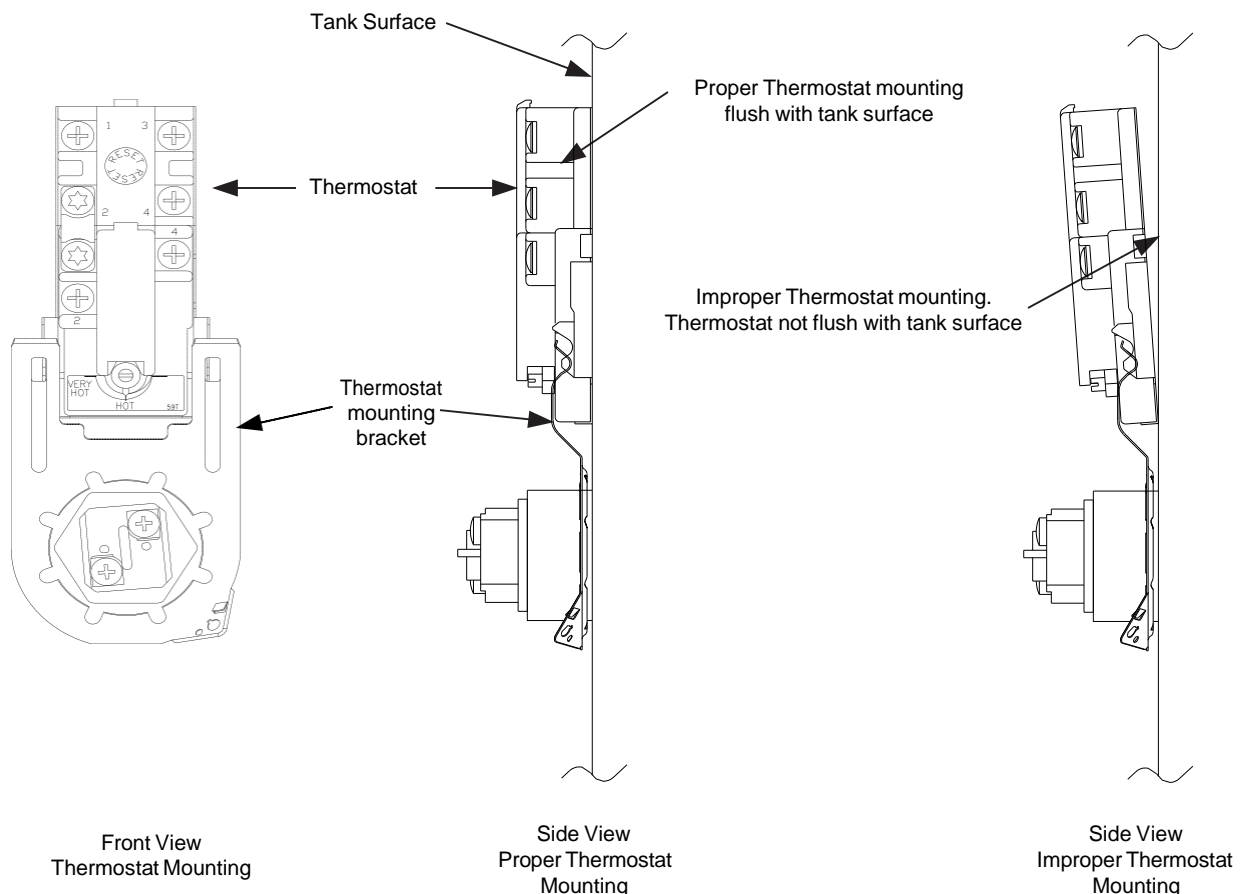

SERVICE PROCEDURE RE-V
Heating Element Removal
and Replacement

Heating Element Removal

1. Turn power "OFF" To water heater.
2. Turn off cold water supply to heater. Connect hose to drain spigot of water heater and route to an open drain. Open a nearby hot water faucet to vent heater for draining. Open drain spigot of water heater and allow heater to drain to a point below the element(s).
3. Close drain spigot and remove hose.
4. Remove access cover and insulation.
5. Remove plastic thermostat protector from thermostat.
6. Disconnect wires from element terminals.
7. Remove element from tank using 1-½ deep well socket or appropriate wrench. Unscrew element counter-clockwise to remove from tank.
8. Be sure to remove old element gasket from the tank. It is not recommended to be re-used.

⚠ WARNING
High voltage exposure. Be sure power is **"OFF"** when performing this procedure.

⚠ WARNING
Heater components and stored water may be **HOT** when performing the following steps in this procedure. Take necessary precaution to prevent personal injury.

Heating Element Replacement

1. Check element terminal block for proper electrical rating. NOTE: Some elements have dual ratings, be sure to check all surfaces of the element terminal block (see illustration below).
2. Apply new element gasket to the new element. Be sure gasket is seated flat against element flange without rolls or gaps (see illustration below).
3. Clean any debris from element fitting on tank. Lubricate element threads as needed with thread lubricant.
4. Thread new element clockwise into tank. Tighten element using 1-½ deep well socket or appropriate wrench. Do not over tighten, over tightening may damage element gasket.
5. Reconnect wires to element, be sure wires are snug and corrosion free. Do not over tighten, doing so may damage terminal block.
6. Resume water supply to heater, be sure tank is full of water and check for leaks.
7. Re-install plastic thermostat protector.
8. Re-install insulation and access cover.
9. To resume operation, **BE SURE TANK IS FULL OF WATER** and restore power to water heater. Verify proper heater operation.

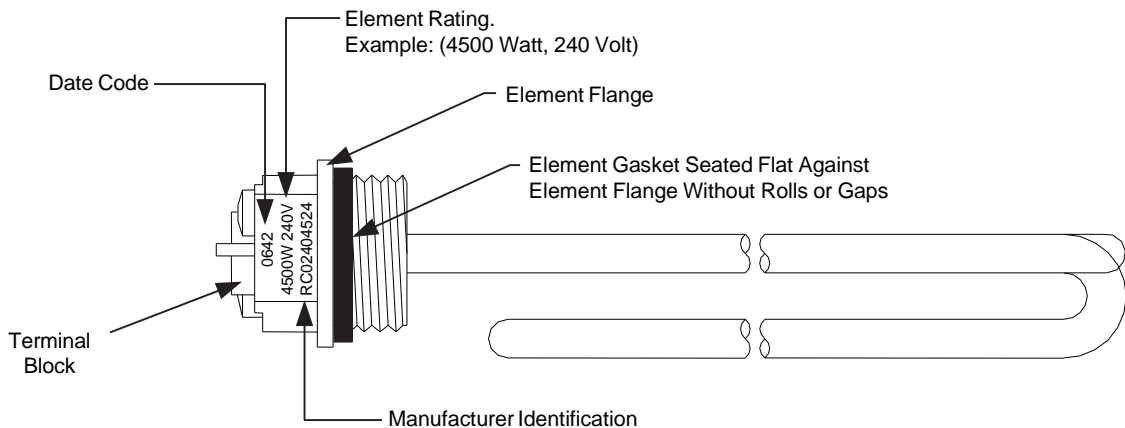

Diptube Inspection and Replacement

WARNING

Heater components and stored water may be HOT when performing the following steps in this procedure. Take necessary precaution to prevent personal injury.

- Step 1. Turn power “OFF” to water heater.
- Step 2. Turn off cold water supply to heater. Connect hose to drain spigot of water heater and route to an open drain. Open a nearby hot water faucet to vent heater for draining. Open drain spigot of water heater and allow heater to drain to a point below the inlet connection nipple.
- Step 3. Close drain spigot and remove hose.
- Step 4. Disconnect inlet nipple from plumbing system.
- Step 5. With an appropriate wrench, remove inlet nipple/dip tube from the water heater. Use caution not to damage nipple threads.
- Step 6. Visually inspect inlet nipple/dip tube. Inlet nipple/dip tube should be free of cracks and any blockage. Hydro-jets located near the bottom of the dip tube should be open and free of any blockage. Anti-siphon hole located approximately 6" from the bottom of nipple, should be free of any blockage.

Any damage such as cracks, restriction due to deformation or unintentional holes are not field repairable and the inlet nipple/dip tube must be replaced.
- Step 7. Upon completion of inspection or subsequent replacement, reinstall inlet nipple/dip tube into heater. Ensure pipe dope is used on the nipple's threads. Connect nipple to plumbing system, close spigot and remove drain hose, resume water supply and refill heater with water.
- Step 8. To resume operation, **BE SURE TANK IS FULL OF WATER** and turn power “ON” to water heater.

Anode Inspection and Replacement

- Step 1. Turn power “OFF” to water heater.
- Step 2. Turn off cold water supply to heater. Connect hose to drain spigot of water heater and route to an open drain. Open a nearby hot water faucet to vent heater for draining. Open drain spigot of water heater and allow heater to drain to a point below the outlet connection nipple.
- Step 3. Close drain spigot and remove hose.
- Step 4. Disconnect outlet nipple from plumbing system.
- Step 5. With an appropriate wrench, remove outlet nipple/anode from the water heater. Use caution not to damage nipple threads.
- Step 6. Visually inspect outlet nipple/anode. Outlet nipple/anode should show signs of depletion, this is normal. If depletion is $\frac{1}{2}$ of the original anode diameter (original diameter approximately $\frac{3}{4}$ "), replacement is recommended. If any of the steel core of the anode is exposed, replacement is recommended.
- Step 7. Upon completion of inspection or subsequent replacement, reinstall outlet nipple/anode into heater. Ensure pipe dope is used on the nipple's threads. Connect nipple to plumbing system, close spigot and remove drain hose, resume water supply and refill heater with water.
- Step 8. To resume operation, **BE SURE HEATER IS FULL OF WATER** and turn power “ON” to water heater.

Generic Parts List

TOP LOCATION

- Double element water heater, non-simultaneous single phase and three phase operation.

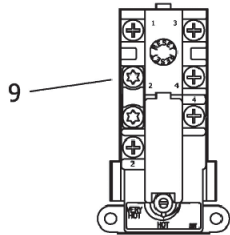

TOP LOCATION

- Double element water heater, simultaneous operation.

BOTTOM LOCATION

- Single element water heater.
- Double element water heater, non-simultaneous three phase operation.
- Double element water heater, simultaneous operation.

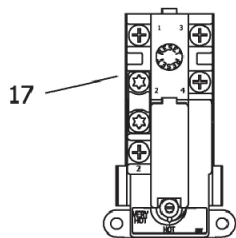

BOTTOM LOCATION

- Double element water heater, non-simultaneous single phase operation.

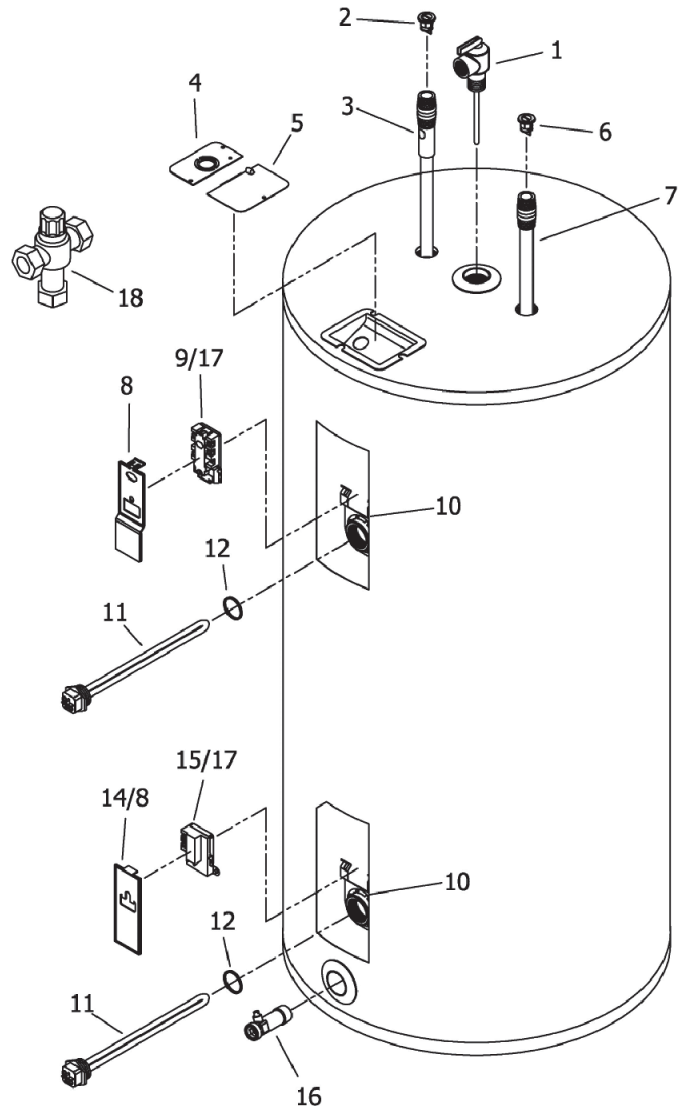
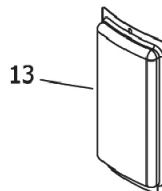
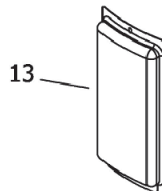
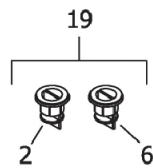
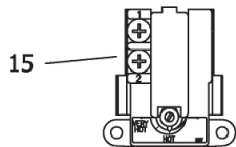

1. T&P Relief Valve
2. Heat Trap Insert (Outlet)
3. Hot Water Outlet/Anode
4. Cover Conduit/Ground
5. Junction Box Cover
6. Heat Trap Insert (Inlet)
7. Cold Water Inlet Diptube
8. Upper Thermostat Protector
9. Upper Thermostat
10. Thermostat Mounting Bracket

11. Heating Element
12. Element Gasket
13. Access Cover
14. Lower Thermostat Protector
15. Lower Thermostat (59T)
16. Brass Drain Valve
17. Thermostat w/High Limit (59T/66T)
18. ASSE Approved Mixing Device
19. Kit Heat Trap



United States

Sales 1-800-523-2931
Technical Support 1-800-334-3393
Email techsupport@bradfordwhite.com
Warranty 1-800-531-2111
Email warranty@bradfordwhite.com
Service Parts 1-800-538-2020
Email parts@bradfordwhite.com

Canada

Sales 1-866-690-0961 1-905-203-0600
Fax 905-636-0666
Warranty 1-800-531-2111
Email warranty@bradfordwhite.com
Technical Support 1-800-334-3393
Email techsupport@bradfordwhite.com
Service Parts and Orders ca.orders@bradfordwhite.com

For U.S. and Canada field service, contact your professional installer or local Bradford White sales representative.

International

General Contact international@bradfordwhite.com