



BRADFORD WHITE[®]
W A T E R H E A T E R S

UPV Series
Ultra Low NO_x Through-The-Wall
(TTW[®]) Gas Water Heaters - 19 Models



SERVICE

MANUAL

Troubleshooting Guide
and Instructions for Service

(To be performed ONLY by
qualified service providers)

Models Covered by This Manual:

URG1PV40S*N19
URG1PV50S*N19
URG2PV40T*N19
URG2PV50T*N19
URG2PV50H*N19
ULG2PV50H*N19

* Denotes Warranty Year

**BRADFORD WHITE**[®] featuring:
AquaVENT™ MAX
From FASCO™

 **WARNING**
CANCER AND REPRODUCTIVE HARM
WWW.P65WARNINGS.CA.GOV

As required by the state of California Proposition 65.



Table of Contents

	Page
Introduction.....	4
Tools Required for Service.....	5
Specifications.....	6
Control Timings.....	9
Sequence of Operation.....	10
Troubleshooting.....	12
Burner Inspection, Cleaning, & Replacement.....	14
Pilot Inspection, Testing, and Replacement	16
Pressure Switch Testing & Replacement.....	17
Blower Testing & Replacement.....	19
Replacement Wire Harness Installation.....	21
Blower Temperature Switch Testing & Replacement.....	23
Gas Control Testing & Replacement.....	25
Flammable Vapor / Simulative Resistance Device Testing & Replacement...	28
Safety Circuit Voltage Trace.....	29
115 VAC Circuit Trace	30
Diptube Inspection & Replacement.....	31
Anode Inspection & Replacement.....	32
Flue Baffle Inspection & Replacement.....	33
Inner Door Removal, Inspection & Replacement.....	34
Resettable Thermal Switch Inspection & Replacement.....	37
ScreenLok® Flame Arrestor Cleaning.....	39
Glossary of Terms	39
Parts List.....	40
Notes.....	41

UPV Series

WARNING: If the information in these instructions is not followed exactly, a fire or explosion may result causing property damage, personal injury, or death.

FOR YOUR SAFETY

DO NOT store or use gasoline or other flammable, combustible, or corrosive vapors and liquids in the vicinity of this or any other appliance.

WHAT TO DO IF YOU SMELL GAS!

- Do not try to light any appliance.
- Do not touch any electrical switch; do not use any phone in your building.
- Immediately call your gas supplier from a neighbor's phone. Follow the gas supplier's instructions.
- If you cannot reach your gas supplier, call the fire department.

Installation and service must be performed by a qualified installer, service agency or the gas supplier.

⚠ WARNING

Water heaters are heat producing appliances. To avoid damage or injury, do not store materials against the water heater or vent-air intake system. Use proper care to avoid unnecessary contact (especially by children) with the water heater and vent-air intake components.

UNDER NO CIRCUMSTANCES MUST FLAMMABLE MATERIALS, SUCH AS GASOLINE OR PAINT THINNER BE USED OR STORED IN THE VICINITY OF THIS WATER HEATER, VENT-AIR INTAKE SYSTEM OR IN ANY LOCATION FROM WHICH FUMES COULD REACH THE WATER HEATER OR VENT-AIR INTAKE SYSTEM

⚠ WARNING

If sweat fittings are to be used **DO NOT** apply heat to the nipples on top of the water heater. Sweat the tubing to the adapter before fitting the adapter to the water connections. It is imperative that heat is not applied to the nipples containing a plastic liner.

⚠ WARNING

Hydrogen gas can be produced in an operating water heater that has not had water drawn from the tank for a long period of time (generally two weeks or more). **Hydrogen gas is extremely flammable.** To prevent the possibility of injury under these conditions, we recommend the hot water faucet to be open for several minutes at the kitchen sink before you use any electrical appliance which is connected to the hot water system. If hydrogen is present, there will be an unusual sound such as air escaping through the pipes as hot water begins to flow. **DO NOT** smoke or have open flame near the faucet at the time it is open.

⚠ DANGER

DO NOT store or use gasoline or other flammable, combustible, or corrosive vapors and liquids in the vicinity of this or any other appliance.

IMPORTANT

Before proceeding, please inspect the water heater and its components for possible damage. **DO NOT** install any water heater with damaged components. If damage is evident then please contact the supplier where the water heater was purchased, or the manufacturer listed on the rating plate for replacement parts.

⚠ WARNING

DO NOT ATTEMPT TO LIGHT ANY GAS APPLIANCE IF YOU ARE NOT CERTAIN OF THE FOLLOWING:

- Liquefied petroleum gases/propane gas and natural gas have an odorant added by the gas supplier that aids in the detection of the gas.
- Most people recognize this odor as a "sulfur" or "rotten egg" smell.
- Other conditions, such as "odorant fade" can cause the odorant to diminish in intensity, or "fade", and not be as readily detectable.
- If you have a diminished sense of smell or are in any way unsure of the presence of gas, immediately contact your gas supplier from a neighbor's telephone.

Gas detectors are available. Contact your gas supplier, or plumbing professional, for more information.

⚠ WARNING

FAILURE TO INSTALL AND MAINTAIN A NEW, LISTED 3/4" X 3/4" TEMPERATURE AND PRESSURE RELIEF VALVE WILL RELEASE THE MANUFACTURER FROM ANY CLAIM THAT MIGHT RESULT FROM EXCESSIVE TEMPERATURE AND PRESSURES.

⚠ WARNING

Turn OFF or disconnect the electrical power supply to the water heater before servicing. Label all wires prior to disconnection when servicing controls. Wiring errors can cause improper and dangerous operation. Verify proper operation after servicing.

Introduction

The new Bradford White URG1PV & URG2PV water heaters are designed to provide reliable performance with enhanced standard features. New design features include reliable spark to pilot ignition system, enhanced diagnostics, simplified servicing, significantly quieter operation, additional vent lengths, and Bradford White Defender Safety System® (not available on all models).

Spark to Pilot Ignition System - Employing the spark to pilot ignition system promotes reliable and consistent pilot and main burner ignitions to provide hot water on demand.

Integrated Immersion Thermostat/Gas Control Valve with LED - Developed for ease of troubleshooting by providing simple diagnostic codes to pinpoint an installation or component performance issue.

Powerful Blower - Will eliminate problems with difficult venting situations.

Quieter and Cooler Blower Operation - Blower noise is significantly reduced for both interior and exterior environments. Cooler operation increases blower life by reducing bearing wear and noise.

Concealed wiring connections - Provide simple error-free wiring.

Increased Vent Lengths - Increased venting performance is achieved while maintaining Energy Factor & FHR (not applicable on all models) performance.

The URG1PV & URG2PV water heaters use a combustion system where flue gases are combined with dilution air to reduce the flue gas temperature in the blower. The diluted flue gases are evacuated to the exterior through low temperature vent materials. The gas control maintains water temperature, ignition sequence and regulates gas flow. A safety circuit consisting of a pressure switch and blower temperature switch verifies proper conditions exist for safe and reliable operation. If a situation outside of normal operating parameters exists, the gas control diagnostic LED will flash a code to positively identify an operational issue.

This service manual is designed to facilitate problem diagnosis and enhance service efficiency. Please read the service manual completely before attempting service on this new series of power vent models.

How the Safety System Works

During normal operation, most air for combustion is drawn into the water heater through the openings in the jacket door. This air travels into the burner venturi, mixing with the gas jet. This air is then mixed with gas inside the burner and drawn to the burner screen and is efficiently combusted producing Ultra Low NOx emissions. Additional air is drawn through the openings in the jacket. This air travels down and around the combustion chamber and enters through holes in the bottom of the corrosion-resistant combustion chamber. The air then travels up through the oriented flame arrestor plate louvers, where they velocity of the air is increased, and its direction altered. The air then mixes in a normal manner with the combustion products from the burner.

In the case where trace amounts of flammable vapors are present in the air flowing into the combustion chamber and burner venturi, the vapors are harmlessly ignited by the burner/pilot flame. If flammable vapors are in sufficient quantity to prevent normal combustion, the burner and pilot flames are designed to shut down.

Should the flammable vapors continue to the burner, the flame arrestor plate and burner screen prevent the flames from traveling backwards and igniting vapors outside of the combustion chamber. The gas control utilizes a flammable vapor sensor to detect the presence of flammable vapors and shut down if the vapors achieve a certain level.

How to Use this Manual

It is intended for this manual to be used by qualified service personnel for the primary purpose of troubleshooting and repair of the Bradford White UPV Series water heaters. Understanding the sequence of operation section of this manual will contribute greatly to troubleshooting the water heater.

The Resideo WV4462A Electronic Gas Control will display status codes in the event of abnormal operation. Status codes are listed in the troubleshooting chart beginning on page 12 of this service manual. The troubleshooting chart will also indicate the probable cause for the status code and direct the service professional to a service procedure to properly diagnose the abnormal operation.

In some difficult to diagnose conditions, it may be necessary to isolate the heater from the vent system to determine the problem.

Contact Bradford White technical support immediately if diagnosis cannot be made using the methods described in this service manual.

Tools Required for Service

Manometer: A liquid "U" tube type or a digital (magnahelic) type can be used. This device is used to measure gas and/or air pressure and vacuum.

Multi-Meter: A digital type is strongly recommended. This device is used to measure electrical values. The meter you select must have the capability to measure volts AC, volts DC, Amps, micro-amps and ohms.

Electronic Probes: In some cases, standard multi-meter probes will damage or simply not be effective to obtain certain voltage and ohm readings. It will be necessary to have special electronic "pin" type multi-meter probes. These probes are available at most electronic wholesale outlets.

Thermometer: Used to measure water temperature. An accurate thermometer is recommended.

Water Pressure Gauge: Used to measure water supply pressure. Also used to determine tank pressure by adapting to the drain valve of the heater.

Various Hand Tools: Pipe wrench, channel locks, open end wrenches (3/8", 7/16", 1/2"), 12" crescent wrench, Allen wrench set, screwdrivers (common & Phillips & T20 Torx), 1/4" nut driver, pliers (common & needle nose), socket set, side cutters, wire cutters, wire strippers, wire crimpers, torpedo level, small shop vac, step ladder, flashlight and 5 gallon pail.

Specifications

Power Supply	Dedicated 115 VAC, 60 Hz, 15A
Gas Supply Pipe	Minimum 1/2" NPT (schedule 40 black iron pipe recommended)
Approved Gas Type	Natural gas, unit must match gas type supplied
Gas Pressure	6.0" W.C. min. for Natural Gas, 14.0" W.C. maximum
Venting System	Power vent through the wall or vertical through the roof
Approved Vent Materials	PVC, CPVC, or ABS
Minimum Clearance for Servicing	18" from top, 24" from front, 4" sides and rear
Water Supply Pressure	150 PSI maximum allowable working pressure. Check local codes for supply pressure.
Gas Control ECO Limit	Residential 188°F (87°C), Commercial 199°F (93°C)
Residential Temperature Set Point Range	60°F (16°C) to 160°F (71°C) (approximate temperatures)
Commercial Temperature Set Point Range	80°F (27°C) to 180°F (82°C) (approximate temperatures).
Blower Temperature Switch	URG(1,2)PV(40,50)T Models: Normally closed, opens @ 160°F (71°C), auto reset @ approximately 140°F (60°C) U(L,R)G2PV50H Models: Normally closed, opens @ 155°F (71°C), auto reset @ approximately 135°F (60°C)
Pressure Switch	URG(1,2)PV(40,50)(S,T) Models: Normally open, closes on vacuum increase @ -0.92" W.C.; Opens on vacuum decrease @ -0.87" W.C. U(L,R)G2PV50H Models: : Normally open, closes on vacuum increase @ -0.88" W.C.; Opens on vacuum decrease @ -0.83" W.C.
Blower	URG(1,2)PV(40,50)T Models: 115 VAC, 60 Hz, 3.3 amps, 3300 RPM U(L,R)G2PV50H Models: 115 VAC, 60 Hz, 3.3 amps, 3300 RPM

HIGH ALTITUDE INSTALLATIONS

This appliance has been certified for installations up to 10,100 ft above sea level without modification. Installations greater than 10,100 ft above sea level are not intended. Unauthorized modifications may result in unsafe operation.

WARNING: In order to assure the safe and efficient performance of the water heater, it is necessary to follow the vent connector length rules shown below. Failure to adhere to these rules can result in the unsafe operation of the appliance.

Vent Tables

Venting Specifications for:

URG1PV40S, URG2PV40T URG1PV50S, URG2PV50T

TABLE 1 - VENT CONNECTOR LENGTHS FOR 2 in (5.1 cm) DIAMETER VENT PIPE						
Terminating	# of Elbows (excl. vent terminals)	Minimum Straight Length ft (m)	Maximum Straight Length ft (m)			
			0-2000 (0-610)	2001-5400 (610-1646)	5401-7800 (1646-2378)	7801-10100 (2378-3079)
Elevation of installation above sea level ft (m)		0-10100 (0-3079)	0-2000 (0-610)	2001-5400 (610-1646)	5401-7800 (1646-2378)	7801-10100 (2378-3079)
Through the Wall	1	2 (0.6)	45 (13.7)	35 (10.7)	20 (6.1)	15 (4.6)
Through the Wall	2	2 (0.6)	40 (12.2)	30 (9.1)	15 (4.6)	10 (3.0)
Through the Wall	3	2 (0.6)	35 (10.7)	25 (7.6)	10 (3.0)	5 (1.5)
Through the Wall	4	2 (0.6)	30 (9.1)	20 (6.1)	5 (1.5)	NA
Through the Roof	0	7 (2.1)	50 (15.2)	40 (12.2)	25 (7.6)	20 (6.1)
Through the Roof	1	7 (2.1)	45 (13.7)	35 (10.7)	20 (6.1)	15 (4.6)
Through the Roof	2	7 (2.1)	40 (12.2)	30 (9.1)	15 (4.6)	10 (3.0)
Through the Roof	3	7 (2.1)	35 (10.7)	25 (7.6)	10 (3.0)	5 (1.5)

TABLE 2 – VENT CONNECTOR LENGTHS FOR 3 in (7.6 cm) DIAMETER VENT PIPE			
Terminating	# of Elbows (excl. vent terminals)	Minimum Straight Length ft (m)	Maximum Straight Length ft (m)
Through the Wall	1	10 (3.1)	115 (35.0)
Through the Wall	2	10 (3.1)	110 (33.5)
Through the Wall	3	10 (3.1)	105 (32.0)
Through the Wall	4	10 (3.1)	100 (30.5)
Through the Wall	5	10 (3.1)	95 (29.0)
Through the Roof	0	15 (4.6)	120 (36.6)
Through the Roof	1	15 (4.6)	115 (35.0)
Through the Roof	2	15 (4.6)	110 (33.5)
Through the Roof	3	15 (4.6)	105 (32.0)
Through the Roof	4	15 (4.6)	100 (30.5)

TABLE 3 – VENT CONNECTOR LENGTHS FOR 4 in (10.1 cm) DIAMETER VENT PIPE				
Terminating	# of Elbows (excl. vent terminals)	Minimum Straight Length ft (m)	Maximum Straight Length ft (m)	
			0-2000 (0-610)	2001-10100 (611-3079)
Elevation of installation above sea level ft (m)		0-10100 (0-3079)	0-2000 (0-610)	2001-10100 (611-3079)
Through the Wall	1	10 (3.1)	195 (59.4)	175 (53.3)
Through the Wall	2	10 (3.1)	190 (57.9)	170 (51.8)
Through the Wall	3	10 (3.1)	185 (56.4)	165 (50.3)
Through the Wall	4	10 (3.1)	180 (54.9)	160 (48.8)
Through the Wall	5	10 (3.1)	175 (53.3)	155 (47.2)
Through the Roof	0	15 (4.6)	200 (61.0)	180 (54.9)
Through the Roof	1	15 (4.6)	195 (59.4)	175 (53.3)
Through the Roof	2	15 (4.6)	190 (57.9)	170 (51.8)
Through the Roof	3	15 (4.6)	185 (56.4)	165 (50.3)
Through the Roof	4	15 (4.6)	180 (54.9)	160 (48.8)

Vent Tables

Venting Specifications for:

URG2PV50H, ULG2PV50H

TABLE 4 - VENT CONNECTOR LENGTHS FOR 3 in (7.6 cm) DIAMETER VENT PIPE						
Terminating	# of Elbows (excl. vent terminals)	Minimum Straight Length ft (m)	Maximum Straight Length ft (m)			
			0-2000 (0-610)	2001-5400 (610-1646)	5401-7800 (1646-2378)	7801-10100 (2378-3079)
Installation elevation above sea level ft (m)		0-10100 (0-3079)	0-2000 (0-610)	2001-5400 (610-1646)	5401-7800 (1646-2378)	7801-10100 (2378-3079)
Through the Wall	1	2 (0.6)	70 (21.3)	60 (18.3)	30 (9.1)	20 (6.1)
Through the Wall	2	2 (0.6)	65 (19.8)	55 (16.8)	25 (7.6)	15 (4.6)
Through the Wall	3	2 (0.6)	60 (18.2)	50 (15.2)	20 (6.1)	10 (3.0)
Through the Wall	4	2 (0.6)	55 (16.7)	45 (13.7)	15 (4.6)	5 (1.5)
Through the Roof	0	7 (2.1)	75 (22.8)	65 (19.8)	35 (10.7)	25 (7.6)
Through the Roof	1	7 (2.1)	70 (21.3)	60 (18.3)	30 (9.1)	20 (6.1)
Through the Roof	2	7 (2.1)	65 (19.8)	55 (16.8)	25 (7.6)	15 (4.6)
Through the Roof	3	7 (2.1)	60 (18.2)	50 (15.2)	20 (6.1)	10 (3.0)

TABLE 5 - VENT CONNECTOR LENGTHS FOR 4 in (10.2 cm) DIAMETER VENT PIPE					
Terminating	# of Elbows (excl. vent terminals)	Minimum Straight Length ft (m)	Maximum Straight Length ft (m)		
			0-5400 (0-1646)	5400-7800 (1646-2378)	7801-10100 (2378-3079)
Elevation of installation above sea level ft (m)		0-10100 (0-3079)	0-5400 (0-1646)	5400-7800 (1646-2378)	7801-10100 (2378-3079)
Through the Wall	1	10 (3.1)	175 (53.3)	160 (48.8)	105 (32.0)
Through the Wall	2	10 (3.1)	170 (51.8)	155 (47.2)	100 (30.5)
Through the Wall	3	10 (3.1)	165 (50.3)	150 (47.7)	95 (29.0)
Through the Wall	4	10 (3.1)	160 (48.8)	145 (44.2)	90 (27.4)
Through the Wall	5	10 (3.1)	155 (47.2)	140 (42.7)	85 (25.9)
Through the Roof	0	15 (4.6)	180 (54.9)	165 (50.3)	110 (33.5)
Through the Roof	1	15 (4.6)	175 (53.3)	160 (48.8)	105 (32.0)
Through the Roof	2	15 (4.6)	170 (51.8)	155 (47.2)	100 (30.5)
Through the Roof	3	15 (4.6)	165 (50.3)	150 (47.7)	95 (29.0)
Through the Roof	4	15 (4.6)	160 (48.8)	145 (44.2)	90 (27.4)

Control Timings

Ignition State	Timing
Pre-purge	15 seconds
Trial	90 seconds
Flame Stabilization Period	3 seconds
Inter-purge	15 seconds
Flame Failure Response Time	1.5 seconds (2 second maximum; 1 second minimum)
Post-purge	15 Seconds
PS Fault Delay (failed open/close)	Retry after 2 minutes
Soft Lockout	Retry after 5 minutes
ECO Limit Lockout	Indefinite (see page 26)
Verify Resistive Delay	Retry after 2 minutes (repeats 5 times)
Flammable Vapor Sensor/Simulated Resistive Load Lockout	Indefinite (cycle power to restart)
Hardware Status Lockout	Indefinite (self clears if fault clears for at least 15 seconds)

Wiring Diagram

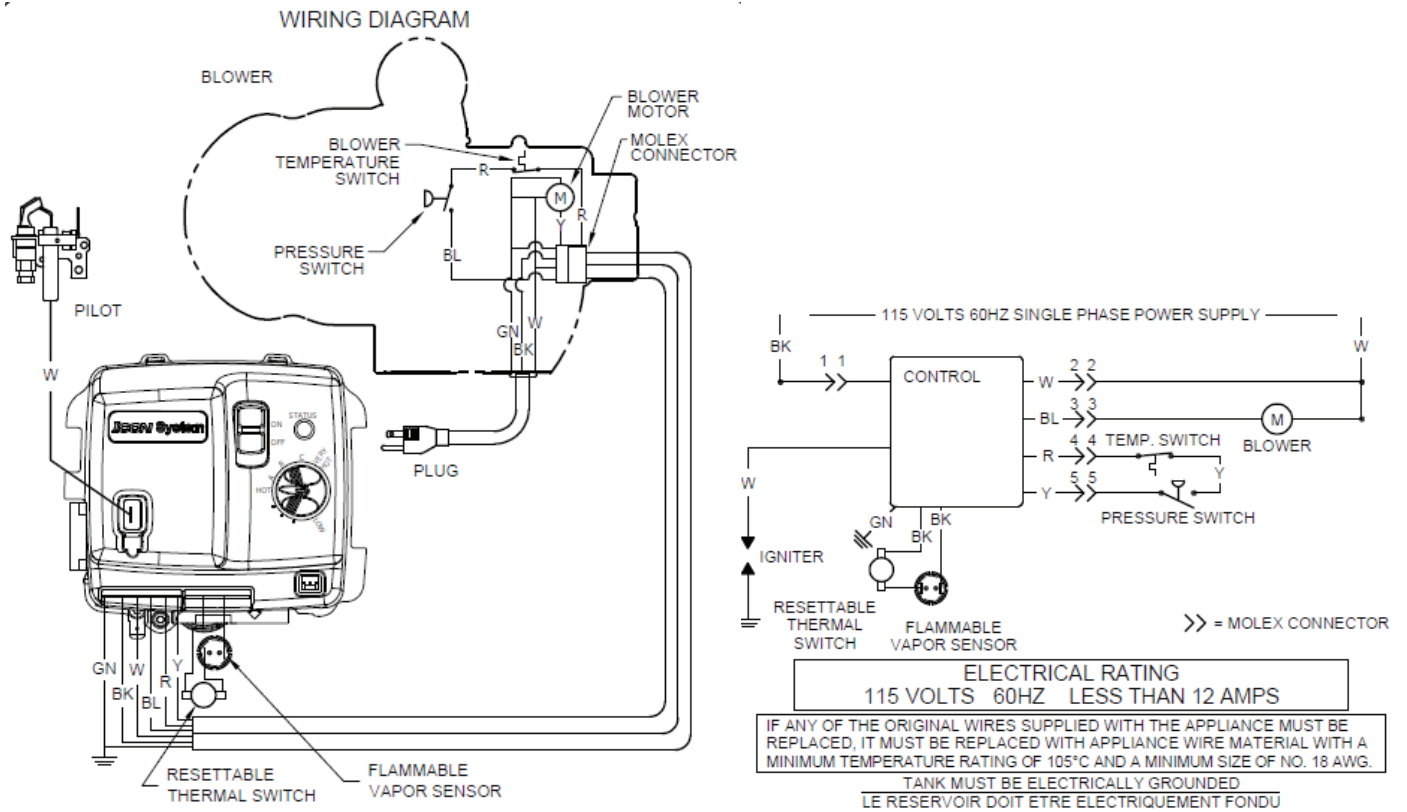

238-53849-00E

Sequence of Operations

Power Up Sequence

1. **Start Up:** Upon power up, the control runs a safe-start check with a typical start-up delay of 5 seconds.
2. **Flammable Vapor:** To assure no outputs are energized if the “Flammable Vapor Sensor” is out of range, the control will test the “Flammable Vapor Sensor” or “Simulated Resistive Device” for proper operating range. If the “Flammable Vapor Sensor” or “Simulative Resistive Device” is out of range, the control LED immediately flashes 7 times with a 3 second pause.

Normal Heating Sequence

1. Thermostat calls for heat: Prior to energizing blower, gas control checks safety circuit to ensure the circuit is open. Normal switch positions in the safety circuit are as follows:
 - a. Pressure switch normally open.
 - b. Blower temperature switch normally closed.If the safety circuit is closed, the control waits 4 seconds, gas control LED flashes 2 times with 3 second pause. Gas control waits 2 minutes then, blower runs for 30 seconds. This cycle repeats until safety circuit opens.
2. Blower energizes.
3. Pressure switch proves blower/vent system operation.
 - a. If the pressure switch does not close within 30 seconds, the control LED flashes 3 times with 3 second pause. The blower runs for 30 seconds every 2 minutes trying to get the pressure switch or blower temperature switch to close. This cycle repeats as long as there is a call for heat.
4. Blower pre-purge period (2 seconds).
5. Trial for pilot ignition (90 seconds).
 - a. The gas control lights the pilot by activating spark igniter and gas flow to pilot burner.
 - b. If flame is not sensed within 90 seconds, igniter and gas flow are deactivated, blower will post purge and control LED flashes 6 times with 3 second pause.
6. Main burner ignition: After pilot flame is sensed, gas control activates main valve for main burner ignition. The gas control will ignore flame and pressure switch signals for 3 seconds allowing for main burner to stabilize.
7. Steady state operation. During steady state operation, the control monitors:
 - a. **Thermostat temperature sensor** - When set point temperature is satisfied, gas valve is shut down and blower will post purge for 15 seconds. Control LED flashes a short flash once every 4 seconds (idle) status code.
 - b. **Pressure switch / blower temperature switch** - If either switch opens, pilot valve and main valve shut down. The blower continues to run for 30 seconds attempting to close the circuit. The control LED flashes 3 times with 3 second pause.
 - c. **Flame sensor** - If flame is lost, pilot and main valves are shut down, blower runs for 15 seconds. Control attempts to re-light pilot 4 times. If unsuccessful, blower is shut down and control proceeds to 5 minute lockout. Control re-attempts to light pilot starting at normal heating sequence #2.
8. Thermostat satisfies. (Control LED flashing once every 4 seconds).
9. Burner off.
10. Blower post purges (15 seconds).

Abnormal Operation

1. Flammable Vapor Sensor or Simulated Resistive Device Fault:
 - a. **If the resistance is greater than 70,000 Ohms**-the gas control immediately turns off all outputs. Control waits and monitors resistance for 30 seconds. If the resistance is greater than 65,000 ohms after 30 seconds, the gas control proceeds to verify resistive delay for 2 minutes and flashes 7 times then once with a three second pause. This process is repeated 5 times until the control either returns to normal operation or proceeds to flammable vapor lockout.
 - b. **If the resistance is below 3000 Ohms**-The gas control immediately turns off all outputs and proceeds to flash 8 times, then once with three second pause. The status self clears if the resistance returns to normal range for at least 15 seconds.
2. Temperature Sensor Fault:
 - a. **Temperature sensor detected open circuit** –The gas control immediately turns off all outputs and proceeds to flash 8 times then, 3 times with 3 second pause. The status self clears if the fault clears for at least 15 seconds.
 - b. **Thermal well sensor not reading the same temperature within $\pm 5.5^{\circ}\text{F}$** – The gas control immediately turns off all outputs and proceeds to flash 8 times, then 3 times twice with 3 second pause. The status self clears if the fault clears for at least 15 seconds.
 - c. **Water temperature in excess of ECO (energy cut out) limit** – The gas control immediately turns off pilot & main valves and proceeds to flash 4 times with 3 second pause. Blower continues to run until gas control is reset. To reset control, rotate knob of temperature control to the minimum setting for at least 6 seconds before returning to desired temperature setting.
3. Pressure Switch/Blower Temperature Fault:
 - a. **Pressure switch closed at start of call for heat**-the gas control waits 4 seconds then, proceeds to flash 2 times with 3 second pause. The control waits 2 minutes and then turns on blower for 30 seconds. The blower turns off after 30 seconds and the control waits for pressure switch to open. Any time the pressure switch opens, the blower turns on (or stays on) and the control proceeds to wait for pressure switch to close.
 - b. **Pressure switch or blower temperature switch failed to close**-the gas control runs the blower for 30 seconds waiting for the pressure switch and/or blower temperature switch to close. If either switch does not close in 30 seconds, the blower turns off and the control flashes 3 times with 3 second pause. The gas control waits 2 minutes before turning on the blower for another 30 seconds to see the circuit close. This cycle repeats as long as there is a call for heat or until the circuit closes.
 - c. **Pressure switch or blower temperature switch opens during burner operation**-the gas control turns off the pilot and main valve, runs blower for 15 seconds (inter-purge) waiting for pressure switch and/or blower temperature switch to close. If either switch fails to close, the control proceeds as described in 3b above, if the circuit closes again by the end of the inter-purge, the recycle counter is incremented, if the recycle count has not reached its limit (4), another trial for ignition begins. If the recycle count has been reached, the gas control turns off the blower and flashes 6 times then, 2 times with 3 second pause. The gas control waits 5 minutes before repeating ignition sequence.
4. Trial for Ignition Fault:
 - a. **Pressure switch opens during trial**-the gas control turns off igniter and pilot valve. The gas control proceeds as described in 3b above. If the pressure switch closes within 30 seconds the gas control will continue with trial for ignition starting at blower pre-purge.
 - b. **Flame not sensed**-the gas control energizes the spark igniter attempting to light the pilot and prove flame. If flame is not sensed within 90 seconds, the igniter turns off, the pilot valve is closed, and the gas control runs the blower through post purge and flashes 6 times then, once with 3 second pause. The control waits 5 minutes before repeating the ignition sequence.
5. Flame sensing fault:
 - a. **Flame lost during run**-the gas control turns off pilot and main valves, runs blower for 15 seconds (inter-purge). The gas control increments the recycle count, if the recycle count has not reached its limit (4), another trial for ignition begins. If the recycle count has been reached, the gas control turns off the blower and flashes 6 times then, 3 times with 3 second pause. The gas control waits 5 minutes before repeating the ignition sequence.
 - b. **Flame sensed out of sequence**-the gas control only looks for pilot flame when the blower is running. If flame is present when the pilot valve is not open, the gas control proceeds to wait for flame loss and flashes 5 times with 3 second pause. This continues until flame is lost. Once the flame signal is lost, the control flashes 6 times then, 4 times with 3 second pause. The control waits 5 minutes before repeating the ignition sequence.

Troubleshooting

Observe green LED indicator on electronic gas control. Status flash codes are displayed with a three second pause before repeating. Check and repair the system as noted in the troubleshooting table below.

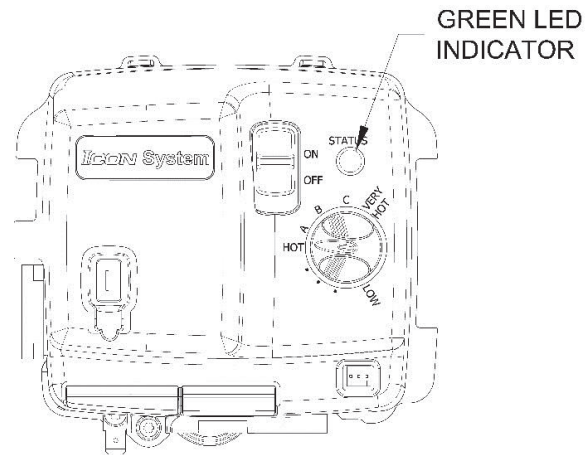

LED Status	Control Status	Probable Cause	Service Procedure
None, control LED not on or flashing	No electrical power	Control power switch in "OFF" position. Supply voltage interrupted.	Turn power on.
Short flash, once every four seconds	Stand-by mode, waiting for call for heat (no fault).	Temperature demand is satisfied.	Normal operation. Adjust thermostat to temp level.
Alternates bright/dim (heartbeat)	Thermostat calling for heat (no fault).	Tank temperature below set point of thermostat.	Normal operation. Adjust thermostat to temp level.
Short flash once per second	Weak pilot signal on last call for heat.	<ol style="list-style-type: none"> 1. Unstable pilot. 2. Pilot tube block or restricted. 3. Oxidation build up on pilot electrode. 4. Wire damage to pilot assembly or bad connection at gas valve. 	Page 16.
Two flash, three second pause	Pressure switch not working- closed position.	<ol style="list-style-type: none"> 1. Pressure switch tubing kinked or blocked. 2. Blocked pressure tap on switch or blower. 3. Faulty pressure switch. 	Page 17.
Three flash, three second pause	Pressure switch or blower temp. switch not working -open position.	<ol style="list-style-type: none"> 1. Vent blockage or improper vent configuration. 2. Pressure switch tubing kinked or blocked. 3. Faulty pressure switch. 4. Blower not spinning up to speed. 5. Blower temp or exhaust temp too high. 6. Faulty blower temperature switch. 	<ol style="list-style-type: none"> 1. Check vent or vent tables. 2 & 3. Page 17. 4. Page 19. 5 & 6. Page 23.
Four flash, three second pause	Excessive tank temperature. System must be reset.	<ol style="list-style-type: none"> 1. Temperature sensor out of calibration. 2. Faulty gas control. 3. Plumbing leak. 	1 & 2. Replace gas control, page 27.
Five flash, three second pause	Undesired-false pilot flame present.	<ol style="list-style-type: none"> 1. Pilot valve stuck in open position. 	Replace gas control, page 27.

LED Status	Control Status	Probable Cause	Service Procedure
Six-one flash, three second pause	Failed to light pilot. System auto resets.	<ol style="list-style-type: none"> 1. Unstable pilot. 2. Pilot tube blocked or restricted. 3. Oxidation build up on pilot electrode. 4. Wire damage to pilot assembly or bad connection at gas valve. 	Page 16.
Six-two flash, three second pause	Pressure switch or blower temp switch opened during burner operation. System auto resets.	<ol style="list-style-type: none"> 1. Vent blockage or improper vent configuration. 2. Pressure switch tubing kinked or blocked. 3. Faulty pressure switch. 4. Vent termination being affected by wind. 5. Blower not spinning up to speed. 6. Blower temp or exhaust temp too high. 7. Faulty blower temperature switch. 	<ol style="list-style-type: none"> 1. Check vent or vent tables. 2 & 3 Page 18. 4. Refer to venting section of installation manual. 5. Page 19. 6 & 7. Page 23.
Six-three flash, three second pause	Pilot flame extinguished. System auto resets.	<ol style="list-style-type: none"> 1. Unstable pilot. 2. Pilot tube blocked or restricted. 3. Oxidation build up on pilot electrode. 4. Wire damage to pilot assembly or a bad connection at gas valve. 5. Insufficient combustion air. 6. Gas pressure is out of specification. 	<ol style="list-style-type: none"> 1-4. Page 16. 5. Refer to installation manual. 6. Page 27.
Six-four flash, three second pause	Undesired-false pilot flame sensed. System auto resets.	Pilot valve stuck in open position.	Replace gas control, page 27.
Seven flash, three second pause	Flammable vapor sensor or resettable thermal switch fault detected.	<ol style="list-style-type: none"> 1. Flammable vapor present 2. Flammable vapor sensor exposed to excessive moisture 3. Flammable vapor sensor exposed to extreme ambient temperature 4. Resettable thermal switch open 	<ol style="list-style-type: none"> 1-3. Flammable sensor testing, page 28. 4. Resettable thermal switch testing, page 37.
Eight-one flash, three second pause.	Flammable vapor sensor out of specification.	Flammable vapor sensor or simulated resistive device out of specification.	Page 28.
Eight-two flash, three second pause.	Temperature sensor fault.	<ol style="list-style-type: none"> 1. Damage to temperature sensor wire. 2. Temperature sensor resistance out of range. 	Replace gas control, page 27.
Eight-three flash, three second pause.	Gas valve electronics fault detected.	<ol style="list-style-type: none"> 1. Control needs to be reset. 2. Control is wet or physically damaged. 	<ol style="list-style-type: none"> 1. Interrupt power supply. 2. Replace gas control, page 27.
Eight-four flash, three second pause.	Gas valve fault detected.	<ol style="list-style-type: none"> 1. Control needs to be reset. 2. Control is wet or physically damaged. 	<ol style="list-style-type: none"> 1. Interrupt power supply. 2. Replace gas control, page 27.

UPV Service Procedure I – Burner Operation Inspection, Cleaning, and Replacement

Burner Inspection

At periodic intervals (every 6 months) a visual inspection should be made of the pilot and main burner for proper operation and to assure no debris is accumulating.

Pilot flame should be stable, some causes for an unstable pilot flame are:

- a. Water heater vent is less than the allowable vent length.
- b. Gas pressure is out of specification.
- c. Pilot flame not fully engulfing spark/flame sensor.

Main burner should light smoothly from pilot and burn with a blue flame with a minimum of yellow tips. Main burner must be free from any debris accumulation that may affect burner operation.

Burner Cleaning

- Step 1. Position the gas control power switch to the "OFF" position and unplug the heater from the wall outlet.
- Step 2. Turn OFF gas supply to the water heater.
- Step 3. Remove outer jacket door.
- Step 4. Disconnect pilot tube (7/16" wrench) and feedline (3/4" wrench) from gas control.
- Step 5. Disconnect igniter/flame sensor wire from gas control.
- Step 6. Remove the (4) 1/4" hex drive screws holding the right side inner door in place.
- Step 7. Remove the (3) 1/4" hex drive screws holding the left side burner door in place.
- Step 8. Remove burner assembly from combustion chamber.

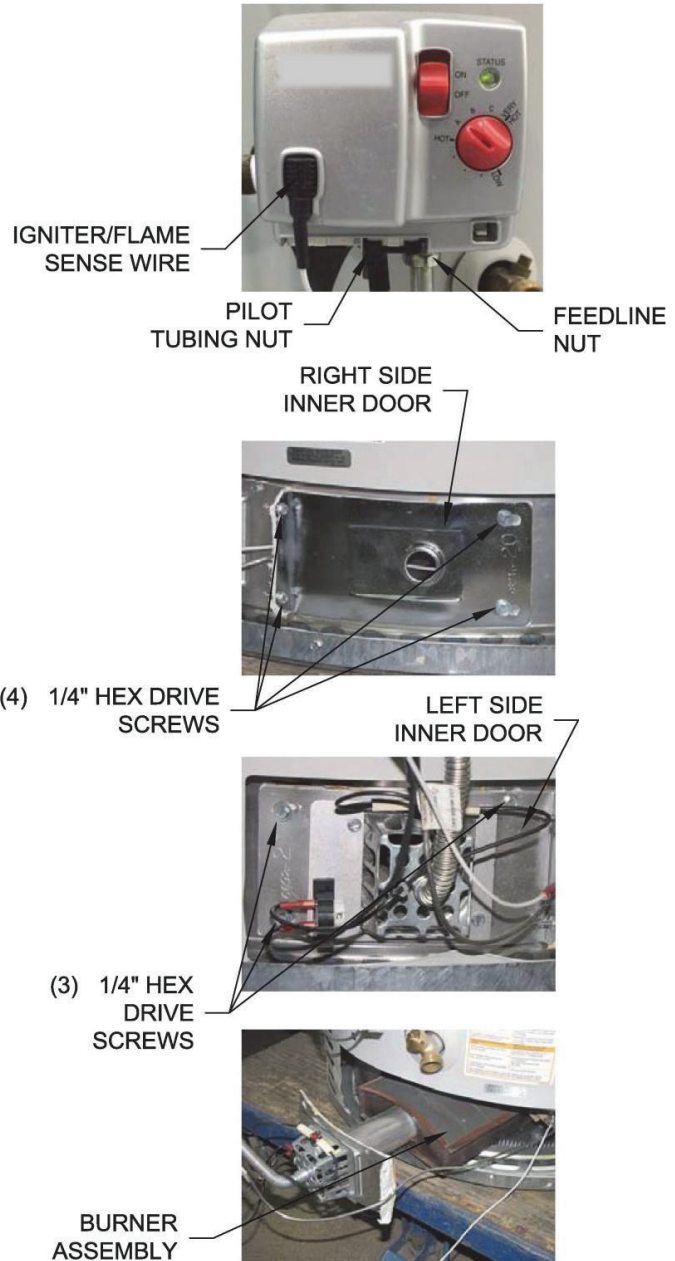

Burner Cleaning cont.-

- Step 9. Remove manifold mount from burner inner door by removing (2) 1/4" hex drive screws.
- Step 10. Use a stiff brush, compressed air and/or a vacuum to remove any debris build up from the manifold mount.
- Step 11. Thoroughly inspect burner surface area and burner port area and remove any loose debris using compressed air and/or a vacuum.
- Step 12. Thoroughly inspect burner screen and burner venturi and remove any loose debris accumulation. Inspect burner screen for any openings larger than the normal screen openings.
- Step 13. Remove main burner orifice from feedline (1/2" wrench) inspect orifice, clean or replace if necessary.
- Step 14. Reassemble burner and reinstall inner door with gasket into water heater per Service Procedure XIV on page 35. Restore gas supply and check for gas leaks.
- Step 15. To resume operation, follow the instruction located on the lighting instruction label or the lighting instruction located in the Installation and Operation Manual.

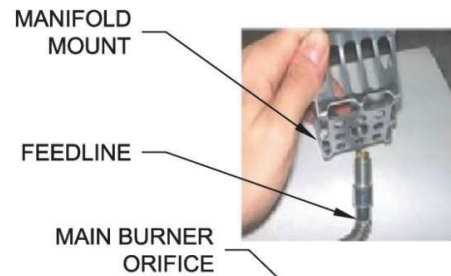
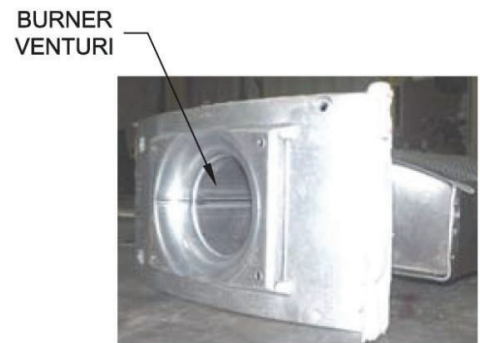
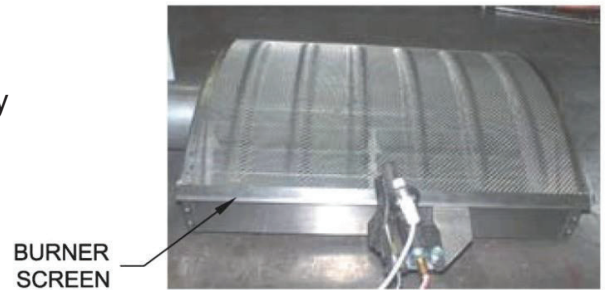
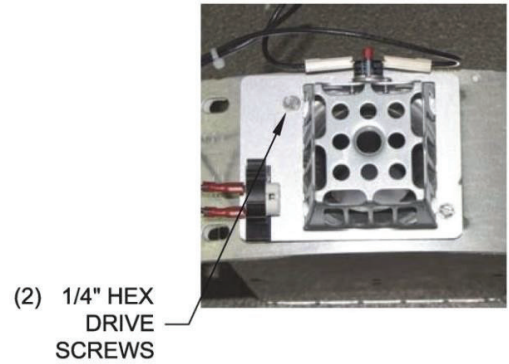

Pilot Inspection, Testing, and Replacement

- Step 1. Visually inspect igniter/flame sense electrode for oxidation build up. Carefully clean any oxidation using very fine emery cloth.
- Step 2. Remove pilot assembly from the burner assembly ($\frac{1}{4}$ " nut driver).
- Step 3. Visually inspect igniter/flame sense wire for damage. Replace pilot if damage is found.
- Step 4. With a multi-meter set to ohms setting, check continuity through igniter/flame sense wire. Replace pilot if no continuity.
- Step 5. Visually inspect igniter/flame sense electrode for deterioration. Replace pilot as necessary. Electrode should not be in contact with pilot hood, if so, carefully adjust electrode to a gap of distance of $\frac{3}{32}$ " (.09) from pilot hood.
- Step 6. Visually inspect pilot tubing for kinks or cracks. If damage is found, replace pilot.
- Step 7. Inspect pilot tubing and pilot orifice for blockage:
 - a. Remove ferrule nut from bottom of pilot assembly ($\frac{7}{16}$ " wrench).
 - b. Remove pilot tube and pilot orifice.
 - c. Inspect pilot tubing and pilot orifice for blockage. Clean or replace as necessary.
- Step 8. Reassemble pilot and install on burner. Reinstall burner assembly to water heater per Service Procedure XIV.
- Step 9. Restore gas supply and check for gas leaks.
- Step 10. To resume operation, follow the instruction located on the lighting instruction label or the lighting instruction located in the installation and operation manual.

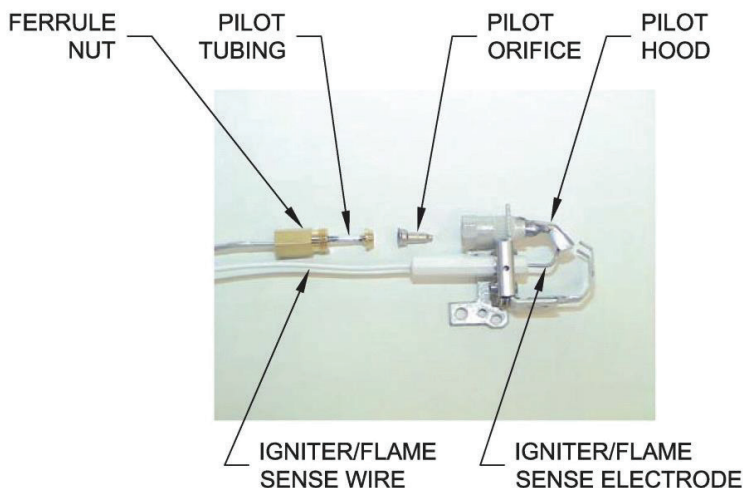
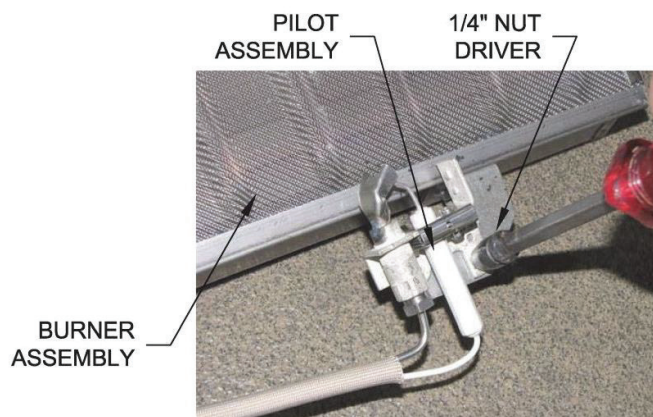

UPV Service Procedure III – Pressure Switch Testing and Replacement

Pressure Switch Testing

⚠ WARNING

**115 volt potential exposure.
Use caution to avoid personal injury.**

- Step 1. Position power switch on gas control to the "OFF" position.
- Step 2. Remove the three screws (T20 Torx driver) from control access cover on blower assembly and remove cover (see photo 1).
- Step 3. Carefully remove pressure switch from blower housing (see photo 2).

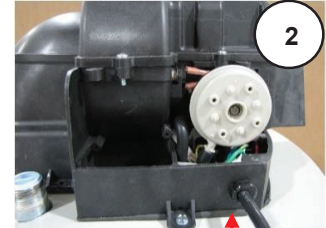

Pressure switch wire leads

Slide pressure switch in direction of arrow while tilting slightly away from blower housing.

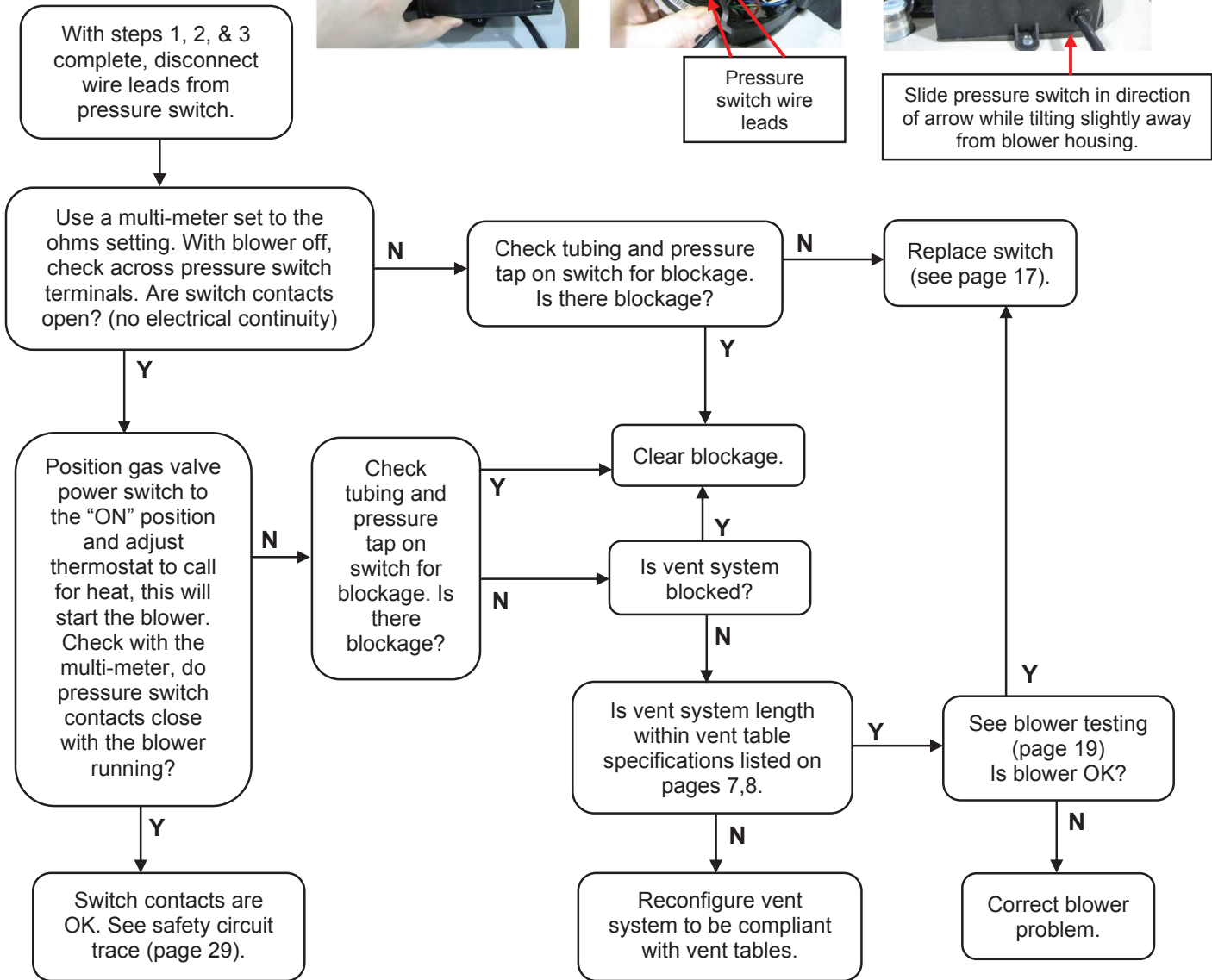

UPV Service Procedure III – Pressure Switch Testing and Replacement

Pressure Switch Replacement

- Step 1. Position gas control power switch to “OFF” position.
- Step 2. Remove the three screws (T20 Torx driver) from control access cover on blower assembly and remove cover (see photo 3).
- Step 3. Carefully remove pressure switch from blower housing (see photo 4).
- Step 4. Disconnect tubing from pressure switch (see photo 5).
- Step 5. Disconnect red wires from pressure switch (see photo 6).
- Step 6. Reconnect wires from step 5 to new pressure switch.
- Step 7. Reconnect tubing to new pressure switch.
- Step 8. Carefully position pressure switch into blower housing.
- Step 9. Position gas control power switch to “ON” position and verify proper heater operation.
- Step 10. Replace control access cover from step 2.

⚠ WARNING
115 volt potential exposure.
Use caution to avoid personal injury.

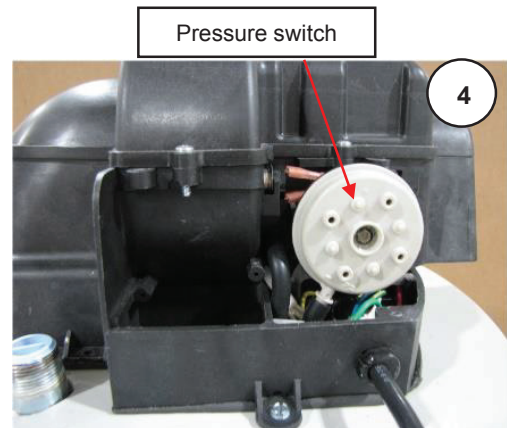
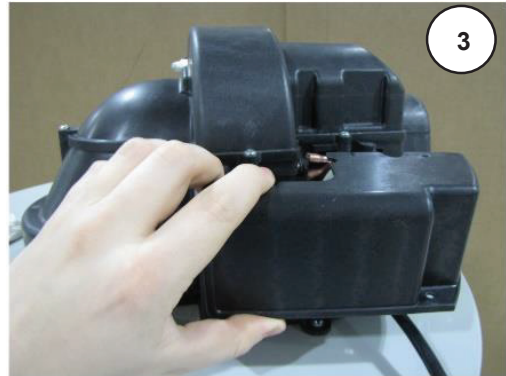

Slide pressure switch in direction of arrow while tilting slightly away from blower housing.

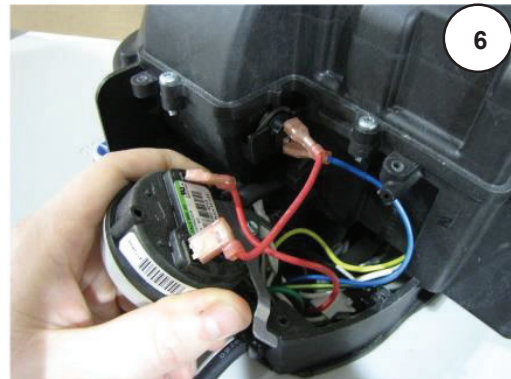
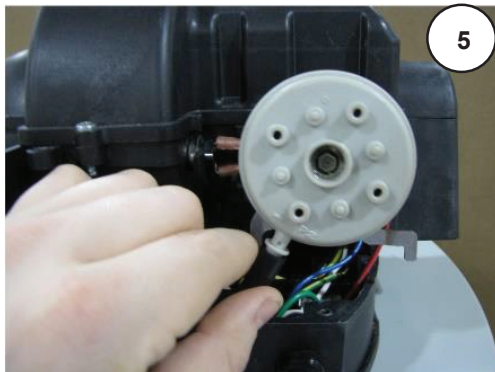

UPV Service Procedure IV – Blower Testing and Replacement

Blower Testing

Step 1. Position gas control power switch to “ON” position and adjust control to call for heat.

Step 2. Remove the three screws (T20 Torx driver) from control access cover on blower assembly and remove cover (see photo 7).

⚠ WARNING
115 volt potential exposure.
Use caution to avoid personal injury.

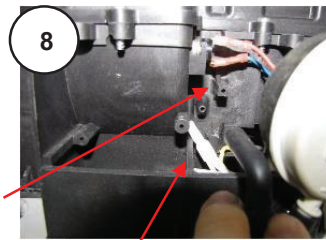
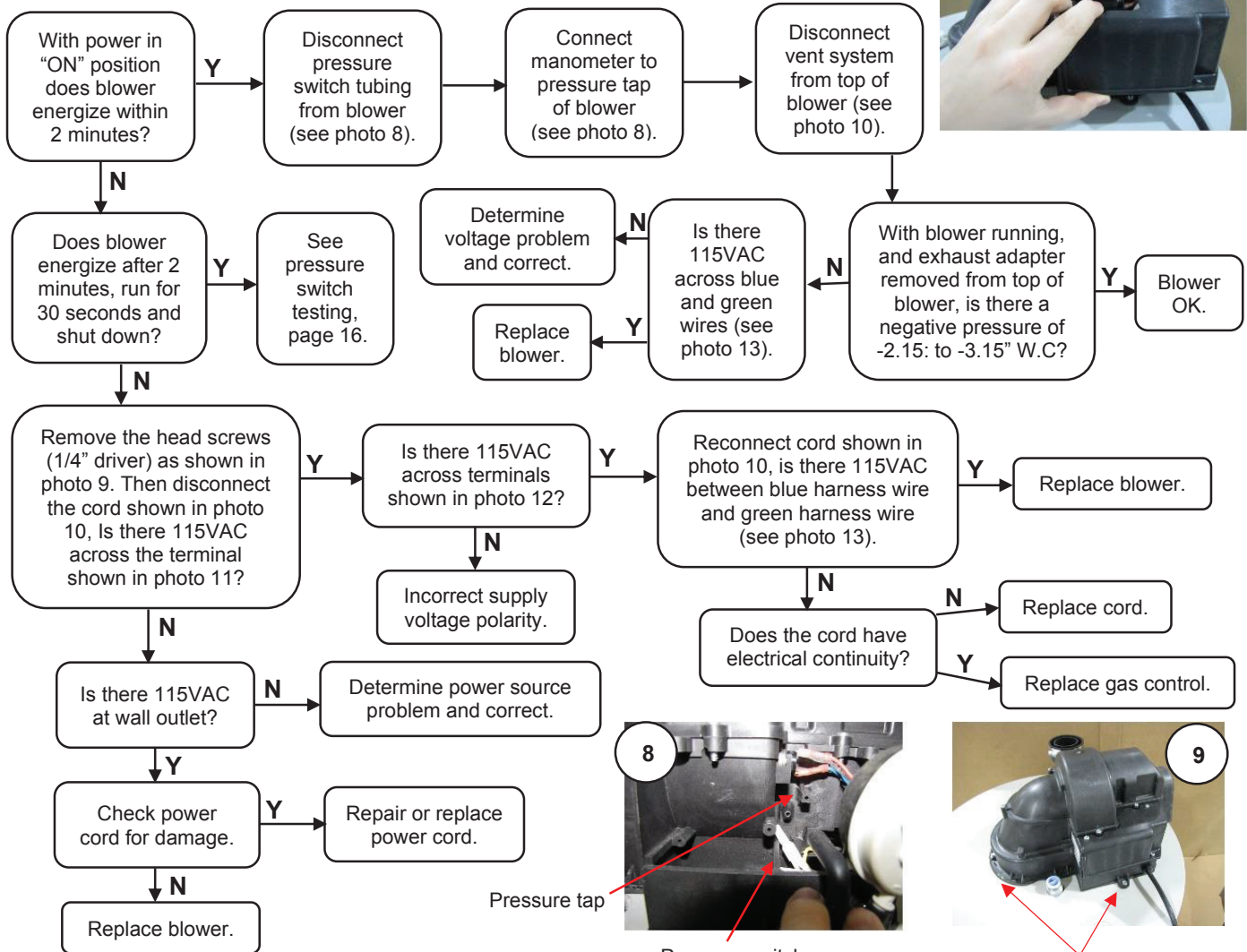

Pressure tap

Pressure switch tubing



Blower mounting screws

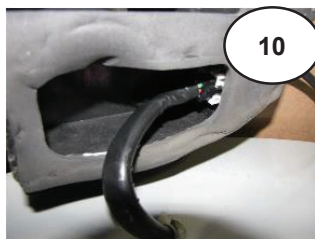

10

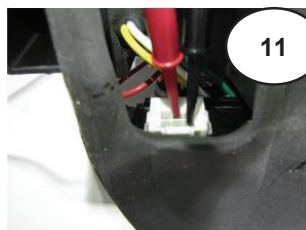

11

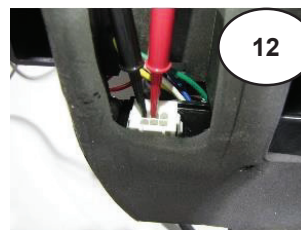

12

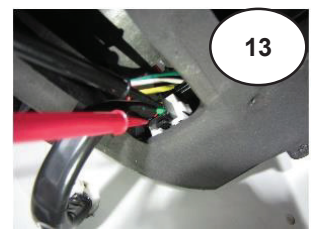

13

UPV Service Procedure IV – Blower Testing and Replacement

Blower Removal

- Step 1. Position gas control power switch to “OFF” position.
- Step 2. Unplug blower power cord from wall outlet.
- Step 3. Disconnect vent system from exhaust adapter on top of blower.
- Step 4. Remove the three blower mounting screws (1/4” nut driver).
- Step 5. Unplug cord from blower (see picture at right).
- Step 6. Remove blower with gasket from water heater.



Blower mounting screws

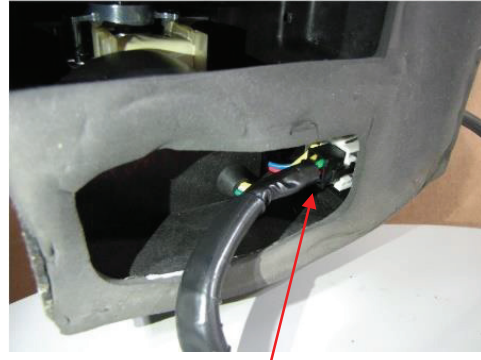

Blower power cord

Blower Installation

- Step 1. Clean any debris from jacket head of water heater.
- Step 2. Reconnect cord set from Blower Removal Step 5.
- Step 3. Set new blower with gasket in place using locating pins on blower flange to line up with location holes in jacket head. Be sure not to damage gasket.
- Step 4. Secure blower in place using mounting screws from Blower Removal Step 4.
- Step 5. Reconnect vent system to the blower.
- Step 6. Plug blower power cord into wall outlet.
- Step 7. Position gas control power switch to the “ON” position.
- Step 8. Verify proper blower operation.

Locating pins on blower flange



Pin location holes in jacket head

UPV Service Procedure V – Replacement Wire Harness Installation

Replacement Wire Harness Installation

1. Remove the blower assembly from the heater according to the steps outlined in Blower Removal.
2. On the back of the blower assembly, using a 3/4" bit, drill a hole through exterior molded wall. Be very careful not to drill through the interior molded wall. Drilling through the interior molded wall will require the blower to be replaced (below).

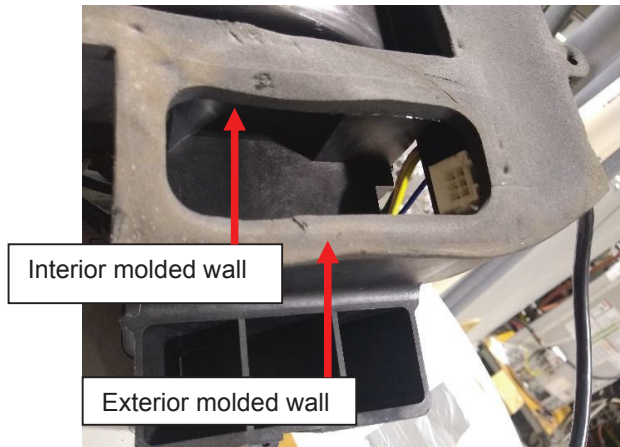

Drill through the exterior molded wall without damaging the interior molded wall at the location shown (right).

3. Clean any debris from the jacket and jacket head of the water heater.
4. Insert the external wire harness through the drilled hole.
5. Plug the wire harness into the molex connector inside the blower assembly housing. Ensure the connection is clean and seated properly (below).



External Wire Harness Installation continued-

- 6. Install the blower assembly according to the steps outlined in Blower Removal.



UPV Service Procedure VI – Blower Temperature Switch Testing and Replacement

Blower Temperature Switch Testing

- Step 1. Position power switch on gas control to the “OFF” position.
- Step 2. Remove the three screws (T20 Torx driver) from control access cover on blower and remove cover (see photo 14).
- Step 3. Locate blower temperature switch (see photo 15).

⚠ WARNING

**115 volt potential exposure.
Use caution to avoid personal injury.**

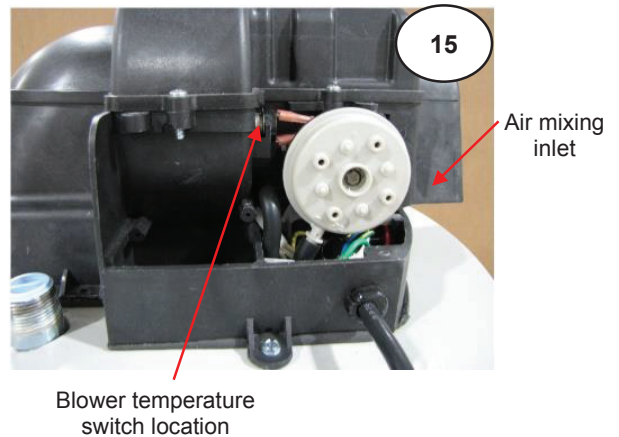
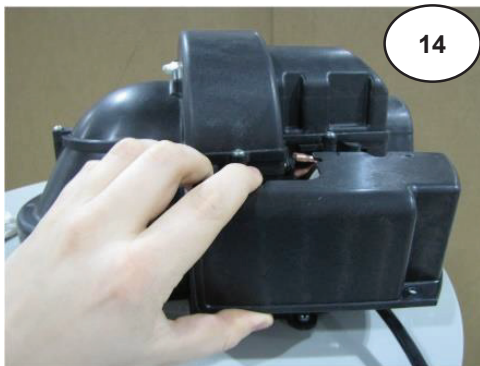
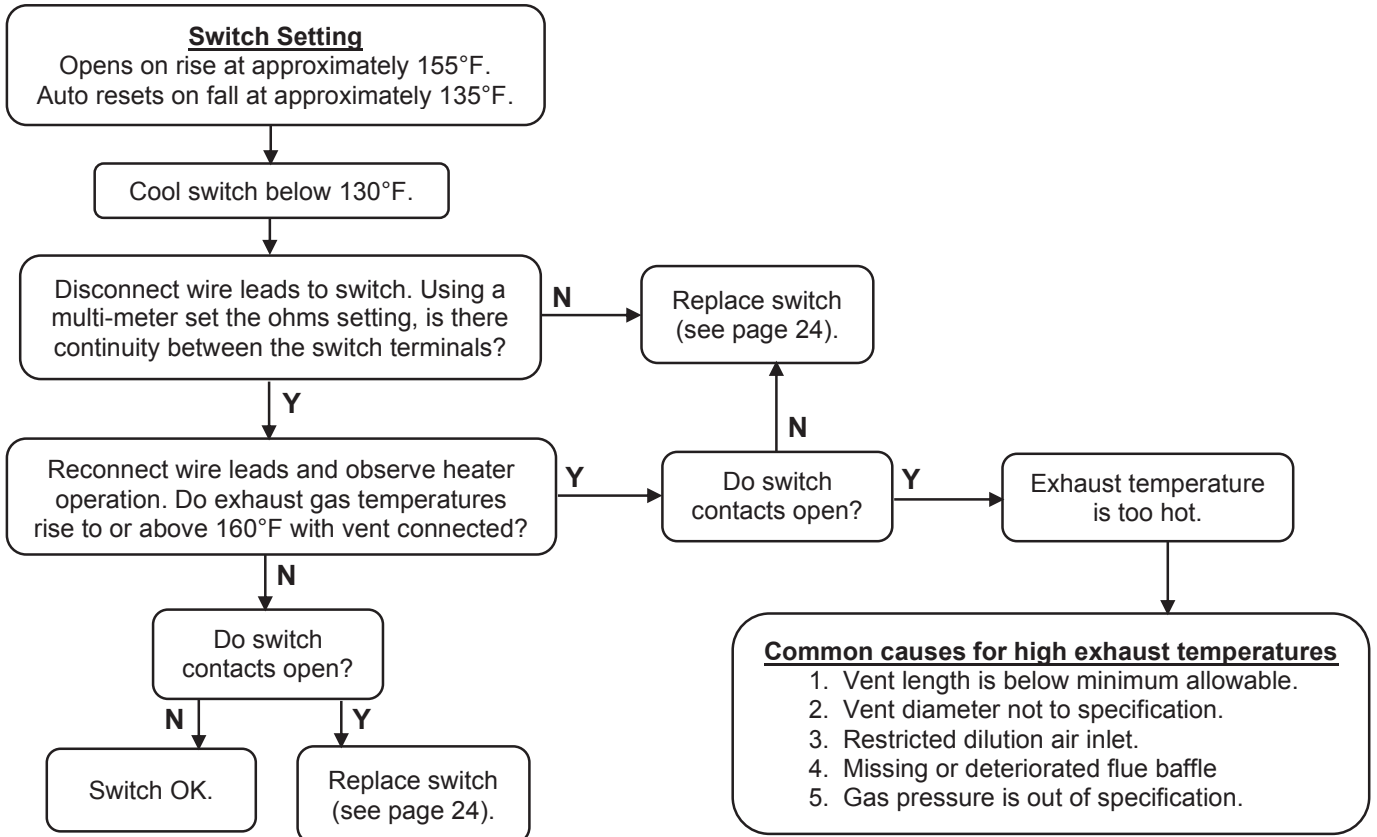

UPV Service Procedure VI – Blower Temperature Switch Testing and Replacement

Blower Temperature Switch Replacement

⚠ WARNING
115 volt potential exposure.
Use caution to avoid personal injury.

- Step 1. Position gas control power switch to the “OFF” position and unplug heater from wall outlet.
- Step 2. Remove the three screws (T20 Torx driver) from the control access cover on blower and remove cover (see photo 16).
- Step 3. Locate blower temperature switch (see photo 17).
- Step 4. Disconnect red and blue wire leads from switch.
- Step 5. Remove the seven T20 Torx screws from the blower top (photo 18). Then remove the top of the blower (photo 19).
- Step 6. Remove switch from blower housing.
- Step 7. Install new switch. Be sure switch is properly seated in mounting area.
- Step 8. Reconnect red and blue wires to new switch. Wires are interchangeable with either terminal.
- Step 9. Reinstall the blower top and all seven T20 Torx screws.
- Step 10. Position gas control power switch to the “ON” position and verify proper heater operation.
- Step 11. Replace control access cover from step 2.

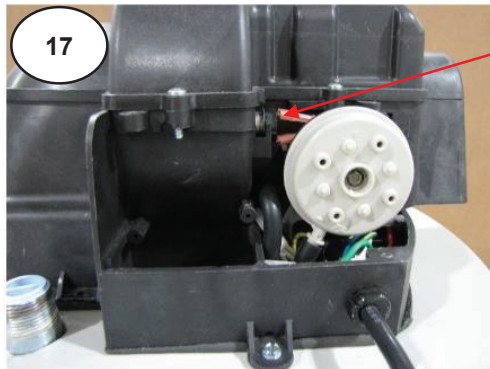
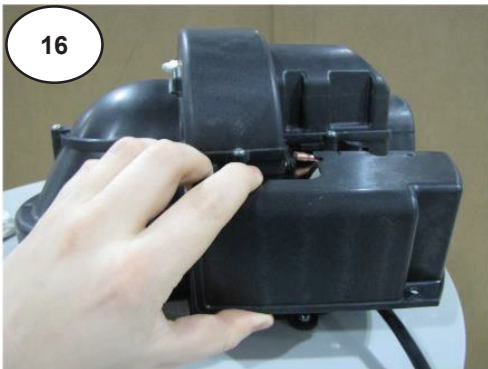

Blower temperature switch location

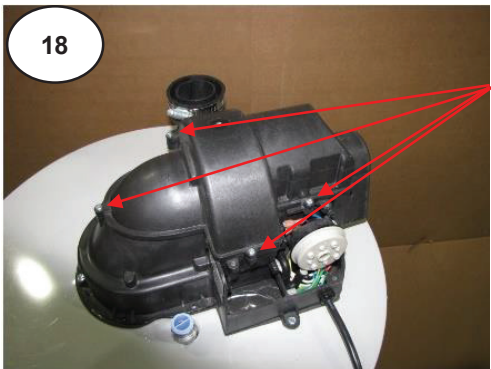

7 T20 Torx screws



UPV Service Procedure VII – Gas Control Testing and Replacement

Line Pressure

The gas control is designed for a maximum line pressure of 14.0" W.C. and a minimum line pressure of 1.0" W.C. over the water heater's rated manifold pressure (check rating plate). Line pressure must be checked with the main burner on **and** off to assure proper readings.

Manifold Pressure Testing

(This procedure presumes a maximum line pressure of 14.0" W.C.)

- Step 1. Set the gas control to the "OFF" position.
- Step 2. Remove pressure tap plug (3/16" Allen wrench) and install 1/8" NPT pipe, coupling, and pressure tap.
- Step 3. Connect manometer to pressure tap.
- Step 4. Follow instructions located on the lighting instructions label and proceed to light the main burner and observe manometer reading.
- Step 5. Proper operating range for natural gas is 5.0" \pm 0.5" W.C.
- Step 6. If pressure is within the range specified in the previous step, set gas control knob to the "OFF" position, remove manometer and pressure tap, and replace pressure tap plug. Check for gas leaks prior to placing water heater back into operation by following the instructions located on the lighting label, or the lighting instructions located in the installation and operation manual.
- Step 7. If gas pressure is outside the specification noted above.

GAS CONTROL SHOWN IN THE "OFF" POSITION



3/16" ALLEN WRENCH

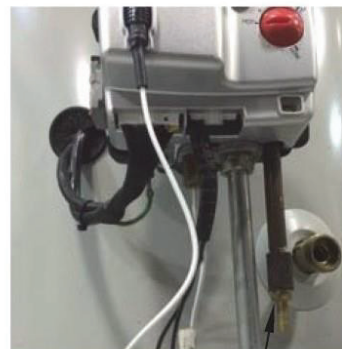

PRESSURE TAP SHOWN INSTALLED

UPV Service Procedure VII – Gas Control Testing and Replacement

ECO (Energy Cut Out) Testing

The Resideo gas control is designed with an ECO device that will reset.

To reset the gas control after a status code (4), turn the gas control knob to the “OFF” position and wait a minimum of (5) minutes before relighting following the instructions located on the lighting instruction label or the lighting instructions located in the installation and operation manual.

WARNING

**115 volt potential exposure.
Use caution to avoid personal injury.**

Determine Water Temperature Inside Tank

WARNING

Stored water may be HOT when performing the following steps in this procedure. Take necessary precaution to prevent personal injury.

- Step 1. Position gas control power switch to “OFF” position.
- Step 2. Draw approximately 4 gallons of water from drain valve into a container and discard. Draw an additional gallon and immediately measure water temperature using an accurate thermometer (It may be necessary to open a hot water faucet to allow heater to drain).
- Step 3. Compare the measured water temperature with the setting on the gas control. In most instances, they should not differ by more than approx. 10°F.

UPV Service Procedure VII – Gas Control Testing and Replacement

Gas Control Removal from Water Heater

- Step 1. Position gas control power switch to the “OFF” position and unplug the water heater from power supply.
- Step 2. Drain the water heater to a point below the gas control level.
- Step 3. Turn OFF gas supply to water heater and disconnect gas piping from gas control.
- Step 4. Disconnect the wire harnesses from gas control.
- Step 5. Remove the outer jacket burner access door.
- Step 6. Disconnect the main burner feedline, swing counter-clockwise away from the gas control.
- Step 7. Disconnect the pilot tube from gas control and move away from gas control.
- Step 8. Remove the gas control from the water heater by rotating counter-clockwise. DO NOT use a wrench on the gas control body, damage to the gas control may occur. If necessary, use a length of ½” NPT pipe threaded into gas inlet of gas control.

⚠ WARNING
115 volt potential exposure.
Use caution to avoid personal injury.

GAS CONTROL SHOWN IN THE "OFF" POSITION



MAIN BURNER FLEXIBLE FEEDLINE PILOT FEEDLINE

Gas Control Installation Into Water Heater

- Step 1. Install new gas control into water heater by rotating clockwise. DO NOT use a wrench on the gas control body, damage to the gas control may occur. If necessary, use a length of ½” NPT pipe threaded into gas inlet of gas control.
- Step 2. Reattach main burner feedline, pilot tube and thermopile wire.
- Step 3. Reconnect gas supply piping to inlet of gas control and check for leaks.
- Step 4. To resume operation, follow the instructions located on the lighting instruction label or the lighting instructions located in the Installation and Operation Manual.

UPV Service Procedure VIII – Flammable Vapor/Simulative Resistance Device Testing

Flammable Vapor Sensor Testing

- Step 1. Position power switch on gas control to the "OFF" position.
- Step 2. Disconnect flammable vapor sensor from gas control.
- Step 3. Using a multi-meter set to the ohms setting, check resistance of flammable vapor sensor. Resistance must be within 3,000 ohms and 48,000 ohms. If outside of this range replace Flammable Vapor Sensor.

⚠ WARNING
DO NOT use a standard multi-meter probe for this test. Doing so will damage connector. Use special pin type electronic probes or small diameter wire pins inserted into connector.

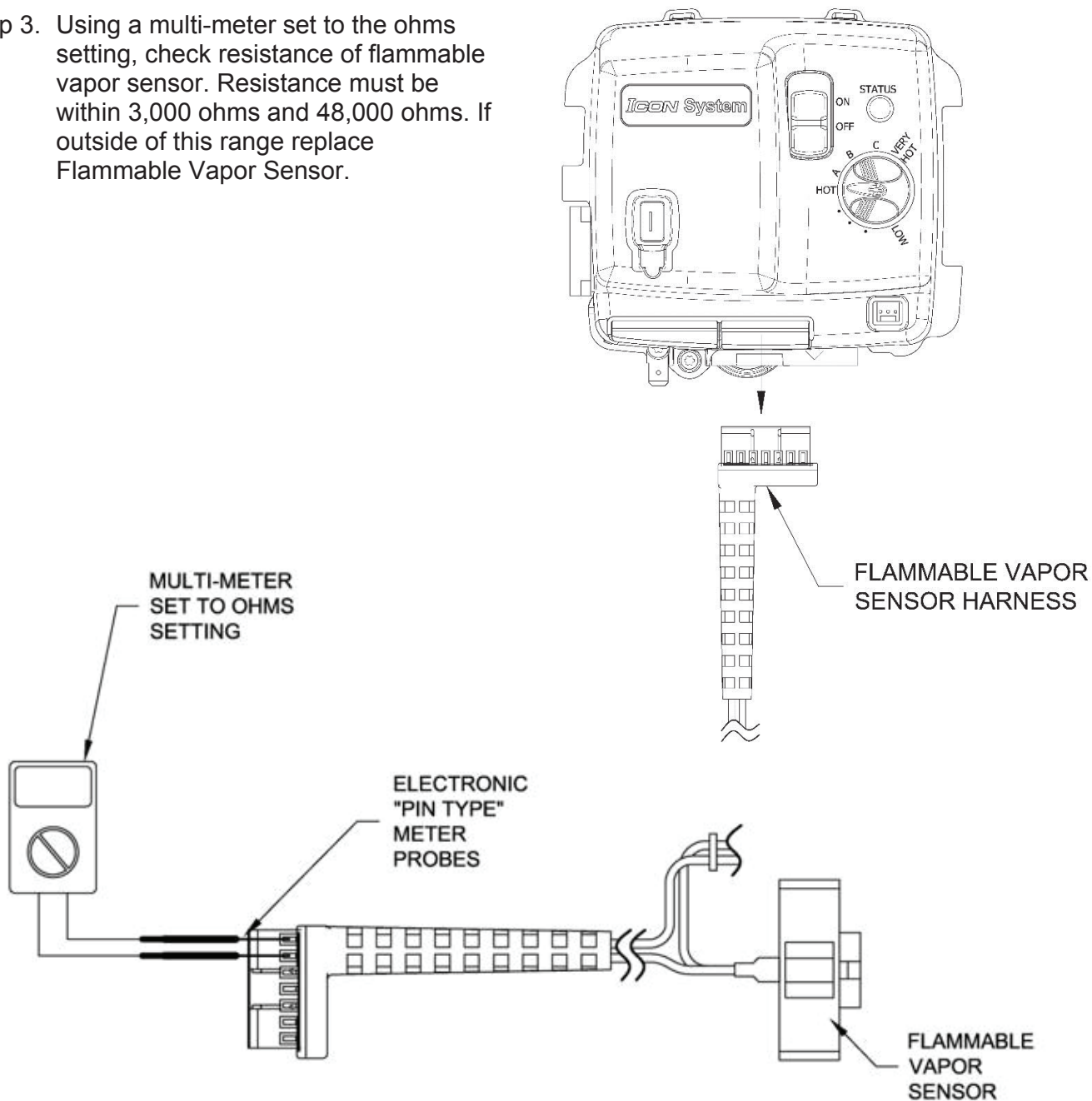

UPV Service Procedure IX – Safety Circuit Voltage Trace

Safety Circuit Voltage Trace

NOTE: This procedure assumes a cool tank.

⚠ WARNING

**115 volt potential exposure.
Use caution to avoid personal injury.**

Remove three screws (T20 Torx screwdriver) from control access cover on blower and remove cover (see photo 20).

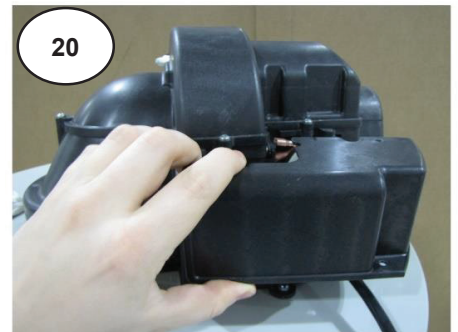
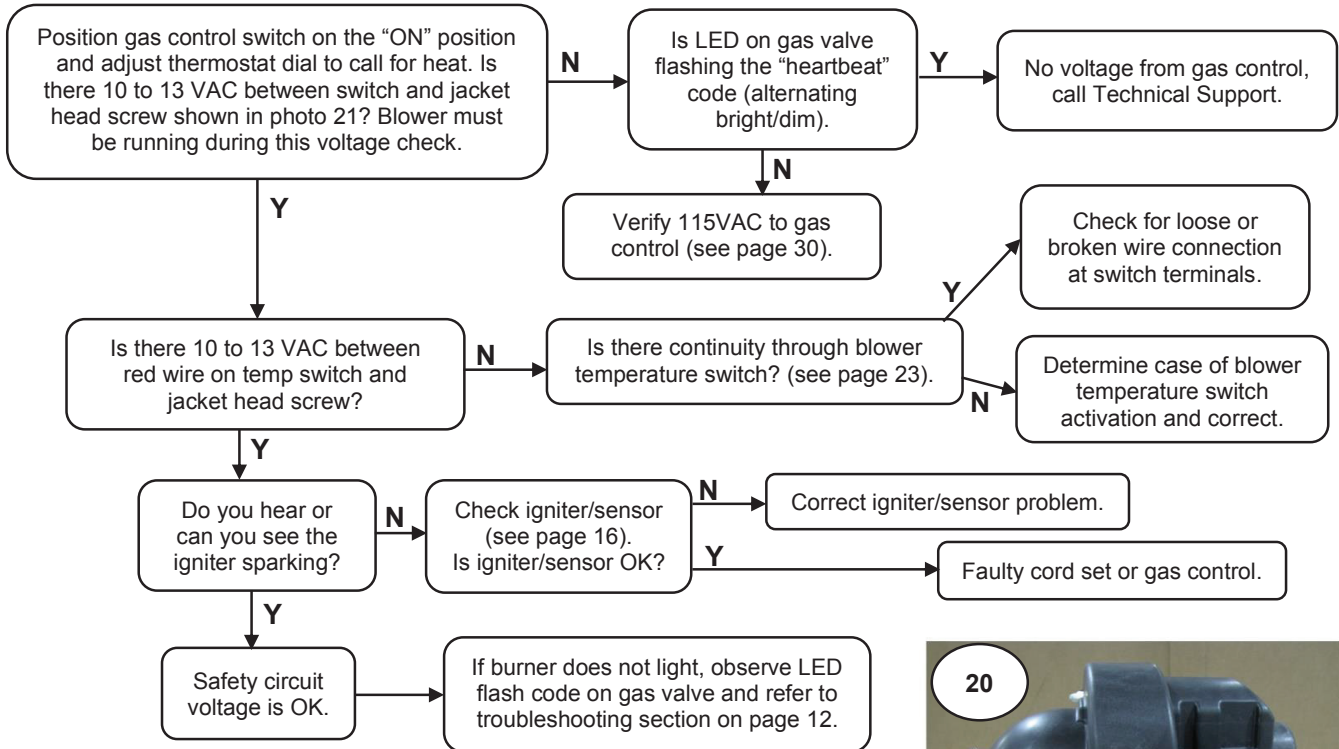

Blue wire leading to blower temp. switch

Red wire leading from pressure switch

Jacket head screw

UPV Service Procedure X – 115 VAC Circuit Trace

115 VAC Circuit Trace

Step 1. Verify 115 VAC and proper polarity at wall outlet.

Step 2. With the unit plugged in and control power switch in the "ON" position, verify LED status.

⚠ WARNING
115 volt potential exposure.
Use caution to avoid personal injury.

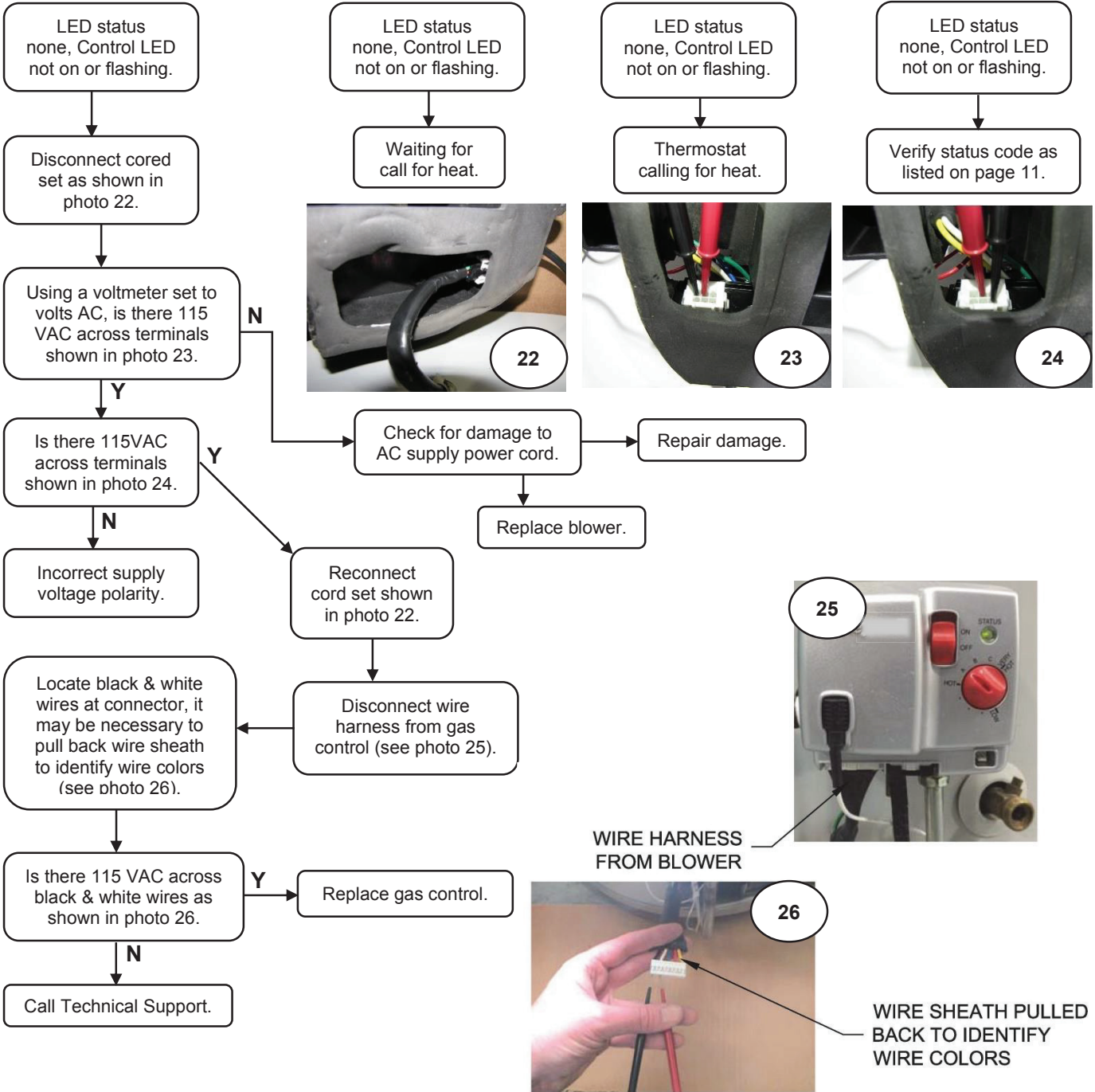

Check for 115VAC between black & white wires.
 -NOTE-
 Electronic meter probes required. Use care not to damage connector during this check.

Diptube Inspection and Replacement

WARNING

Water heater components and stored water may be HOT when performing the following steps in this procedure. Take necessary precaution to prevent personal injury.

- Step 1. Position on/off switch of gas control valve to “OFF” position and unplug water heater from wall outlet.
- Step 2. Turn OFF cold water supply to water heater. Connect hose to drain valve of water heater and route to an open drain. Open a nearby hot water faucet to vent heater for draining. Open drain valve of water heater and allow heater to drain to a point below the inlet connection nipple.
- Step 3. Disconnect inlet nipple from plumbing system.
- Step 4. With an appropriate tool such as a pipe wrench, remove inlet nipple/diptube from the water heater. Use caution not to damage pipe threads.
- Step 5. Visually inspect inlet nipple/dip tube. Inlet nipple/diptube should be free of cracks and any blockage. Hydrojet slots should be open and free of any blockage. Any damage such as cracks, restriction due to deformation or unintentional holes are not field repairable and the inlet nipple/dip tube must be replaced.
- Step 6. Upon completion of inspection or subsequent replacement, reinstall inlet nipple/dip tube into water heater. Ensure pipe dope is used on the nipple’s threads. Connect nipple to plumbing system, resume water supply and refill with water.
- Step 7. To resume operation, follow the instructions located on the lighting instruction label or the lighting instructions located in the Installation and Operation Manual.

Anode Inspection and Replacement

⚠ WARNING

Water heater components and stored water may be HOT when performing the following steps in this procedure. Take necessary precaution to prevent personal injury.

- Step 1. Position on/off switch of gas control valve to the “OFF” position and unplug water heater from wall outlet.
- Step 2. Turn OFF cold water supply to water heater. Connect hose to drain valve of water heater and route to an open drain. Open a nearby hot water faucet to vent water heater for draining. Open drain valve of water heater and allow water heater to drain to a point below the outlet connection nipple.
- Step 3. Disconnect outlet nipple from plumbing system.
- Step 4. With an appropriate tool such as a pipe wrench, remove outlet nipple/anode from the water heater. Use caution not to damage pipe threads.
- Step 5. Visually inspect outlet nipple/anode. Outlet nipple/anode should show signs of depletion, this is normal. If depletion is $\frac{1}{2}$ of the original anode diameter (approximately $\frac{3}{4}$ ” diameter), replacement is recommended. If any of the steel core of the anode is exposed, replacement is recommended.
- Step 6. Upon completion of inspection or subsequent replacement, reinstall outlet nipple/anode into water heater. Ensure pipe dope is used on the nipple’s threads. Connect nipple to plumbing system, resume water supply and refill with water.
- Step 7. To resume operation, follow the instructions located on the lighting instruction label or the lighting instructions located in the Installation and Operation Manual.

Flue Baffle Inspection and Replacement

- Step 1. Position gas control power switch to the “OFF” position and unplug blower from wall outlet.
- Step 2. Disconnect vent system the top of blower. Remove the three blower mounting screws (1/4” nut driver) (see photo 27).
- Step 3. Unplug harness from blower.
- Step 4. Remove blower with gasket from water heater.
- Step 5. Remove flue baffle from heater (see photo 28).
- Step 6. Inspect baffle for deterioration and any missing restrictors. Clean any scale or debris build up. Replace with new baffle as necessary.
- Step 7. Reinstall baffle into flue tube. Be sure hanger tabs are inserted into notch location at the top of the flue tube (see photos 28 & 29).
- Step 8. Check burner to ensure no scale has accumulated during this operation. See Burner Cleaning Procedure.
- Step 9. Connect vent system and cord set to blower. Reinstall blower on water heater. Plug water heater into wall outlet.
- Step 10. To resume operation, follow the lighting instruction located on the lighting instruction label or the lighting instructions located in the Installation and Operation Manual.

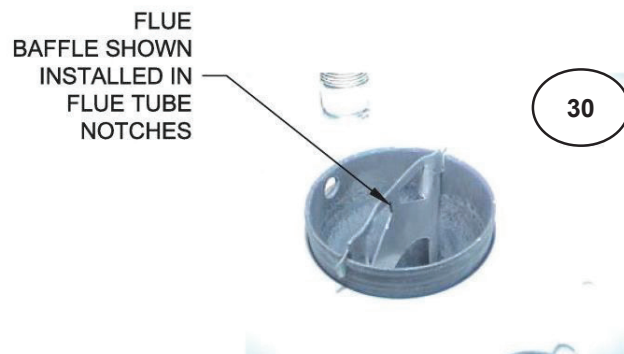
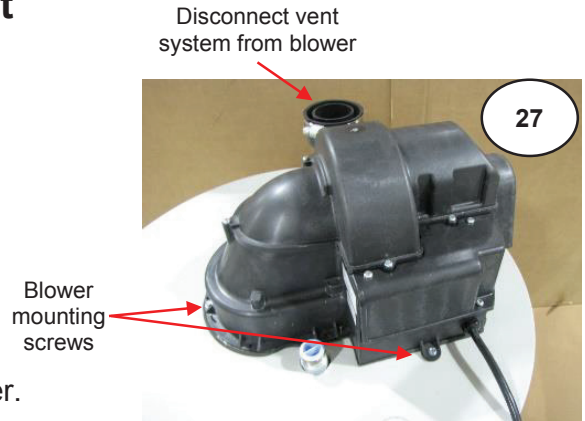

UPV Service Procedure XIV – Inner Door/Gasket Removal, Inspection, and Replacement

Inner Door Removal Procedure

Step 1. Position gas control power switch to the “OFF” position.

Step 2. Remove outer jacket burner access door.

Step 3. Disconnect main burner feedline (3/4” wrench), pilot tube (7/16” wrench) and white igniter/flame sense wire from the gas valve.

Step 4. Remove (4) 1/4” hex drive screws from right side inner door.

Step 5. Remove (3) 1/4” drive screws from left side burner door.

Step 6. Remove the connectors attached to the resettable thermal switch on the manifold mount.

Step 7. Remove the flammable vapor sensor from the clip by pushing down the tab to open the clip.

Step 8. Remove inner door and inspect per step 9.

Step 9. Fully inspect inner door gaskets for the following:

- Tears
- Missing material
- Cracks
- Dirt or debris
- Other imperfections that will inhibit proper seal
- Gasket adhesion to inner door
- Material on combustion chamber

If the gasket is not affected by any of the above, gasket replacement may not be required. If replacement is required, proceed to **Inner Door Gasket Replacement Procedure**.

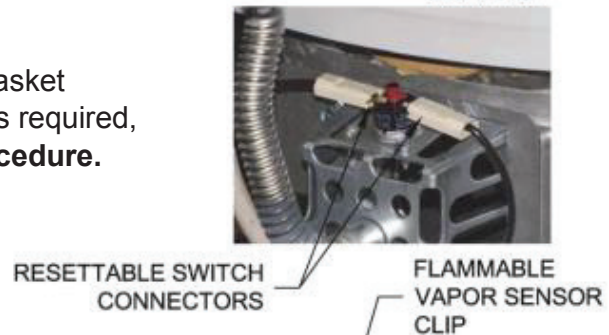
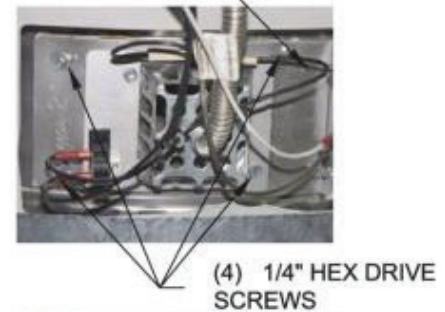
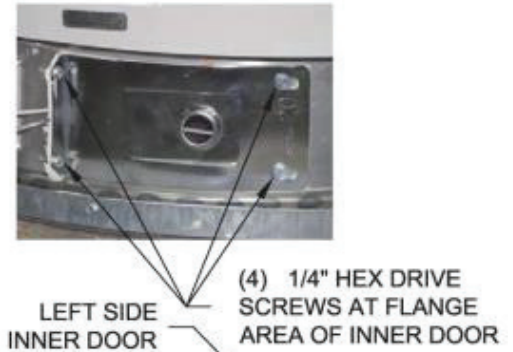
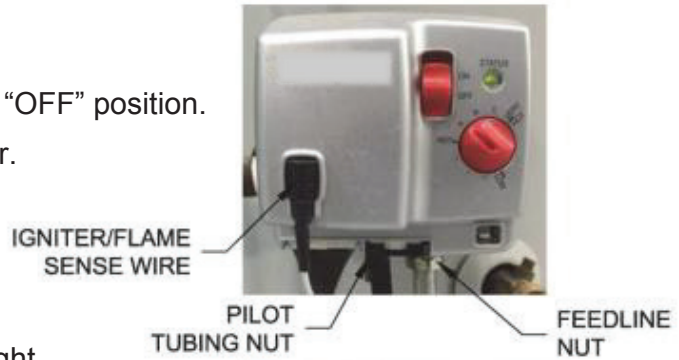

UPV Service Procedure XIV – Inner Door/Gasket Removal, Inspection, and Replacement

Inner Door Gasket Replacement Procedure

WARNING

If the information in these instructions is not followed exactly, a fire or explosion may result causing property damage, personal injury, or death.

- Step 1. After inspection of inner door as noted in Inner Door Removal Procedure Step 9, completely remove gasket and adhesive residue from right and left side inner doors as needed.
- Step 2. Use RTV sealant (recommended bead size 1/8") to secure the inner door gasket to the inner door sections (right & left). Refer to illustration on next page for proper application. Note the overlap configuration in the flange area of the inner door. Set the flange section first, this will help to achieve the proper overlap position.

Installation of Inner Door with Gasket

WARNING

Stripped fastener connections may allow for seal breach of inner door. A seal breach may result in a fire or explosion causing property damage, personal injury, or death. DO NOT over tighten screws in Steps 2, 4 and 5.

- Step 1. Clean any residual gasket residue or other debris from combustion chamber surface before installing the inner door/gasket assembly.
- Step 2. Place the left side inner door into position first. Using the 1/4" hex drive screws, secure left side inner door in place. **DO NOT OVER TIGHTEN SCREWS.**
- Step 3. Position the pilot tube and spark igniter wire against the left side inner door flange gasket.
- Step 4. Firmly place right side inner door flange against the left side inner door flange and secure with (2) 1/4" hex drive screws. **DO NOT OVER TIGHTEN SCREWS.**

UPV Service Procedure XIV – Inner Door/Gasket Removal, Inspection, and Replacement

Inner Door Gasket Replacement Procedure cont.

Step 5. Align right side inner door to combustion chamber and verify the fastener holes of the combustion chamber are aligned with right side inner door slotted opening. Verify seal integrity around combustion opening. Secure right side inner door using 1/4" hex drive screws. **DO NOT OVER TIGHTEN SCREWS.** Verify both left and right sides of inner door are properly positioned and sealed against the combustion chamber.

Step 6. Replace outer jacket burner access door.

Step 7. To resume operation, follow the instructions located on the lighting instruction label or the lighting instructions located in the Installation and Operation Manual.

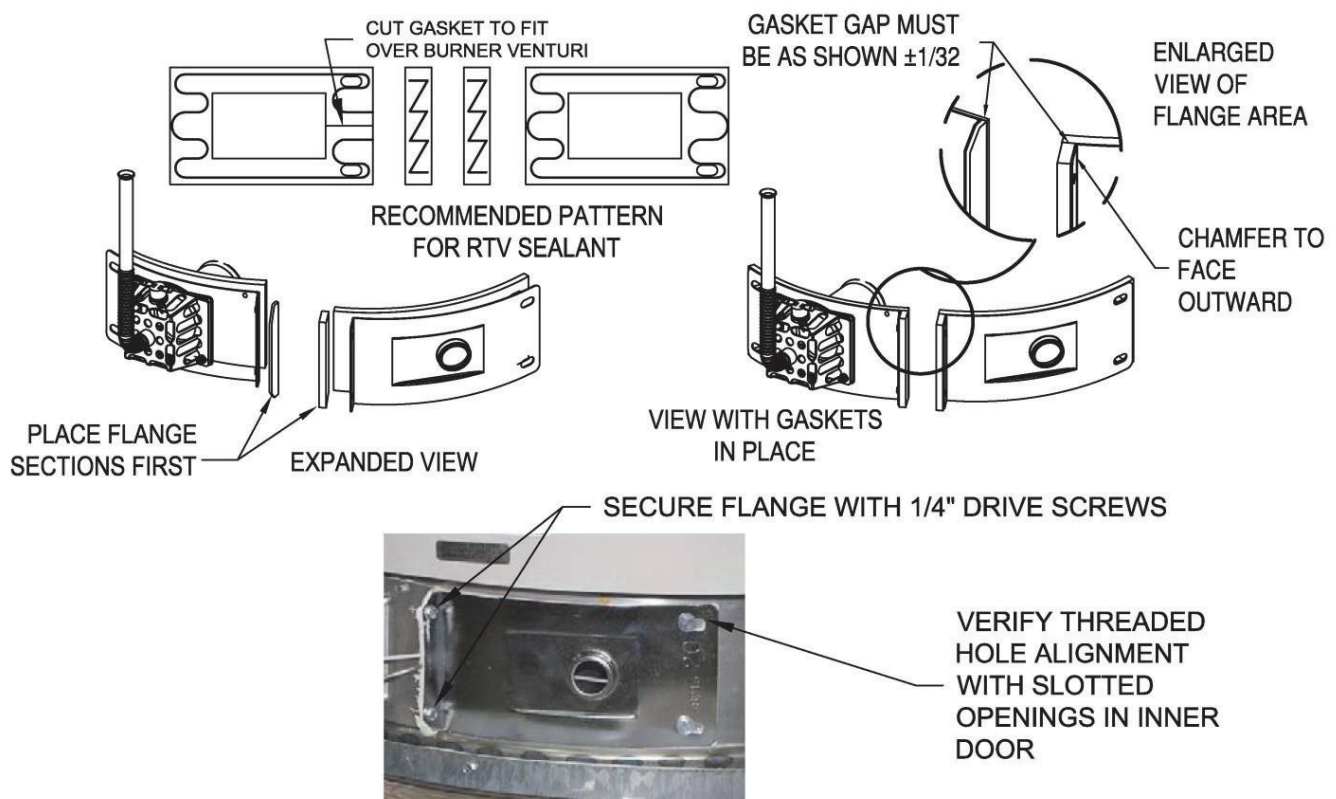

UPV Service Procedure XV – Resettable Thermal Switch Testing and Replacement

Resettable Thermal Switch Continuity Testing

- Step 1. Remove outer jacket door.
- Step 2. Disconnect black wire leads from the resettable thermal switch.
- Step 3. Using a multimeter capable of measuring continuity (Ohms), place one probe of the meter on one of the brass connection tabs of the resettable thermal switch, and the remaining probe on the other connection tab.
- Step 4. If continuity is indicated, the switch is closed, allowing millivolt current to pass.
- Step 5. If continuity is not indicated, the switch is open, possibly due to an overheating condition. The switch is designed to open at predetermined temperatures. An open switch can be reset by depressing the red colored button located at the center of the switch. The overheating condition must be determined prior to putting the water heater back into service.

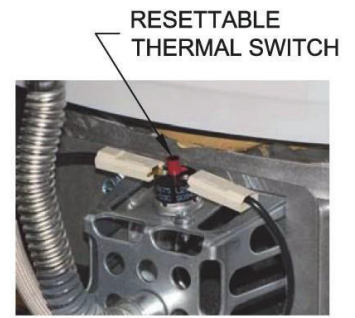

Probable Cause for Resettable Thermal Switch Activation	
Probable Cause	Corrective Action
Insufficient combustion air	<ol style="list-style-type: none"> 1. Verify adequate combustion air supply is available. 2. Clear jacket slot openings of any dirt, dust, restrictions or other obstructions. 3. Inspect flame arrestor plate and clean with a stiff brush, compressed air and/or vacuum to remove scale deposits and debris.
<ol style="list-style-type: none"> 1. Weak switch or switch is out of calibration. 2. Incorrect switch. 	<ol style="list-style-type: none"> 1. Replace resettable thermal switch. 2. Verify switch color code and approximate temperature.
Flammable vapor incident	Replace water heater

Resettable Thermal Switch Color Code Reference	
Color code	Approximate switch activation temperature (open)
Blue	240°
Yellow	270°
Red	290°

UPV Service Procedure XV – Resettable Thermal Switch Testing and Replacement

Resettable Thermal Switch Replacement

- Step 1. Rotate the gas control knob to the “OFF” position.
- Step 2. Remove the outer jacket door.
- Step 3. Disconnect the black wire leads from the resettable thermal switch.
- Step 4. Remove (2) ¼” hex drive screws from the manifold mount.
- Step 5. Remove the resettable thermal switch from manifold mount (Phillips screwdriver).
- Step 6. Place new resettable thermal switch in place. Be sure contact surface of resettable thermal switch and manifold mount are free of any debris. Secure resettable thermal switch into place using screws from Step 4. **DO NOT OVER TIGHTEN SCREWS.**
- Step 7. Reconnect the black wire leads from gas valve and thermopile to resettable thermal switch.
Note: Wire terminations are interchangeable with either resettable thermal switch connection.
- Step 8. Replace the outer jacket door.
- Step 9. To resume operation, follow the instructions located on the lighting instruction label or the lighting instruction located in the Installation and Operation Manual.

GAS CONTROL
SHOWN IN THE
"OFF" POSITION



MANIFOLD
MOUNT



ScreenLok® Flame Arrestor Cleaning

NOTICE

Some models are not equipped with the ScreenLok® Flame Arrestor.

- Step 1. Position the gas control power switch to the “OFF” position. Remove outer door.
- Step 2. Remove the outer jacket door and inner door per Service Procedure XIV. Disconnect main burner feedline ($\frac{3}{4}$ ” wrench), pilot tube ($\frac{7}{16}$ ” wrench) and igniter/flame sensor wire from gas control and remove burner assembly from combustion chamber.
- Step 3. Clean ScreenLok® Flame Arrestor using stiff brush, compressed air and/or shop vacuum to remove any scale or other debris accumulation. Using a soft brush, clear jacket openings from any dirt, dust, restrictions, or other obstructions.
- Step 4. Remove any debris from burner assembly per the Burner Cleaning Procedure and reinstall burner assembly into combustion chamber.
- Step 5. Reconnect feedline, pilot tube and igniter/flame sensor wire to the gas control. Reinstall outer jacket door and inner door per Service Procedure XIV. To resume operation, follow the instructions located on the lighting instruction label or the lighting instruction located in the Installation and Operation Manual.

Frozen Exhaust Vent Terminal

If an exhaust vent terminal is blocked with ice or snow due to severe conditions, the pressure switch and control will not allow the burner to operate. This will result in a three flash status code. Once the blockage is removed (through melting or other means) the controls will let the burner operate. The position of the vent terminals in relation to each other and terminals from other appliances can have an effect on the potential for blockage due to ice or snow.

See the installation instructions for recommended positioning of the terminals.

Glossary of Terms

BTU	British Thermal Units	PSI	Pounds per Square Inch
GPM	Gallons per Minute	RPM	Revolutions per Minute
Hz	Hertz	ECO	Energy Cut Out
kWhr	Kilowatt Hour	VAC	Volts Alternating Current
LED	Light Emitting Diode	“W.C.”	Inches of Water Column
NPT	National Pipe Thread	°C	Degrees Centigrade
Ohms	Ohms of resistance	°F	Degrees Fahrenheit

UPV Series - Parts List and Diagram

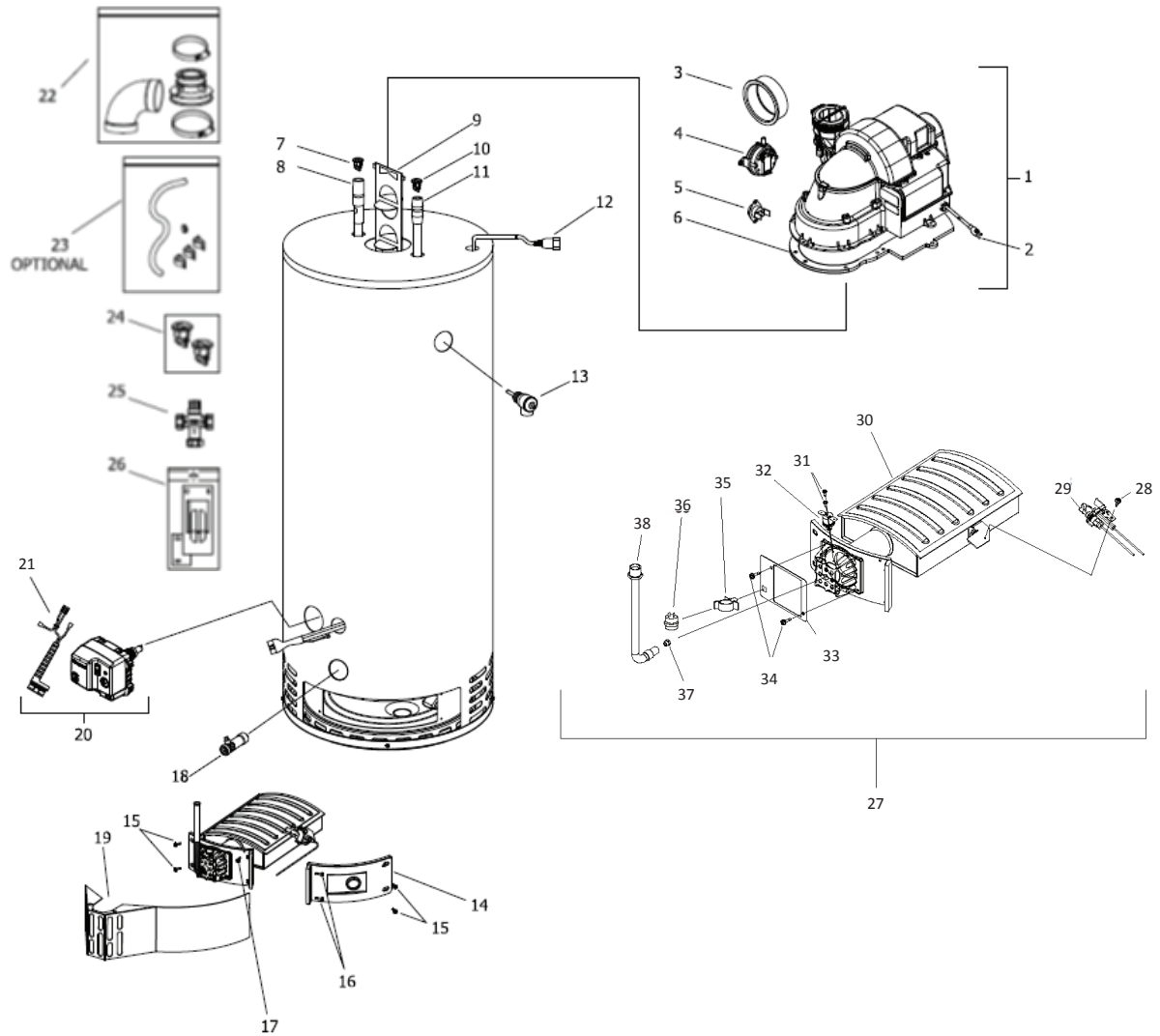

Part List

1. Blower Complete	11. Cold Water Diptube (inlet)	21. Vapor Sensor Harness	30. Burner
2. Power Cord	12. Blower Harness	22. 2" Exhaust Adapter	31. Screw #6-20 x 3/8
3. Gasket Adapter Rubber PVC	13. T&P Valve	23. Condensate Hose Kit	32. Thermal Switch
4. Pressure Switch	14. Right Side Inner Door	24. Kit – Heat Trap Insert	33. FVIR Sensor Plate
5. Blower Temp. Switch	15. Screw #10-12 x 3/4	25. Mixing Valve	34. Screw #8-18 x 1/4
6. Blower Gasket	16. Screw #8/18 x 3/4	26. Inner Door Gasket Kit	35. Vapor Sensor Clip
7. Heat Trap Outlet	17. Screw #8 x 3/4	27. Burner Assembly	36. Vapor Sensor
8. Hot Water Anode (Outlet)	18. Drain Valve	28. Screw #8-18 1/2	37. Burner Orifice
9. Flue Baffle	19. Outer Door	29. Pilot Assembly	38. Feedline
10. Heat Trap (inlet)	20. Gas Valve		



United States

Sales 800-523-2931

Technical Support 800-334-3393

Email techserv@bradfordwhite.com

Warranty 800-531-2111

Email warranty@bradfordwhite.com

Service Parts 800-538-2020

Email parts@bradfordwhite.com

Canada

Sales & Technical Support 866-690-0961 905-203-0600

Fax 905-636-0666

Warranty bwccwarranty@bradfordwhite.com

Technical Support bwccotech@bradfordwhite.com

Service Parts orders@bradfordwhitecanada.com

Orders ca.orders@bradfordwhite.com

For U.S. and Canada field service,
contact your professional installer or
local Bradford White sales representative.

International

General Contact international@bradfordwhite.com