



COMMERCIAL ELECTRIC REPLACEMENT PARTS LIST

CEHD Series ElectriFLEX HD™ (Heavy Duty) Models



Models Covered:
CEHD50(A)
CEHD80(A)
CEHD120(A)

Includes Hydrojet®
Total Performance System

Effective: October, 2024
ECO 8780



**NOTE: BOTH MODEL AND SERIAL
NUMBERS ARE REQUIRED FOR
ORDERING REPLACEMENT PARTS**

Dimensions and specifications
subject to change without notice.

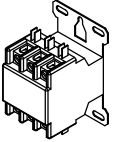
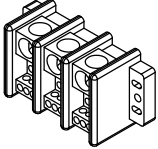
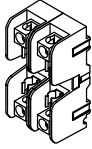
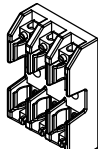
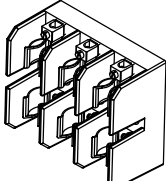
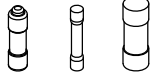

As required by the state of California Proposition 65.

CONTROL PANEL PARTS

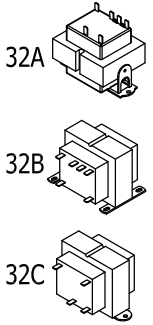
CONTACTORS	TERMINAL BLOCKS	FUSE BLOCKS			FUSES	GROUND LUG	TRANSFORMER
 <p>23</p>	 <p>24</p>	 <p>25</p>	 <p>26</p>	 <p>27</p>	 <p>28 29 30</p>	 <p>31</p>	 <p>32A 32B 32C</p>

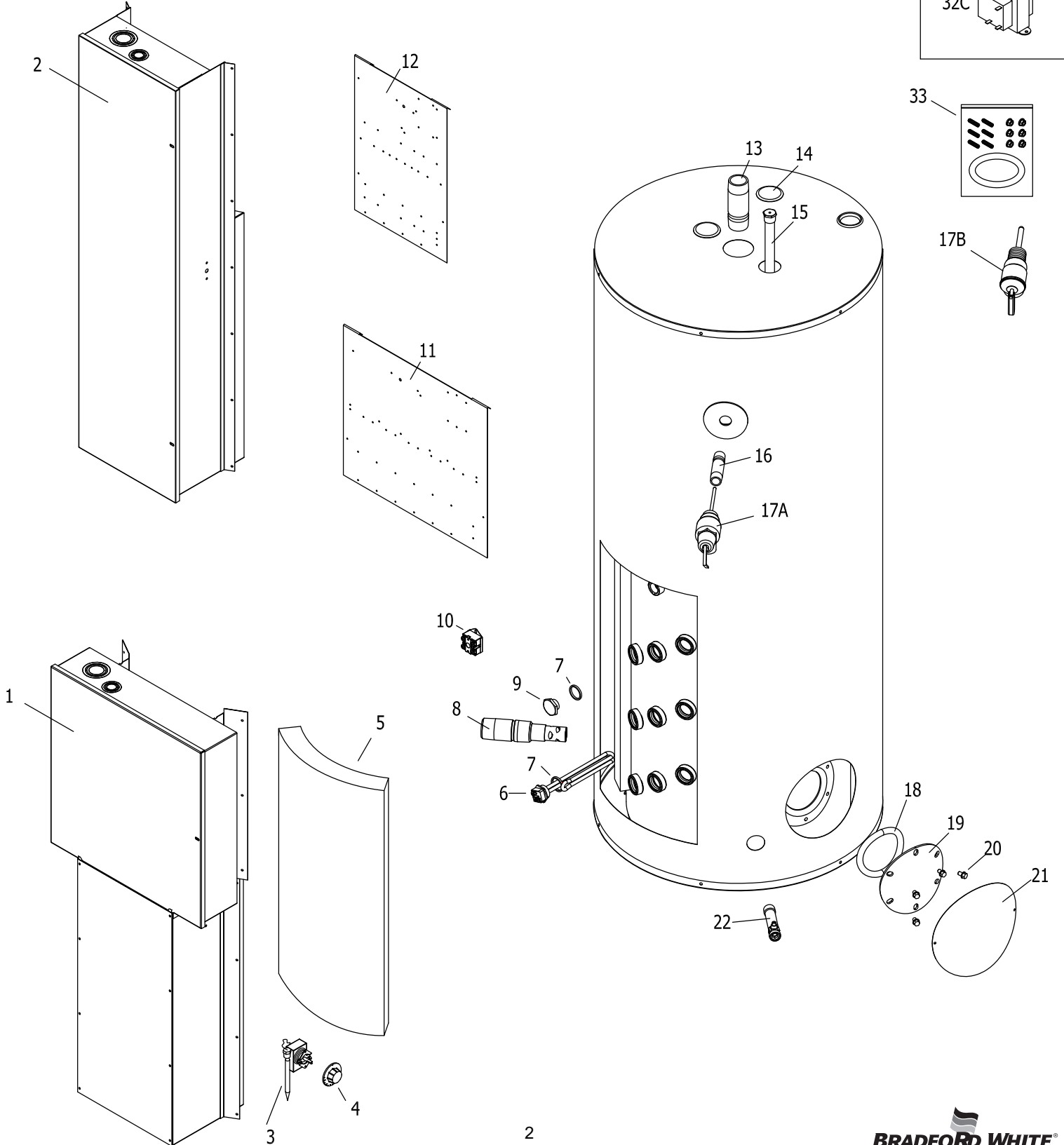

Item	Description	Model	Model	Model
		CEHD50(A)	CEHD80(A)	CEHD120(A)
1	Large Control Box	239-50581-00	239-50581-00	239-50581-00
2	Small Control Box	239-50576-00	239-50576-00	239-50576-00
3	Thermostat	264-33460-00	264-33460-00	264-33460-00
4	Thermostat Dial	264-33459-00	264-33459-00	264-33459-00
5	Element Insulation	226-50896-00	226-50896-00	226-50896-00
6	Heating Element ▲	See Element Table	See Element Table	See Element Table
7	Element Gasket	223-34019-00	223-34019-00	223-34019-00
8	Inlet Diptube	415-44731-00	415-44731-00	415-44731-00
9	Element Plug	223-34020-00	223-34020-00	223-34020-00
10	High Limit Switch	219-50925-00	219-50925-00	219-50925-00
11	Large Control Panel	239-50682-00	239-50682-00	239-50682-00
12	Small Control Panel	239-50575-00	239-50575-00	239-50575-00
13	Outlet Nipple	229-40913-01	229-40913-06	229-40913-06
14	Hole Cover	239-31547-02	239-31547-02	239-31547-02
15	Magnesium Anode #	415-55483-00	415-55483-00	415-55483-00
	Aluminum Anode #	415-55485-00	415-55485-00	415-55485-00
	A420 Aluminum Anode #	415-55487-00	415-55487-00	229-49559-04
16	3/4 NPT Nipple	229-32762-09	229-32762-09	229-32762-09
17A	Temperature & Pressure Relief Valve Male Thread ♦	415-32920-04	415-32920-04	415-32920-04
17B	Temperature & Pressure Relief Valve Female Thread ♦	415-30246-00	415-30246-00	415-30246-00
18	Cleanout O-Ring	205-18427-00	205-18427-00	205-18427-00
	Cleanout Gasket (ASME)	205-32942-00	205-32942-00	205-32942-00
19	Cleanout Cover	205-18428-00	205-18428-00	205-18428-00
	Cleanout Cover (ASME)	205-32941-00	205-32941-00	205-32941-00
20	Cleanout Screw 5/16-18x3/4 (6 Req'd)	239-32970-00	239-32970-00	239-32970-00
21	Jacket Cleanout Cover	243-20299-00	243-20299-00	243-20299-00
22	Drain Valve	415-42351-04	415-42351-04	415-42351-04
23	Contactora	264-41988-01	264-41988-01	264-41988-01
24	Terminal Block	264-32245-00	264-32245-00	264-32245-00
25	Fuse Block 2 Pole (3A)(208V/240V/277V/380V/415V/480V/600V)	264-53307-00	264-53307-00	264-53307-00
26	Fuse Block 3 Pole (40A)(208V/240V/277V/380V/415V/480V)	264-32264-00	264-32264-00	264-32264-00
27	Fuse Block 3 Pole (40A)(600V)	264-41975-00	264-41975-00	264-41975-00
28	Fuse Slow Blow "CC" Class (3A)(208V/240V/277V/380V/415V/480V/600V)	264-53306-00	264-53306-00	264-53306-00
29	Fuse Fast Blow "G" Class (40A)(208V/240V/277V/380V/415V/480V)	264-32267-00	264-32267-00	264-32267-00
30	Fuse Fast Blow "T" Class (40A)(600V)	264-41976-02	264-41976-02	264-41976-02
31	Ground Lug	264-32250-00	264-32250-00	264-32250-00
32A	Transformer (208V/240V/480V)*	415-41994-01	415-41994-01	415-41994-01
	Transformer (277V/380V/415V)*	415-41994-02	415-41994-02	415-41994-02
32B	Transformer (208V/240V/480V)*	415-41995-01	415-41995-01	415-41995-01
	Transformer (277V/380V/415V)*	415-41995-02	415-41995-02	415-41995-02
32C	Transformer (600V)*	415-41996-00	415-41996-00	415-41996-00
33	Kit-Cleanout (Not For Use With ASME Tanks)	415-54256-00	415-54256-00	415-54256-00

Anode may need to be cut to length, please see page 4 reference chart of anode length by model.

♦ 17A for 3 element models only, 17B for 6 and 9 element models.

* 32A for 3 element models only, 32B for 6 and 9 element models. 32C for all 600V models.

Heating Elements (Incoloy)

Wattage	208 Volt	240 Volt	277 Volt	380 Volt	415 Volt	480 Volt	600 Volt
2000W	415-42545-14	415-42545-02	415-42547-07	415-51868-15	415-42551-12	415-42553-01	415-44340-01
3000W	415-42545-12	415-42545-15	415-42545-15	415-42551-10	415-42551-13	415-42553-08	415-44340-02
4000W	415-42545-17	415-42545-12	415-42547-03	415-42551-16	415-42551-14	415-42553-03	415-44340-03
4100W	415-42543-07	415-42545-21	415-42547-17	---	---	415-42553-16	---
4500W	415-42545-19	415-51328-07	415-42547-12	415-42551-17	415-42551-15	415-42553-11	415-44340-04
5000W	415-42543-04	415-42545-18	415-42547-15	415-42551-18	415-42551-16	415-42553-12	415-44340-05
6000W	415-42543-06	415-42545-19	415-42547-14	415-42549-05	415-42551-18	415-42553-14	415-44340-06

▲ Element gaskets included with elements.



United States

Sales 1-800-523-2931
Technical Support 1-800-334-3393
Email techsupport@bradfordwhite.com
Warranty 1-800-531-2111
Email warranty@bradfordwhite.com
Service Parts 1-800-538-2020
Email parts@bradfordwhite.com

Canada

Sales 1-866-690-0961 1-905-203-0600
Fax 905-636-0666
Warranty 1-800-531-2111
Email warranty@bradfordwhite.com
Technical Support 1-800-334-3393
Email techsupport@bradfordwhite.com
Service Parts and Orders ca.orders@bradfordwhite.com

For U.S. and Canada field service, contact your professional installer or local Bradford White sales representative.

International

General Contact international@bradfordwhite.com