



RESIDENTIAL GAS REPLACEMENT PARTS LIST

Super High Efficiency Atmospheric Vent “RG2F” Models

Models Covered:
RG2F40S
RG2F50S



Effective: October, 2024
ECO 8780

**NOTE: BOTH MODEL AND SERIAL
NUMBERS ARE REQUIRED FOR
ORDERING REPLACEMENT PARTS**

Dimensions and specifications
subject to change without notice.



As required by the state of California Proposition 65.

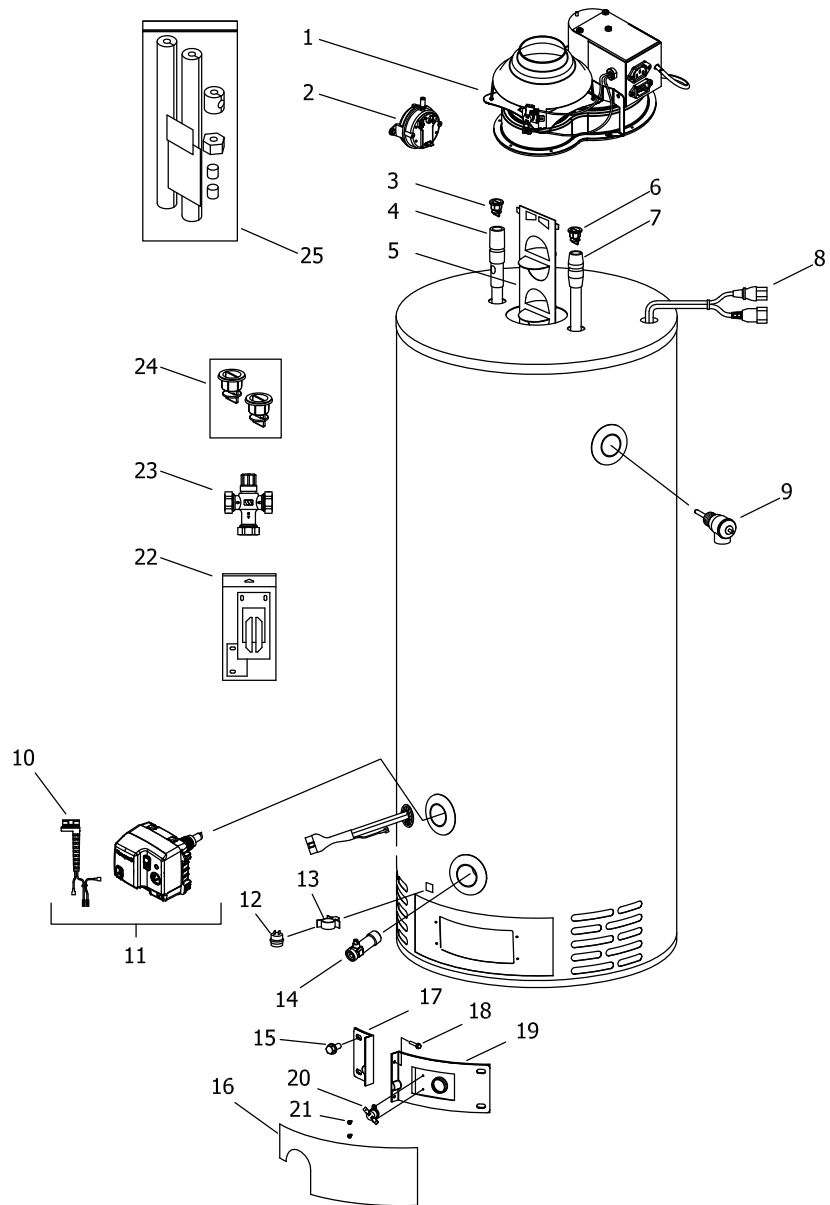

Item	Description	Model	Model
		RG2F40S	RG2F50S
1	Blower Complete	239-48697-00	239-48697-00
	Blower Complete High Altitude (2,001 Ft. to 7,000 Ft.)	243-50204-00	243-50204-00
2	Pressure Switch	239-48754-01	239-48754-01
	Pressure Switch High Altitude (2,001 Ft. to 7,000 Ft.)	239-48754-02	239-48754-02
3	Heat Trap Insert (Outlet)	415-45167-00	415-45167-00
4	Hot Water Outlet Anode (Magnesium)▲#	415-55482-00	415-55482-00
	Hot Water Outlet (Aluminum)▲#	415-55484-00	415-55484-00
	Hot Water Outlet A420 (Aluminum)▲#	415-55486-00	415-55486-00
5	Restrictor Baffle	243-49081-00	243-49082-00
6	Heat Trap Insert (Inlet)	415-51556-00	415-51556-00
7	Cold Water Inlet ▲▲	229-53466-02	415-51230-17
8	Wire Harness	239-45617-03	239-45617-03
9	T&P Relief Valve	415-40594-02	415-40594-02
10	Gas Valve Wire Harness	239-50066-00	239-50066-00
11	Gas Valve Assembly Kit	239-48795-02	239-48795-02
12	Flammable Vapor Sensor	415-45560-00	415-45560-00
13	Flammable Vapor Sensor Clip	239-45648-00	239-45648-00
14	Brass Drain Valve	415-42351-02	415-42351-02
15	Screw-#10-12 x 3/4 HWH	239-52581-00	239-52581-00
16	Outer Door	243-43962-00	243-43962-00
17	Left Side Inner Door Complete	239-43968-18	239-43968-20
18	Screw-#8-18 x 3/4 HWH	239-44195-00	239-44195-00
19	Right Side Inner Door Complete	239-43963-06	239-43963-09
20	Resettable Thermal Switch	415-43676-01	415-43676-01
21	Screw-#6-20 x 3/8 PHCR	239-43967-00	239-43967-00
22	Inner Door Gasket Kit	239-44078-00	239-44078-00
23	ASSE Approved Mixing Valve (optional)	239-51778-00	239-51778-00
24	Kit-Heat Trap Insert (Inlet & Outlet)	265-51572-00	265-51572-00
25	Insulation Kit	239-48949-00	239-48949-00

* Applies to all warranties

** Inner door gasket kit recommended

Anode may need to be cut to length, see page 6.

▲ Order with item 3

▲▲ Order with item 6

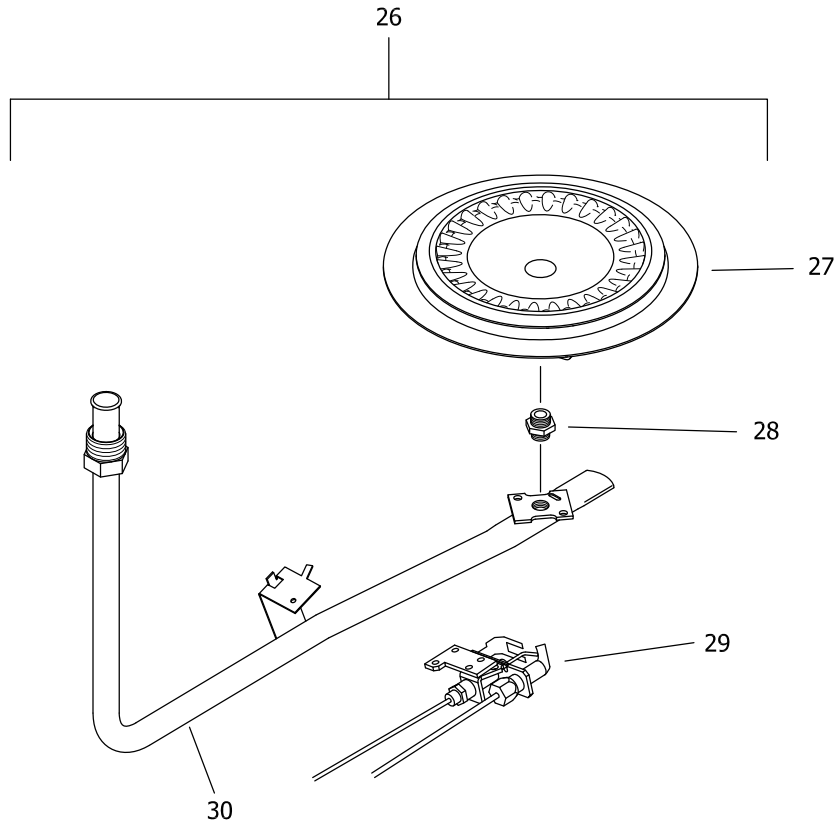

NATURAL GAS (BN) BURNER ASSEMBLY

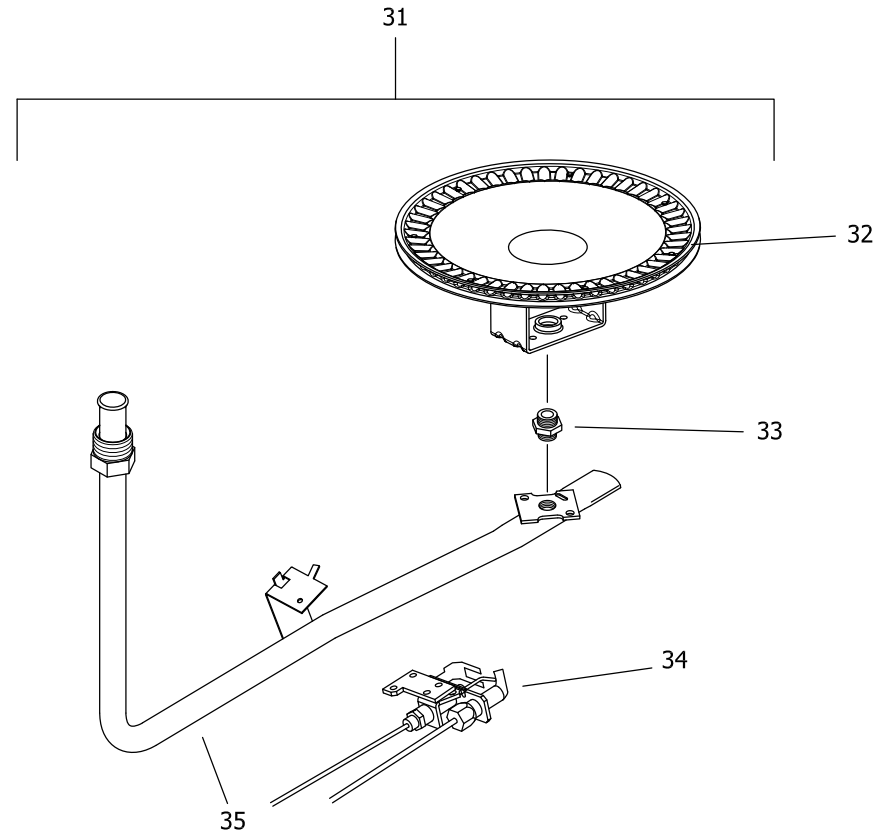

LP GAS (SX) BURNER ASSEMBLY

Item	Description	Model RG2F40S	Model RG2F50S
Natural Gas (N) Burner Assembly			
26	Nat Gas Burner Assembly Complete***	265-45652-02-33	265-45652-04-33
27	Nat. Gas (N) Burner**	228-42506-00	228-42506-00
28	Nat. Gas (N) Main Burner Orifice 0 Ft. to 2,000 Ft.**	234-41034-33	234-41034-33
	Nat. Gas (N) High Altitude 2,001 Ft. to 7,000 Ft. (-475 model suffixes) **	234-41034-36	234-41034-36
	Nat. Gas (N) High Altitude Kit 7,001 Ft. to 10,000 Ft.	265-51380-08-41	265-51380-08-41
29	Nat. Gas Pilot Assembly**	415-45653-05	415-45653-05
30	Nat. Gas Feedline**	233-45615-02	233-45615-04
LP Gas (X) Titanium Stabilized Stainless Steel Burner Assembly			
31	LP Gas Burner Assembly Complete***	265-47316-02-50	265-47316-03-50
32	LP Gas (X) Burner**	228-46964-00	228-46964-00
33	LP Gas (X) Main Burner Orifice 0 Ft. to 2,000 Ft. **	234-47064-50	234-47064-50
	LP Gas (X) High Altitude 2,001 Ft. to 7,000 Ft. (-475 model suffixes) **	234-47064-52	234-47064-52
	LP Gas (X) High Altitude Kit 7,001 Ft. to 10,000 Ft.	265-51433-08-53	265-51433-08-53
34	LP Gas Pilot Assembly**	415-45653-05	415-45653-05
35	LP Gas Feedline**	233-47109-02	243-47316-06
	LP to Natural Gas Conversion Kit (Norm Alt.)	265-46493-89	265-46493-90
	LP to Natural Gas Conversion Kit (High Alt.)	265-46493-80	265-46493-92

** Inner door gasket kit recommended

*** Ordering a complete burner assembly may increase delivery time. Please order the specific component required for the quickest delivery.



United States

Sales 1-800-523-2931
Technical Support 1-800-334-3393
Email techsupport@bradfordwhite.com
Warranty 1-800-531-2111
Email warranty@bradfordwhite.com
Service Parts 1-800-538-2020
Email parts@bradfordwhite.com

Canada

Sales 1-866-690-0961 1-905-203-0600
Fax 905-636-0666
Warranty 1-800-531-2111
Email warranty@bradfordwhite.com
Technical Support 1-800-334-3393
Email techsupport@bradfordwhite.com
Service Parts and Orders ca.orders@bradfordwhite.com

For U.S. and Canada field service, contact your professional installer or local Bradford White sales representative.

International

General Contact international@bradfordwhite.com