













## Installation and Instruction Manual

# ***Pipe Cover***

Model LT199NXX1 / LT199PXX1  
LT199NRX1 / LT199PRX1  
RTGS199N1 / RTGS199X1  
RTGR199N1 / RTGR199X1

## Included Pipe Cover Kit

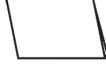
Part		Shape	Q'ty	Part		Shape	Q'ty
1	Front Cover		1	6	Frame Bracket 1		2
2	Left Plate		1	7	Frame Bracket 2		1
3	Right Plate		1	8	Dry Wall Anchor		2
4	Front Cover Bracket		1	9	Screws (M4x10L)		12
5	Case Bracket		2	10	Knob		1
				11	Installation Instruction		1

## Pipe Cover Kit Components & Dimension

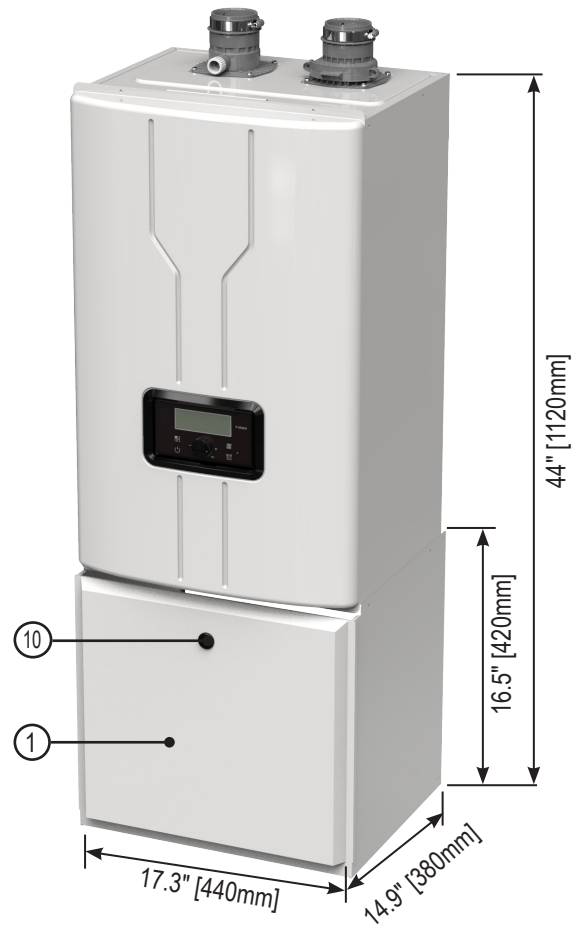
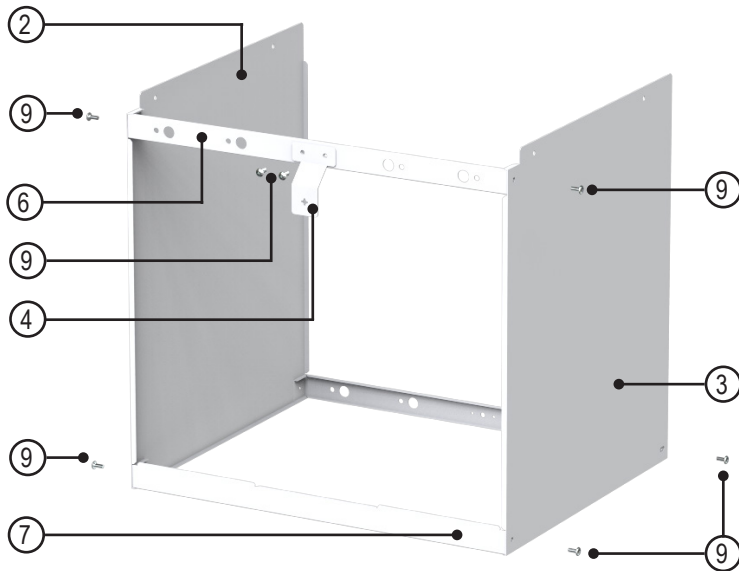

## Installing the Pipe Cover

### 1. Pre-Assemble Frame before installation

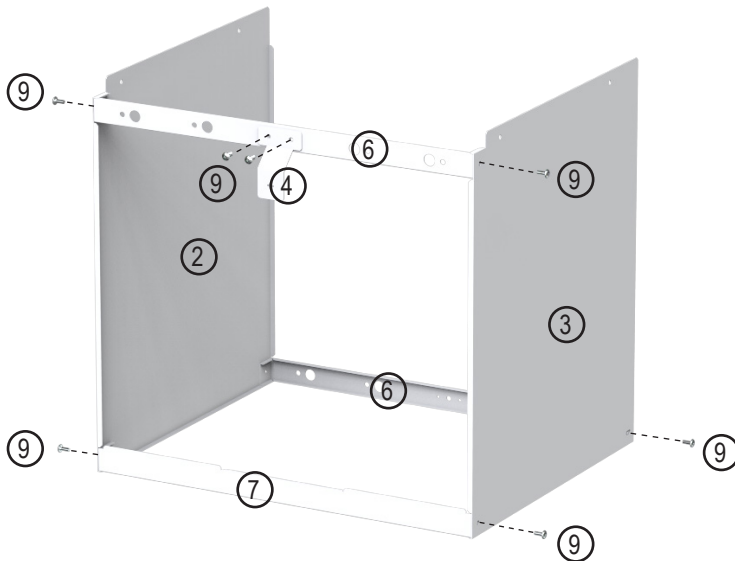

- 1) Assemble the Front Cover Bracket (4) to the one of the Frame Bracket 1 (6).
- 2) Assemble this Frame Bracket 1 (6) assembled Front Cover Bracket (4) to the Left and Right Plate (2,3) with Screws-M4x10L (9).
- 3) Secure the two Frame Brackets 1, 2 (6,7) to the Left and Right Plate (2,3) with Screws-M4x10L (9).

### 2. Install Pipe Cover onto Water Heater

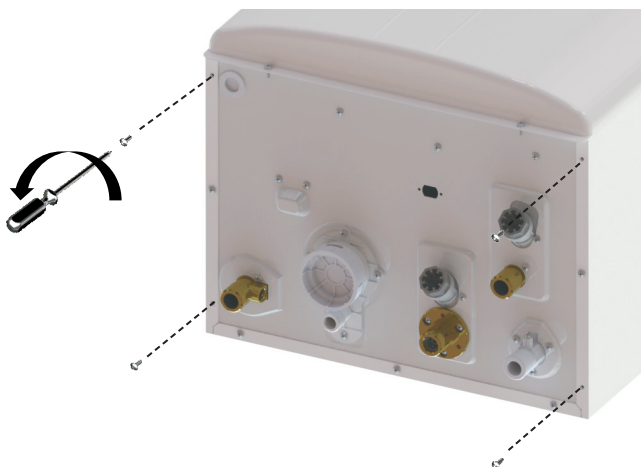

Figure 1

- 1) Remove the mounting 4 screws (A) from the bottom and sides of the appliance. Refer to Figure 1.
- 2) Install the two Case Brackets (5) to the bottom of the appliance with the 4 screws (A) removed in the previous step. Refer to Figure 2.

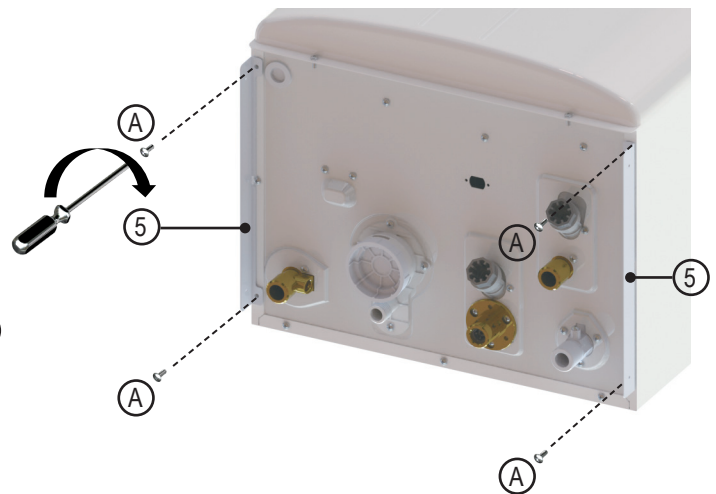

Figure 2

- 3) Slide the Pipe Cover assembly onto the bottom of the appliance. Align the mounting holes and temporarily mount the Pipe Cover with the 4 Screws-M4x10L (9). Refer to Figure 3.
- 4) The 'back' bottom Frame Bracket 1(6) inserts into the temporarily mounted Pipe Cover. Mark the locations to attach the Pipe Cover to the wall onto the 'back' bottom Frame Bracket 1(6).
- 5) Remove the Pipe Cover from the wall and then drill two holes on the wall as marked. For drywall, drill two 3/16-in. holes (other wall materials will require alternate mounting methods).

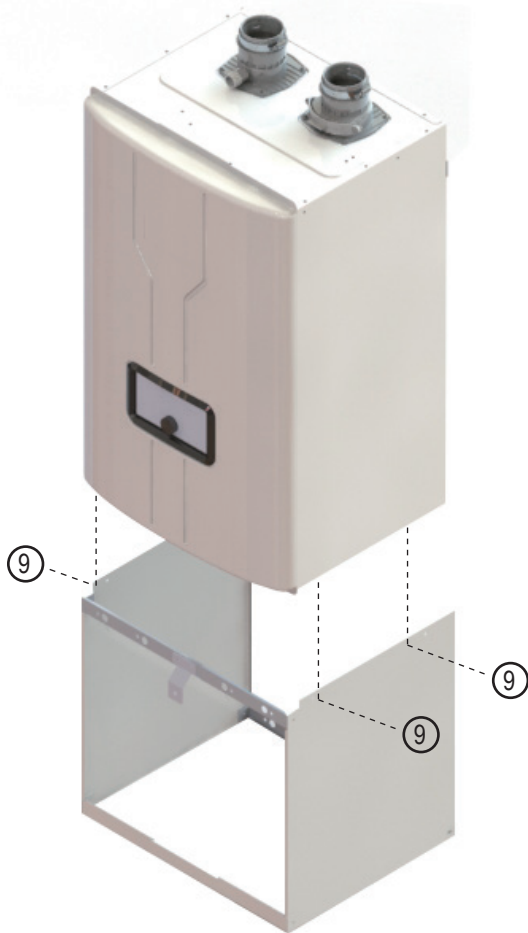

Figure 3

- 6) Attach 'back' bottom Frame Bracket 1(⑥) to the wall with two dry wall anchors (⑧). Refer to Figure 4.
- 7) Attach the pre-assembled Pipe Cover onto the bottom of the appliance. Tighten the 4 Screws-M4x10L (⑨) on the both sides of pre-assembled Pip Cover.
- 8) Attach the Front Cover (①) to the Pipe Cover with the Knob (⑩). Refer to Figure 5.
- 9) With the Pipe Cover flush with the appliance, tighten the screws on the bottom Frame Bracket 1(⑥) see Figure 5.



Figure 4

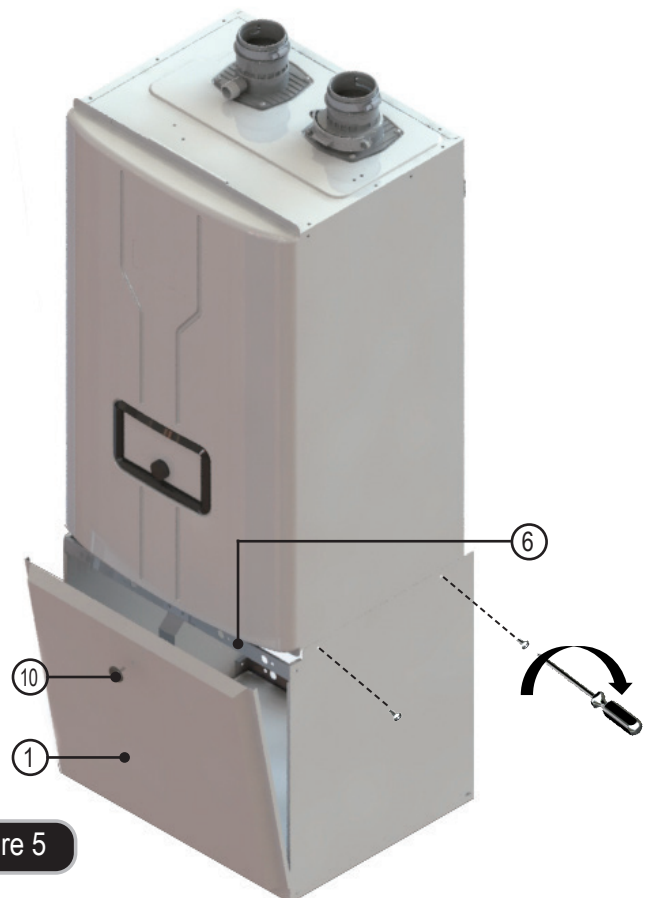

Figure 5