

Common Vent Kits Polypropylene

For use with **RTGS199** and **RTGR199** tankless water heaters

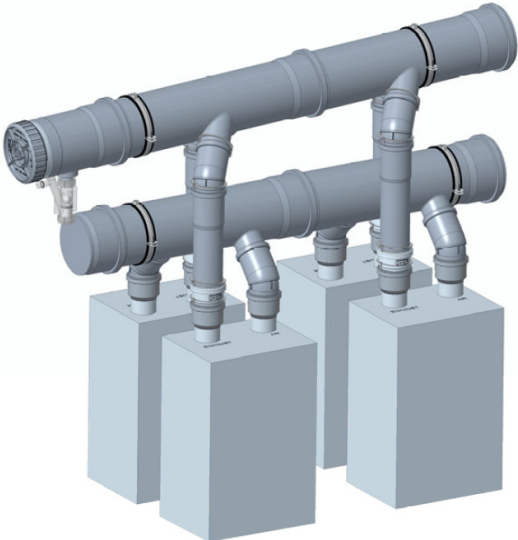

Date:

Project #:

Engineer:

Prepared By:

Bid Date:

Submittal Data

Project Name:

Location:

Contractor:

Features

- Allows up to 8 heaters to be installed with a polypropylene common vent system.
- Tested and listed to UL1738 and ULC-S636.
- Back-to-back and inline kits available.
- Spacing matches cascade rack system accessories.

Sizing

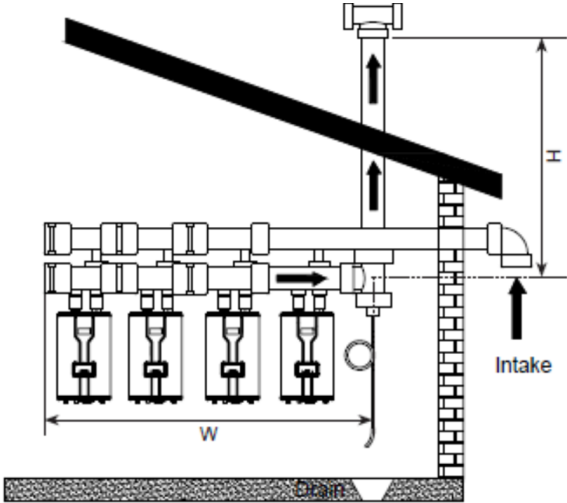

Required Load (Total BTU/H)	Number of Heaters	Total Common Vent Length (ft) = W+H		
		4" Diameter Vent	6" Diameter Vent	8" Diameter Vent
399,800	2	106	200	
599,700	3	71	160	
799,600	4	53	120	
999,500	5		96	150
1,199,400	6		80	142
1,393,300	7		68	121
1,599,200	8		60	106

Available Kits

4" Diameter Kits

Part Number	Description
D2023700	Exhaust vent starter kit, 4" back-to-back
D2023800	Exhaust vent extension kit, 4" back-to-back
D2023900	Intake air starter kit, 4" back-to-back
D2024000	Intake air extension kit, 4" back-to-back
D2024100	Exhaust vent starter kit, 4" side-by-side
D2024200	Exhaust vent extension kit, 4" side-by-side
D2024300	Intake air starter kit, 4" side-by-side
D2024400	Intake air extension kit, 4" side-by-side

6" Diameter Kits

Part Number	Description
D2024500	Exhaust vent starter kit, 6" back-to-back
D2024600	Exhaust vent extension kit, 6" back-to-back
D2024700	Intake air starter kit, 6" back-to-back
D2024800	Intake air extension kit, 6" back-to-back
D2024900	Exhaust vent starter kit, 6" side-by-side
D2025000	Exhaust vent extension kit, 6" side-by-side
D2025100	Intake air starter kit, 6" side-by-side
D2025200	Intake air extension kit, 6" side-by-side

8" Diameter Kits

Part Number	Description
D2025300	Exhaust vent starter kit, 8" back-to-back
D2025400	Exhaust vent extension kit, 8" back-to-back
D2025500	Intake air starter kit, 8" back-to-back
D2025600	Intake air extension kit, 8" back-to-back
D2025700	Exhaust vent starter kit, 8" side-by-side
D2025800	Exhaust vent extension kit, 8" side-by-side
D2025900	Intake air starter kit, 8" side-by-side
D2026000	Intake air extension kit, 8" side-by-side

Kit Contents

Exhaust vent starter kit, back-to-back

- D2023700 – 4" diameter
- D2024500 – 6" diameter
- D2025300 – 8" diameter

One kit serves two heaters, back-to-back

Kits contain:

- (2) Increasesers
- (2) Non-return valves
- (2) Connector vent lengths (heater to common vent)
- (2) 45° elbows
- Custom exhaust branch tee
- (8) Connector rings
- Horizontal drain fitting
- Ball valve siphon
- Support clamp
- Lubricant 50ml

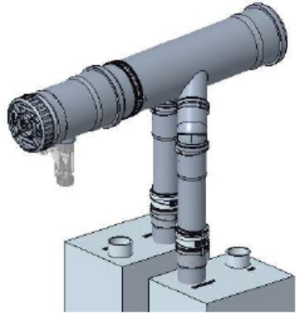

Exhaust vent extension kit, back-to-back

- D2023800 – 4" diameter
- D2024600 – 6" diameter
- D2025400 – 8" diameter

One kit adds two heaters to a starter kit, back-to-back

Kits contain:

- (2) Increasesers
- (2) Non-return valves
- (2) Connector vent lengths (heater to common vent)
- (2) 45° elbows
- Custom exhaust branch tee
- (8) Connector rings
- Support clamp

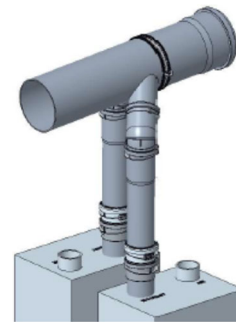

Intake air starter kit, back-to-back

- D2023900 – 4" diameter
- D2024700 – 6" diameter
- D2025500 – 8" diameter

One kit serves two heaters, back-to-back

Kits contain:

- (2) Increasesers
- (2) 45° elbows
- Custom intake air branch tee
- Tee cap
- Support clamp
- Lubricant 50ml

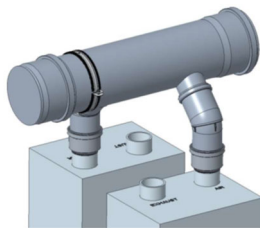

Intake air extension kit, back-to-back

- D2024000 – 4" diameter
- D2024800 – 6" diameter
- D2025600 – 8" diameter

One kit adds two heaters to a starter kit, back-to-back

Kits contain:

- (2) Increasesers
- (2) 45° elbows
- Custom intake air branch tee
- Support clamp

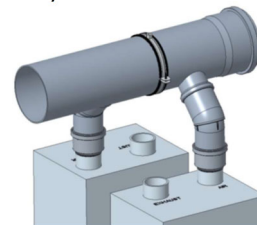

Common Vent Kits

Kit Contents (continued)

Exhaust vent starter kit, side-by-side

- D2024100 – 4" diameter
- D2024900 – 6" diameter
- D2025700 – 8" diameter

One kit serves two heaters, side-by-side

Kits contain:

- (2) Increases
- (2) Non-return valves
- (2) Connector vent lengths (heater to common pipe)
- (2) 87° elbows
- Custom exhaust inline branch tee
- (8) Connector rings
- Horizontal drain fitting
- Ball valve siphon
- Support clamp
- Lubricant 50ml

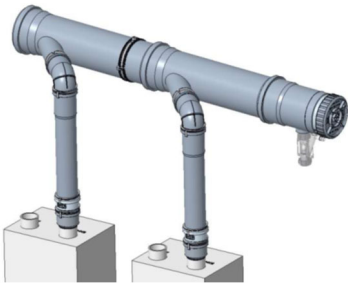

Exhaust vent extension kit, side-by-side

- D2024200 – 4" diameter
- D2025000 – 6" diameter
- D2025800 – 8" diameter

One kit adds one heater to a starter kit, side-by-side

Kits contain:

- Increaser
- Non-return valve
- Connector vent length (heater to common pipe)
- 87° elbow
- Custom exhaust inline branch tee
- (4) Connector rings
- Support clamp



Intake air starter kit, side-by-side

- D2024300 – 4" diameter
- D2025100 – 6" diameter
- D2025900 – 8" diameter

One kit serves two heaters, side-by-side

Kits contain:

- (2) Increases
- (2) 45° elbows
- Custom intake air inline branch tee
- Tee cap
- Support clamp
- Lubricant 50ml

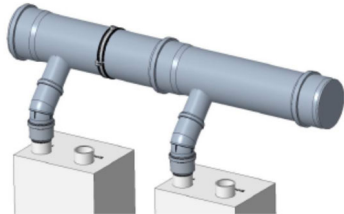

Intake air extension kit, side-by-side

- D2024400 – 4" diameter
- D2025200 – 6" diameter
- D2026000 – 8" diameter

One kit adds one heater to a starter kit, side-by-side

Kits contain:

- Increaser
- 45° elbow
- Custom intake air inline branch tee
- Support clamp

