

Contents

SECTION 1 General Information..... 1  
 1.A Introduction ..... 1  
 1.B Kit Includes ..... 2  
 SECTION 2 Vent Installation ..... 2  
 2.A Vent Materials ..... 2  
 2.B Required Components ..... 3  
 2.C Sizing a Common Vent System ..... 4  
 2.D Example System Sizing ..... 5  
 2.E Installation ..... 6  
 SECTION 3 Maintenance ..... 6  
 SECTION 4 Final Installation Checklist... 7  
 SECTION 5 Maintenance Checklist ..... 7

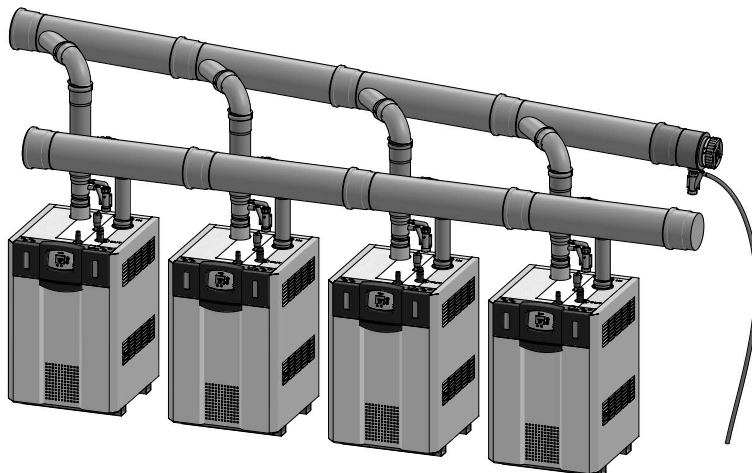

**⚠ WARNING: Carbon Monoxide Hazard**

A Non-Return Valve must be installed onto each unit.

Both the exhaust and air intake must be directly vented to the outside of the building. **Using room air for a common vent system is not permitted.**

All units in the common vent system must be the same model / size.

All installations must be made in accordance with the requirements of the relevant local utility or other authorities having jurisdiction, or in the absence of local or state code, the U.S. National Fuel Gas Code ANSI Z223.1/NFPA 54-latest edition, and in Canada, in accordance with the Natural Gas and Propane Installation Code CSA B149.1 – latest edition.

Carbon monoxide detectors, installed on the floor level where the gas appliance is to be located, are required by law in some jurisdictions, and are strongly recommended in all installations.

Improper installation of a venting system may lead to personal injury or death.

Independently tested and accepted by CSA to ANSI Z21.13 / CSA 4.9

**SECTION 1 General Information**

**1.A Introduction**

Bradford White offers a common venting solution for some models of the Brute product line of boilers and volume water heaters. This instruction manual provides information necessary for the safe setup and maintenance of such a system. Read it carefully before beginning a common venting installation.

The following Brute models are approved for common venting: BNTH080, BNTH105, BNTH150, BNTH210, BNTH285, BNTV285, BNTH399, BNTV399, BNTH500, BNTV500. Up to 8 Brute boilers or volume water heaters of a given model can be common vented.

H2399501B



200 Lafayette St.  
 Middleville, MI 49333  
 Warranty: (800) 531-2111

[www.BradfordWhite.com](http://www.BradfordWhite.com)  
 Litho in U.S.A. © Bradford White 26-03 Document 1427B-BW

**1.B Kit Includes**

The Non-Return Valve Kit includes the following components:

Kit Number	Description
CA016400	Non-Return Valve Kit, Neotherm 80 - 105
CA016401	Non-Return Valve Kit, Neotherm 150 - 210
CA016402	Non-Return Valve Kit, Neotherm 285 - 500

**Table 1: Non-Return Valve Kit Part Numbers**

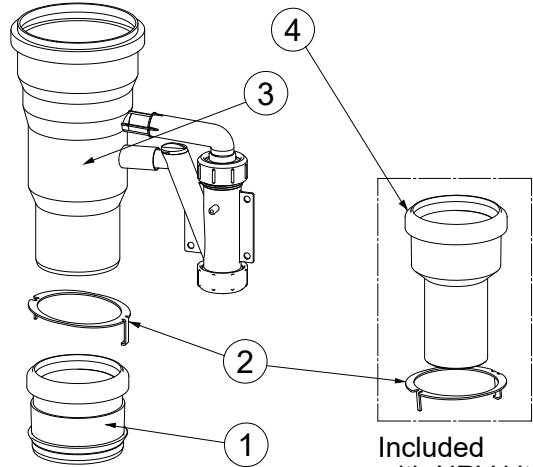

Included with NRV kit CA016400 Only

Item Number	Part Number			Venting Component
	CA016400	CA016401	CA016402	
1	D2020800	-	-	Appliance Adapter for Coupler Style Flue Collar, 2"
	-	D2020801	-	Appliance Adapter for Coupler Style Flue Collar, 3"
	-	-	D2020802	Appliance Adapter for Coupler Style Flue Collar, 4"
2	D2020900	-	-	Connector Ring, 2"
	D2020901	D2020901	-	Connector Ring, 3"
	-	-	D2020902	Connector Ring, 4"
3	D2021000	D2021000	-	Non-Return Valve (NRV), 3" Inlet, 4" Outlet
	-	-	D2021001	Non-Return Valve (NRV), 4" Inlet, 4" Outlet
4	D2021100	-	-	Centric Increaser, 2" to 3"

**Table 2: Non-Return Valve Kit Components**

**SECTION 2 Vent Installation**

**2.A Vent Materials**

Centrotherm InnoFlue polypropylene venting can be used on both the exhaust and air intake, and must be used on the exhaust. PVC, CPVC, or ABS material may be used on the air intake only. All joints on both the exhaust and air intake must be properly sealed.



**WARNING:**

Only Centrotherm InnoFlue is allowed by CSA for use on the exhaust venting of Bradford White common vent systems. Do not mix components from different manufacturers in either the exhaust or intake venting.

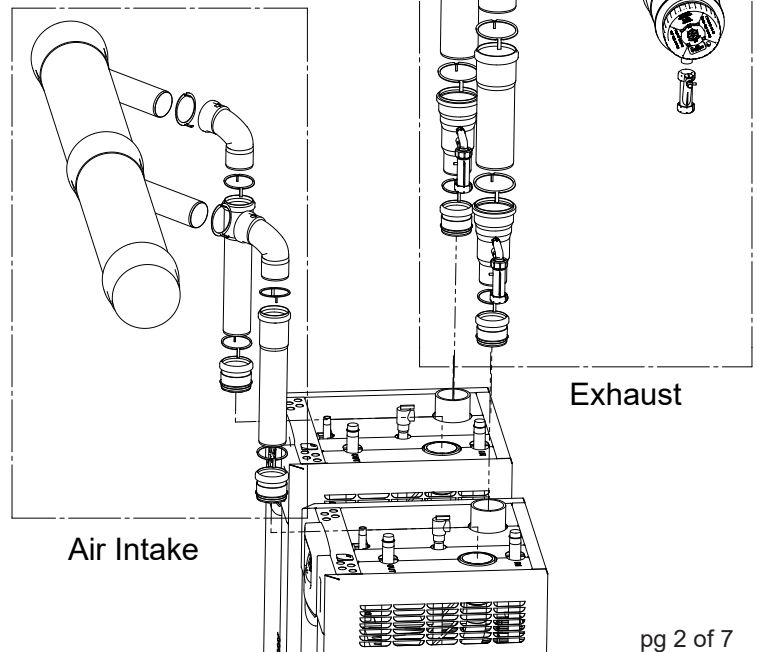

**2.B Required Components**

At minimum, the following components are required to install a common vent system.

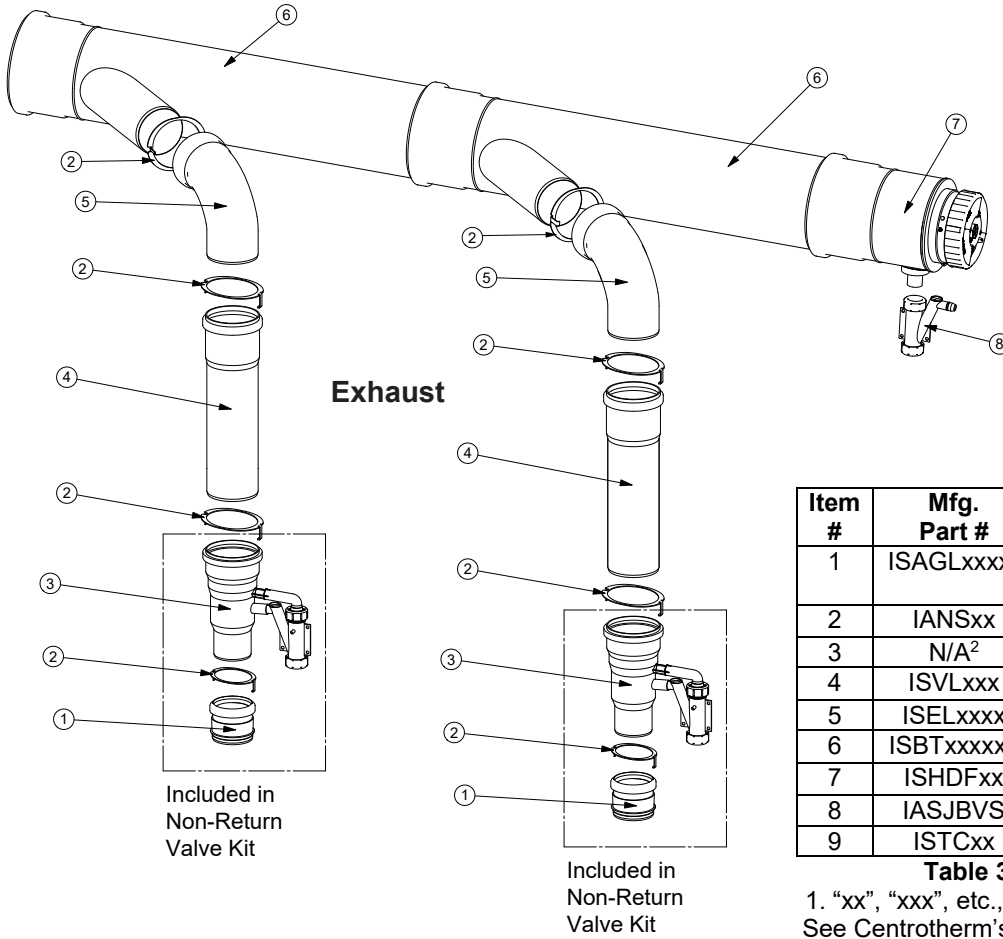

Item #	Mfg. Part #	Venting Component
1	ISAGLxxxx <sup>1</sup>	Appliance Adapter for Coupler Style Flue Collar
2	IANSxx	Connector Ring
3	N/A <sup>2</sup>	Non-Return Valve (NRV)
4	ISVLxxx	Vent Length
5	ISELxxxx	87° Elbow
6	ISBTxxxxxx	Branch Tee
7	ISHDFxx	Horizontal Drain Fitting
8	IASJBVS	Universal Ball Valve Siphon
9	ISTCxx	Tee Cap

**Table 3: Venting Components**

1. "xx", "xxx", etc., refers to variations in nominal size. See Centrotherm's catalog for a particular application.

2. Non-Return Valve must be purchased from Bradford White.

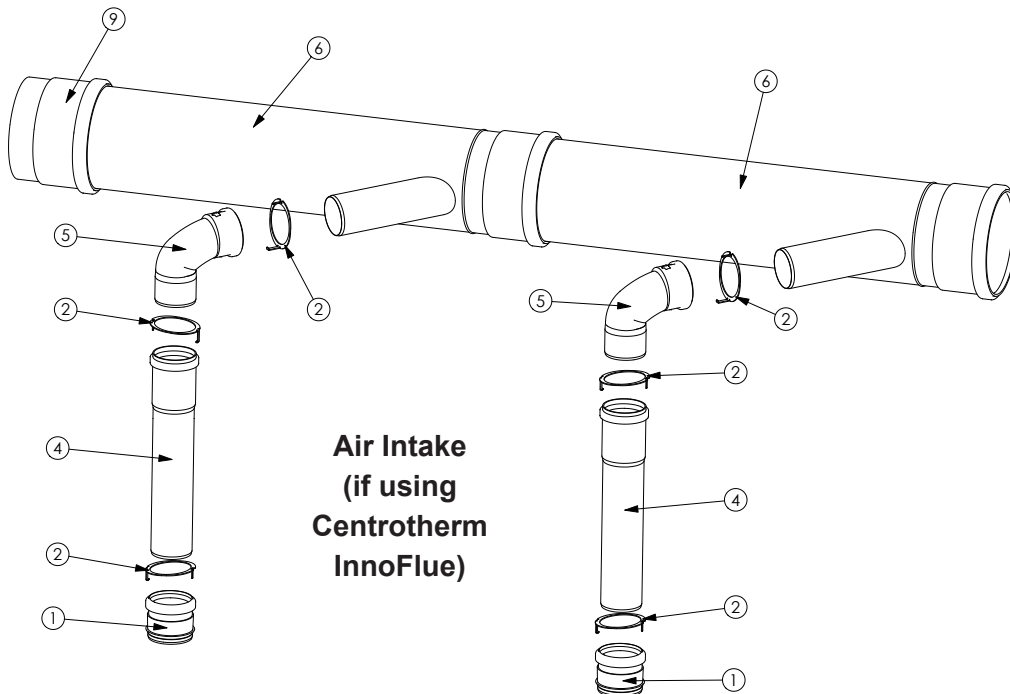

## 2.C Sizing a Common Vent System

Vents can be installed in a vertical or horizontal orientation. The maximum allowable equivalent lengths for the common vent system (air intake and exhaust each) are listed by boiler model, in tables 4-11 below. Keep in mind that this is the **equivalent** vent length, and that elbows create additional pressure drop which must be accounted for. Use an equivalent length of 8 feet for 87° or 90° elbows and 3 feet for 45° elbows.

Note that the branch tees directly above the boilers, as well as the individual boiler vent lengths feeding into the branch tees do not need to be included when sizing a common vent system. However, efforts must be made to minimize the lengths of these portions of the vent system. They should not exceed 5 feet of vent length above each boiler, and 3 feet of vent length between each boiler unless absolutely necessary.

1. To size a common vent system, first determine the total equivalent length of venting needed to reach the desired termination point.
2. Next, find the relevant maximum length table for the model that is being installed, and using the previously determined equivalent vent length, as well as the number of units in the installation, select a suitable trunk diameter for the vent.

Number of Units	Total Input (Btu/h)	Max. Equivalent Vent Length (ft)	
		5" Trunk	6" Trunk
2	160,000	100	100
3	240,000	100	100
4	320,000	100	100
5	400,000	100	100
6	480,000	89	100
7	560,000	66	100
8	640,000	51	100

Table 4: Max Equiv Vent Length for BNTH080

Number of Units	Total Input (Btu/h)	Max. Equivalent Vent Length (ft)		
		5" Trunk	6" Trunk	8" Trunk
2	300,000	100	100	100
3	450,000	96	100	100
4	600,000	55	100	100
5	750,000	36	100	100
6	900,000	25	95	100
7	1,050,000	N/A	70	100
8	1,200,000	N/A	54	100

Table 6: Max Equiv Vent Length for BNTH150

Number of Units	Total Input (Btu/h)	Max. Equivalent Vent Length (ft)	
		5" Trunk	6" Trunk
2	210,000	100	100
3	315,000	100	100
4	420,000	100	100
5	525,000	74	100
6	630,000	52	100
7	735,000	39	100
8	840,000	30	100

Table 5: Max Equiv Vent Length for BNTH105

Number of Units	Total Input (Btu/h)	Max. Equivalent Vent Length (ft)	
		6" Trunk	8" Trunk
2	420,000	100	100
3	630,000	100	100
4	840,000	100	100
5	1,050,000	65	100
6	1,260,000	46	100
7	1,470,000	34	97
8	1,680,000	26	75

Table 8: Max Equiv Vent Length for BNTH210

Number of Units	Total Input (Btu/h)	Max. Equivalent Vent Length (ft)		
		8" Trunk	10" Trunk	12" Trunk
2	798,000	100	100	100
3	1,197,000	95	100	100
4	1,596,000	54	100	100
5	1,995,000	35	100	100
6	2,394,000	25	87	100
7	2,793,000	N/A	64	100
8	3,192,000	N/A	49	100

Table 10: Max Equiv Vent Length for BNTH399 & BNTV399

Number of Units	Total Input (Btu/h)	Max. Equivalent Vent Length (ft)		
		6" Trunk	8" Trunk	10" Trunk
2	570,000	100	100	100
3	855,000	86	100	100
4	1,140,000	49	100	100
5	1,425,000	32	92	100
6	1,710,000	23	64	100
7	1,995,000	N/A	48	100
8	2,280,000	N/A	37	100

Table 9: Max Equiv Vent Length for BNTH285 & BNTV285

Number of Units	Total Input (Btu/h)	Max. Equivalent Vent Length (ft)		
		8" Trunk	10" Trunk	12" Trunk
2	1,000,000	73	100	100
3	1,500,000	36	100	100
4	2,000,000	20	72	100
5	2,500,000	N/A	47	100
6	3,000,000	N/A	33	100
7	3,500,000	N/A	24	79
8	4,000,000	N/A	N/A	61

Table 11: Max Equiv Vent Length for BNTH500 BNTV500

**2.D Example System Sizing**

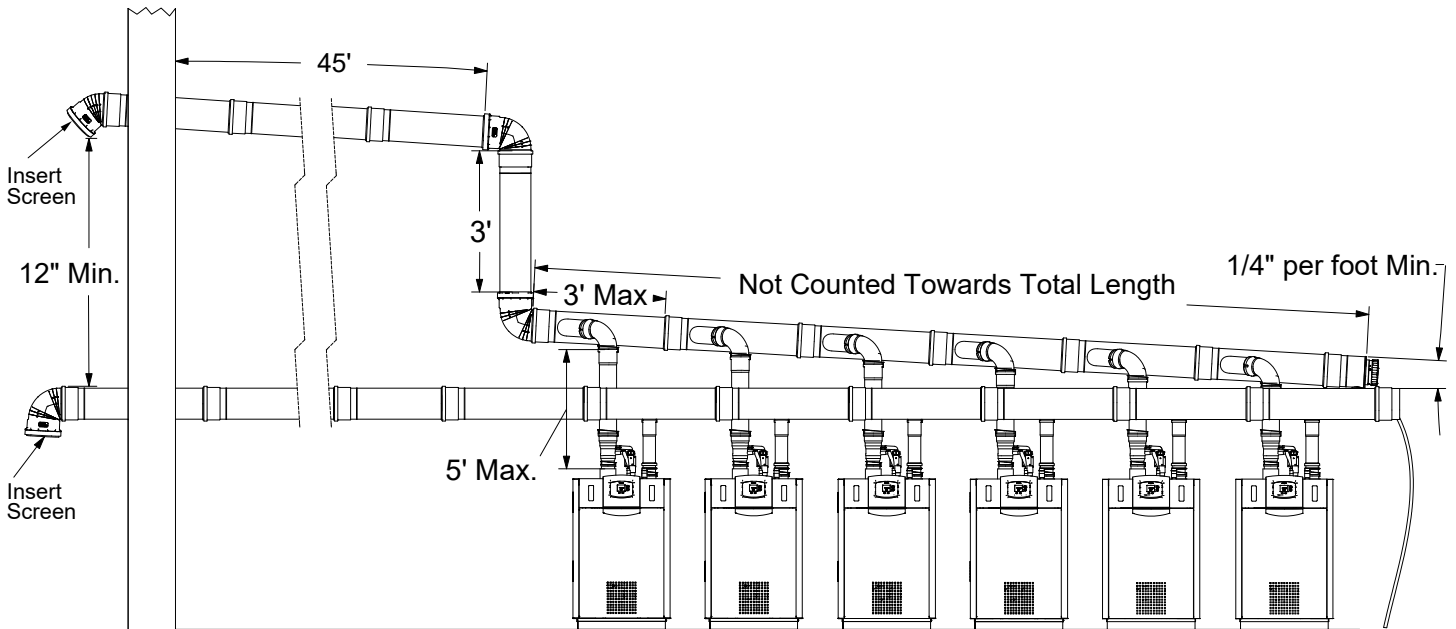

In the example system above, 6 BNTH210 modulating boilers are to be installed with a common vent.

1. Assuming equivalent vent lengths of 8 feet for an 87° elbow and 3 feet for a 45° elbow, the total equivalent length is  $3+45+8+8+3=67$  feet.
2. Using table 8, an 8-inch diameter trunk size is selected.

## 2.E Installation

All units in a common vent system must be properly installed according to the Brute Installation and Operation Manual as well as all applicable building codes.

All venting must be properly assembled per the venting manufacturer's instructions. For Centrotherm InnoFlue, reference the InnoFlue Installation Guide available on Centrotherm's website:

<http://www.centrotherm.us.com/Literature.aspx>.

Additionally:

1. Only the materials listed in section 2.A may be used for a common vent system. Centrotherm InnoFlue polypropylene vent material must be used on the exhaust. If PVC, CPVC, or ABS material is to be used on the air intake, the nominal trunk diameter must match that of the nominal exhaust trunk diameter. All joints must be properly sealed.
2. A Non-Return Valve must be properly installed on each unit in the correct orientation (vertically).
3. Both the exhaust and air intake must be directly vented to the outside of the building. Using room air for a common vent system is not permitted.
4. All vent piping must be properly supported. Do not allow the units to support the weight of the venting.
5. Horizontal portions of the exhaust vent must be sloped at least  $\frac{1}{4}$  inch per foot back toward the boiler to allow condensate to drain out of the vent. Consult local codes for the proper disposal method for the condensate.

### CAUTION

Condensate is mildly acidic (pH = 5), and may harm some floor drains and/or pipes, particularly those that are metal. Ensure that the drain, drainpipe and anything that will come in contact with the condensate can withstand the acidity, or neutralize the condensate before disposal.

6. Screens with mesh size no greater than  $\frac{1}{2}$  inch must be installed on each termination (air intake & exhaust) to prevent debris from entering the vent system.
7. Follow all local and national codes in regards to proper vent termination clearances. Side wall exhaust vent terminations must be at least 12 inches above the top of the air intake terminations and be horizontally separated by at least 84 inches.

Once the vent has been installed, power on each unit in the common vent system. Confirm normal operation and verify that there is no exhaust or condensate leakage from any connection.

## SECTION 3 Maintenance

Perform all regular maintenance required by each unit as stated in the Installation and Operation Manual.

Additionally, perform the following steps at least once per year:

1. Visually inspect each Non-Return Valve to make sure that both the valve and ball check siphon are free from debris and operating correctly. If debris is noticed inside either, remove the Non-Return Valve from the vent system to clean. Once the valve has been cleaned, and correct operation re-established, re-assemble the valve into the vent system.
2. Check the air intake and exhaust vent terminations and verify that they are both free from debris or any obstructions.
3. Inspect the exhaust and air intake vents to ensure that all joints are sealed properly. If any joints need to be resealed, completely remove any existing sealing material, clean the joint, and reassemble.

Replace the Non-Return Valve with a new one when replacing the boiler or water heater.

