

SIDEWALL POWER VENTER KIT

Model: SWGII-5,6, AGA, and SWG-8*

FOR COMMERCIAL WATER HEATERS

* Patented

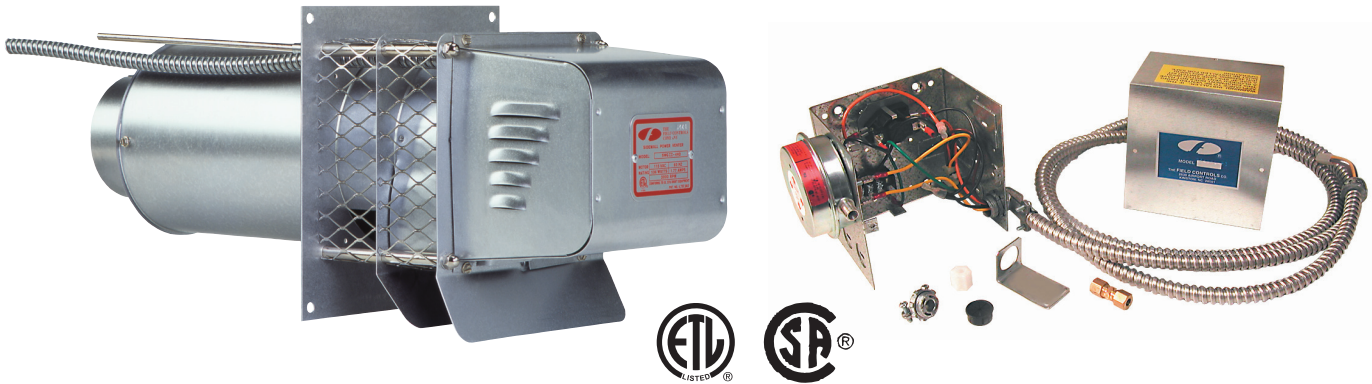

TYPICAL VENTING SYSTEM COMPONENTS

PART NUMBER	DESCRIPTION	APPLICATION
239-81764-00	SWGII-5 Power Venter, CK-41 24 Volt Control Kit	Commercial Water Heaters With 24 Volt Controls With Input Ratings Of Up To 290,000 BTU/HR
239-81765-00	SWGII-5 Power Venter, CK-81 Millivolt Control Kit	Commercial Water Heaters With Millivolt Controls With Input Ratings Of Up To 290,000 BTU/HR
239-81766-00	SWGII-6 Power Venter, CK-41 24 Volt Control Kit	Commercial Water Heaters With 24 Volt Controls With Input Ratings Greater Than 290,000 BTU/HR And Up To 416,000 BTU/HR
239-81767-00	SWGII-6 Power Venter, CK-81 Millivolt Control Kit	Commercial Water Heaters With Millivolt Controls With Input Ratings Greater Than 290,000 BTU/HR And Up To 416,000 BTU/HR
239-82148-00	SWG-8 Power Venter, CK-41 24 Volt Control Kit	Commercial Water Heaters With 24 Volt Controls With Input Ratings Greater Than 415,000 BTU/HR

READ THESE INSTRUCTIONS CAREFULLY AND COMPLETELY BEFORE PROCEEDING WITH THE INSTALLATION.

This device **MUST** be installed by a qualified agency in accordance with the manufacturer's installation instructions. The definition of a qualified agency is: any individual, firm, corporation or company which either in person or through a representative is engaged in, and is responsible for, the installation and operation of HVAC appliances, who is experienced in such work, familiar with all the precautions required, and has complied with all the requirements of the authority having jurisdiction.

Please retain these instructions after installation.

Installed By: _____ Phone: _____ Installation Date: _____



FIELD CONTROLS

www.fieldcontrols.com

ITEMS INCLUDED IN KIT (CK-41):

- 1- Junction box with mounted pressure switch and relay base
- 1- 24 volt relay for controlling power venter motor
- 1- 1 ft. length of ¼" aluminum tubing
- 1- ¼" tubing connector
- 1- flexible metal clad conduit
- 1- GSK-3 spillage switch
- 1- wiring harness (30 ft. length) to connect power venter control to water heater controls
- 3- cable clamps to fasten the harness

ITEMS INCLUDED IN KIT (CK-81):

- 1- Junction box with mounted pressure switch
- 1- 115V to 24V transformer
- 1- 24 volt relay
- 1- 1 ft. length of ¼" aluminum tubing
- 1- ¼" tubing connector
- 1- flexible metal clad conduit
- 1- GSK-3 spillage switch
- 1- wiring harness (30 ft. length) to connect power venter control to water heater controls
- 3- cable clamps to fasten the harness

GENERAL SYSTEM OPERATION**POWER VENTER KITS FOR 24 VOLT CONTROLS (CK-41 CONTROL KIT)**

1. The water heater aquastat contacts close and the flue damper (if part of water heater) opens. When the damper opens all the way, the end switch contacts in the damper motor close, completing the 24 volt circuit to the CK-41 control box causing the motor relay contacts to close and start the power venter motor.
2. When the power venter blower reaches operating speed, the resulting vacuum causes the pressure switch contacts to close. The 24 volt control circuit flows through the pressure switch contacts in the CK-41 control box and through the normally closed spillage switch contacts on the draft hood, completing the circuit to the ignition module on the water heater control box. The ignitor lights the pilot and the main gas valve opens causing the main burners to light.
3. If the venting system becomes disconnected or plugged between the power venter and the water heater vent connection, the flue products will spill out of the draft hood relief opening, heat up the spill switch temperature disc and cause the contacts to open and interrupt power to the ignition module causing the gas valve to close and stop the burners. If the power venter blower fails to operate, the pressure switch contacts will not close and the burners remain off.
4. When the aquastat is satisfied, the contacts open and stop the power venter, interrupting power to the ignition module and gas valve, and the flue damper closes.

POWER VENTER KIT FOR MILLIVOLT CONTROLS (CK-81 CONTROL KIT)

1. When the aquastat contacts close, the 24 volt circuit is completed from the transformer, through the wiring harness and switch contacts, and through the relay coil causing the motor relay contacts to close and start the power venter blower.
2. When the blower reaches operating speed, the vacuum near the blower causes the pressure switch contacts to close and complete the millivolt circuit through the normally closed spill switch contacts to the gas valve, allowing main gas to flow to the burners and ignite from the pilot.
3. If the venting system becomes disconnected or plugged between the power venter and the water heater vent connection, the flue products will spill out of the draft hood relief opening, heat up the spill switch temperature disc and cause the contacts to open and interrupt the millivolt circuit to the gas valve and stop all gas flow. If the power venter blower fails to operate, the pressure switch contacts will not close and the burners remain off. If the pilot becomes extinguished, the thermopile stops generating millivolt power and the gas valves remain closed until the pilot is relit.
4. When the aquastat is satisfied, the contacts open and stop the power venter, causing the power to be interrupted to the ignition module and gas valve, and the flue damper closes.

INSTALLATION SAFETY INSTRUCTIONS

CAUTION: This device must be installed by a qualified installer in accordance with the manufacturer's installation instructions. Appliances should have a minimum of 75% combustion efficiency or have a maximum measured flue gas temperature of 550°F at the inlet of the power venter.

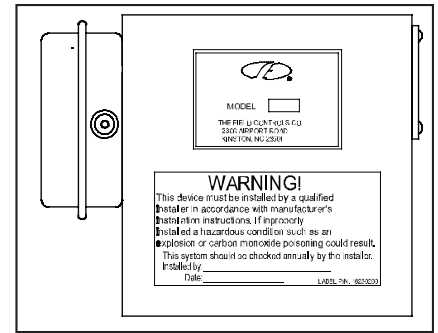

Figure 1

1. The power venting system must be installed by a qualified installer. "Qualified Installer" shall mean an individual who has been properly trained or is a licensed installer. The installer must write or imprint his name, phone number, and date of installation on the installation tag. The tag should be attached to the system control kit box or power venter unit. Also, the included adhesive "Warning!" label should be attached to the Control Kit box, as shown in Figure 1, and the installers name be written on it. Recording burner and venting system initial operational information is strongly recommended as a guide for service or burner tune-up. Enter this on the back page of this manual. The appropriate wiring diagram for the type of controls on the water heater must be affixed to the water heater jacket upon completion of the installation.
2. Safety inspection of a venting system should be performed before and after installing a power venting system on an existing or new appliance. Procedures to follow are those recommended by the National Fuel Gas Code, ANSI Z223.1, or refer to General Installation Inspection section of this manual.
3. Plan the vent system layout before installation to avoid the possibility of accidental contact with concealed wiring or plumbing inside walls.
4. Single wall vent pipe (refer to Diagram B) may be used to join an appliance to the venting system, but if proper clearances cannot be maintained from combustibles materials, Class B Vent Pipe should be used. Refer to national or local codes for guidelines.
5. Disconnect power supply before making wiring connections to prevent electrical shock and equipment damage.
6. This equipment is designed to overcome minor negative pressure conditions. To ensure extreme negative pressure does not exist, follow General Installation Inspection of this manual.
7. The commercial water heaters for the SWGII-5 and 6 power venters have draft hoods, and each kit includes a GSK-3 spillage switch which must be installed on the bottom of the draft hood to detect spillage of flue products due to inadequate venting draft or vent system blockage. In the event of excessive flue spillage from the draft hood, the spillage switch will interrupt power to the gas valve to stop the burners. Refer to the installation instructions for the spillage switch in the Installation section of these instructions.
8. The power venter must be installed downstream of the appliance draft hood.

INSTALLATION OF SWG POWER VENTER

UNIT SIZE CHART				
MAXIMUM BTU/ HR INPUT*	MAX. EQUIVALENT FEET OF VENT PIPE		VENTING WITH VENT PIPE SIZE	MODEL NUMBER
	AT MAXIMUM INPUT	AT 60% OF MAXIMUM INPUT		
290,000	16	44	4"	SWGII-5
	51	100	5"	
	95	100	6"	
416,000	28	78	5"	SWGII-6
	68	100	6"	
	100	100	7"	
505,000	65	65	10"	SWG-8

*Do not exceed maximum BTU/HR input rating.

PROCEDURE FOR CALCULATING TOTAL EQUIVALENT PIPE LENGTH IN FEET

1. Calculate the total equivalent feet for each type of fitting used in the venting system from the chart below.
2. Calculate the total amount of feet for the straight lengths of vent pipe.
3. Add the equivalent feet for the fittings with the total amount of feet of straight lengths. This will approximate the total equivalent feet of the vent system.

EQUIVALENT LENGTH (FEET) OF VENT PIPE								
VENT PIPE FITTINGS	VENT PIPE DIAMETER							
	3"	4"	5"	6"	7"	8"	9"	10"
TEE	19	25	31	38	44	50	56	63
90° ELBOW	5	7	9	11	12	14	16	18
45° ELBOW	3	4	4	5	6	7	8	9
SUDDEN REDUCER OR INCREASER FOR THREE RATIOS* (d/D)	d/D							
	1/4	8	11	14	17	19	22	25
	1/2	5	7	8	10	12	13	15
	3/4	2	3	3	4	4	5	6

*Reducer or increaser ratio (d/D) small diameter divided by the larger diameter. (See Figure 2) Example 4" to 8" reducer: The reducer ratio is $d/D = \frac{4}{8} = \frac{1}{2}$. To estimate the equivalent foot length for the fitting, use the smaller pipe diameter for the equivalent length figure. Example 4" to 8" reducer; the reducer ratio is $\frac{1}{2}$ and the smaller pipe diameter is 4". So, from the chart, the equivalent feet would be 7 feet.

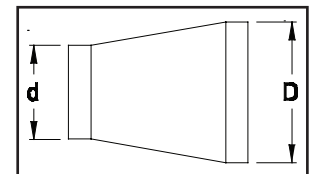

Figure 2

Example 1: System Pipe Size = 4"

- Step 1 Two 4" 90° Elbows @ 7 feet each = 14 Ft.
 Step 2 Ten 2 Foot Lengths of 4" Pipe = 20 Ft.
 Step 3 Total Equivalent Feet = 14 Ft. + 20 Ft. = 34 Ft.

Example 2: System Pipe Size = 10"

- Step 1 Fifteen 2 Foot Lengths of 10" Pipe = 30 Ft.
 Step 2 One 10" 90° Elbow = 18 Ft.
 Step 3 One 8" to 10" Reducer (Use $\frac{3}{4}$) = 5 Ft.
 Step 4 Total Equivalent Feet = 30 Ft. + 18 Ft. + 5 Ft. = 53 Ft.

CAUTION: Failure to install, maintain, and/or operate the power venting system in accordance with manufacturer's instructions will result in conditions which may produce bodily injury and/or property damage.

1. Remove power venter from box and inspect unit for damage. If the carton has been crushed or mutilated, check unit very carefully for damage. Rotate blower wheel to insure that the motor and blower wheel rotate freely. DO NOT install if any damage is apparent. Refer to unit sizing chart to check proper venting sizing.
2. Location of the termination of the venting system should be installed in accordance with the National Fuel Gas Code, ANSI Z223.1, and/or manufacturer's recommendations which are applicable. See requirements below or refer to installation location Diagram A for typical locations.
 - a. The exit termination of mechanical draft systems shall not be less than 7' above grade when located adjacent to public walkways.
 - b. A venting system shall terminate at least 3' above any forced air inlet located within 10'.
 - c. The venting system of other than a direct vent appliance shall terminate at least 4' below, 4' horizontally from, or 1' above any door, window or gravity air inlet into the building.
 - d. The vent termination of a direct vent appliance with an input of 50,000 BTUs per hour or less, shall be located At least 9" from any opening through which vented gases could enter the building. With an input over 50,000 BTUs per hour, a 12" termination clearance shall be required.
 - e. The vent termination point shall not be installed closer than 3' from an inside corner of an L-shaped structure.
 - f. The vent termination should not be mounted directly above, or within 3' horizontally from an oil tank vent or gas meter.
 - g. The bottom of the vent terminal shall be located at least 12" above finished grade.

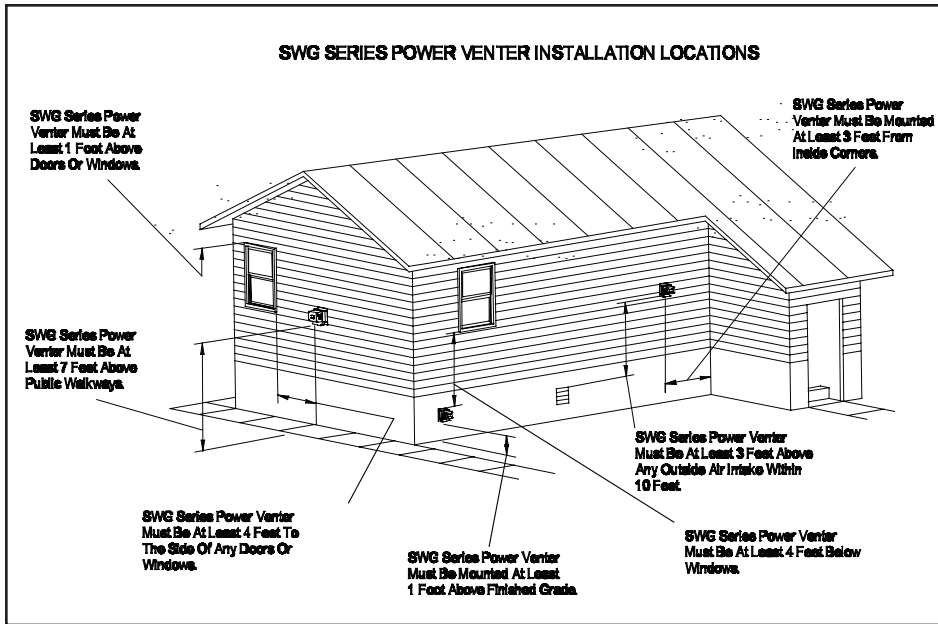

Diagram A

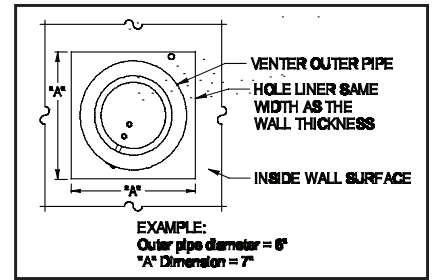

Figure 3

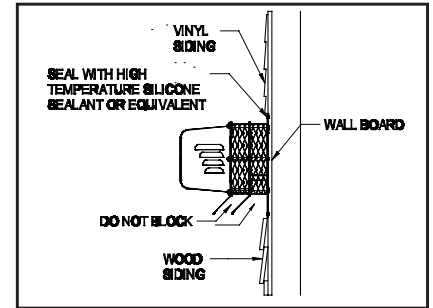

Figure 4

- After determining the location of the venting system termination point (See Diagram A), cut a square hole through the wall 1" larger than the outer pipe diameter of the power venter. Mount the power venter through the wall, keeping the outer pipe centered in the hole. (See Figure 3) Fasten the power venter to the outside wall with appropriate fasteners. Seal the edges of the power venter base plate to the wall with a high temperature silicone sealant. DO NOT enclose the spaced plates on the power venter body. This will result in reduced cooling of the power venter body. Galvanized metal sheets may be installed over surrounding building surfaces to protect building materials from degradation by flue gases. Brick or tile may be placed on the ground below the power venter to protect the soil and vegetation from the effects of heated exhaust air. The power venter should be placed so that vegetation and other objects are not in direct contact with the power venter or blocking the outlet. Snow should be cleared from the outlet area as needed. Wood or vinyl siding should be cut so that the unit mounts directly on the wall board to provide a stable support. If the siding is greater than 1/2" thick use a spacer plate or board behind the power venter mounting plate. (See Figure 4)

NOTE: If mounting the power venter through a combustible wall material and the flue gas temperature is above 400°F at the power venter inlet, line the square hole with a piece of corrosion resistant sheet metal or non-combustible material. The liner piece should be the same width as the wall section. (See Figure 3) The power venter has maximum flue gas temperature of 550°F at the power venter inlet. Figure 7 shows how the airflow pattern through an SWG reduces the required clearances to combustibles. For installation in wall thickness over 8", use an SWG Series Through Wall Extension Kit, Model PEK.

- Remove the end pipe cover screws on the sides of the outside pipe and remove end pipe cover. Then mount the backing plate over the outer pipe and route the flexible conduit and pressure switch tube through the holes provided in the backing plate. Fasten the backing plate to the inside wall with appropriate fasteners. (See Figure 5) Re-install end pipe cover and screws.

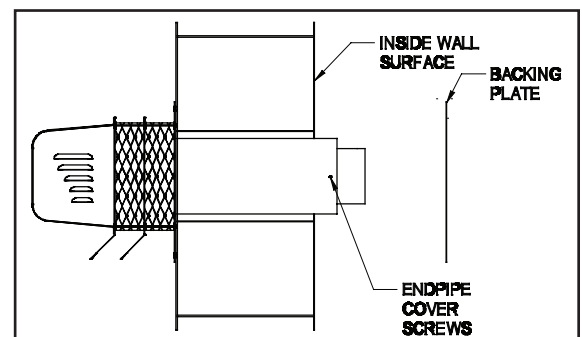

Figure 5

CONNECTING POWER VENTER TO APPLIANCE

Venting system should be installed and supported in accordance with the National Fuel Gas Code ANSI Z223.1, or in accordance with any local codes. A vent pipe connector shall be supported for the design and weight of the material employed, to maintain clearances, prevent physical damage and separation of joints. A vent pipe increaser or reducer may be required for connecting the power venter to the vent system. If needed, place the reducer close to the power venter. Smaller vent pipe sizes than a chimney-vented system may be used for the vent system.

If mounting venting system near combustible materials, refer to Diagram B for allowable installation clearances. Clearances are based on an installation using single wall galvanized steel vent pipe. For metal thickness of galvanized steel pipe connectors, refer to NFPA 211 or NFPA 54 Standards for guidelines. If manufactured double wall vent pipe is required or used for the installation, clearance should be based on the vent pipe's rated clearance. Always check local code requirements for code restrictions.

Route the vent pipe from the appliance to the power venter using as few elbows as possible. The horizontal section of the vent pipe should have a slight upward slope from the appliance to the power venter. For clearances to combustible materials, multiple appliance venting and other installation requirements, refer to the National Fuel Gas Code ANSI Z223.1, and/or any applicable local codes or appliance manufacturer's installation instructions.

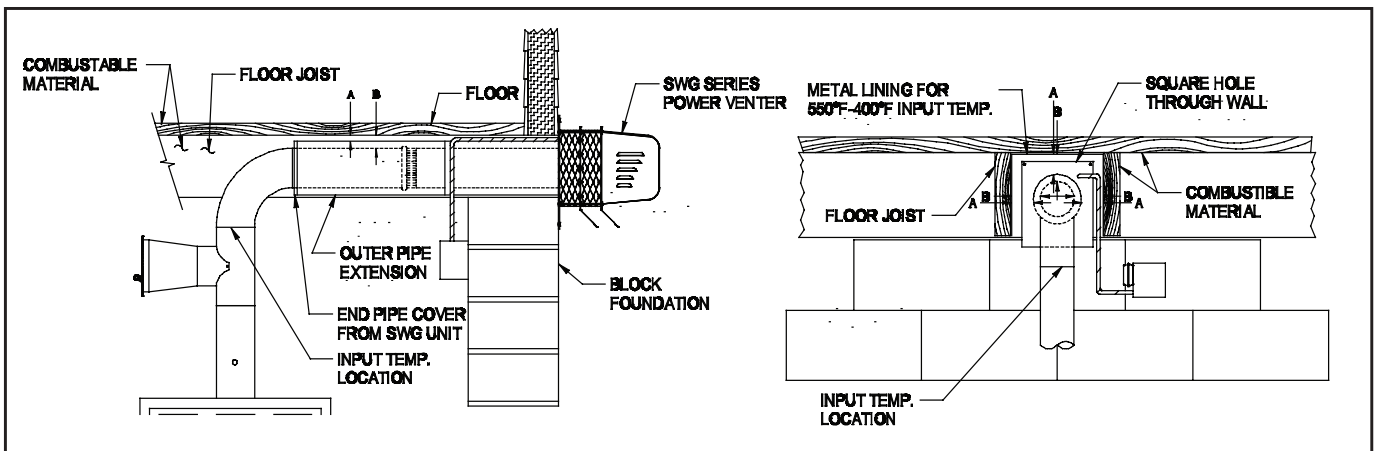

Diagram B

INSTALLATION USING SINGLE WALL VENT PIPE

INSTALLATION CLEARANCE WITH SINGLE WALL VENT PIPE			
DOUBLE PIPE SYSTEM		SINGLE PIPE SYSTEM	
ALLOWABLE INLET TEMPERATURE	CLEARANCE (A)	ALLOWABLE INLET TEMPERATURE	CLEARANCE (B)
400°F Or Less	½" Minimum	400°F Or Less	3" Minimum
400°F To 550°F	1" Minimum	400°F To 550°F	4" Minimum
400°F To 550°F	½" Minimum With Sheet Metal Liner	400°F To 550°F	3" Minimum With Sheet Metal Liner

To install an outer pipe extension to the SWG power venter, the end pipe cover on the power venter must be removed. Then, cut a 1" square notch into the vent pipe extension before attaching to the power venter. (See Figure 6) This allows clearance for the adjustment damper. Install the required length of outer pipe extension lengths as needed for clearance to combustible materials. Terminate the outer pipe extension with the end pipe cover. (See Diagram B) The table shows minimum allowable clearances when using single or double pipe systems. When the outer pipe is extended over the inner pipe use the double pipe guidelines when determining clearances.

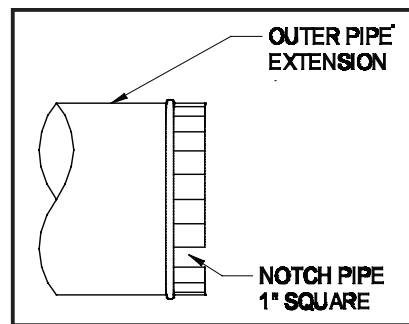

Figure 6

NOTE: Vent pipe joints should be secured with at least three (3) sheet metal screws.

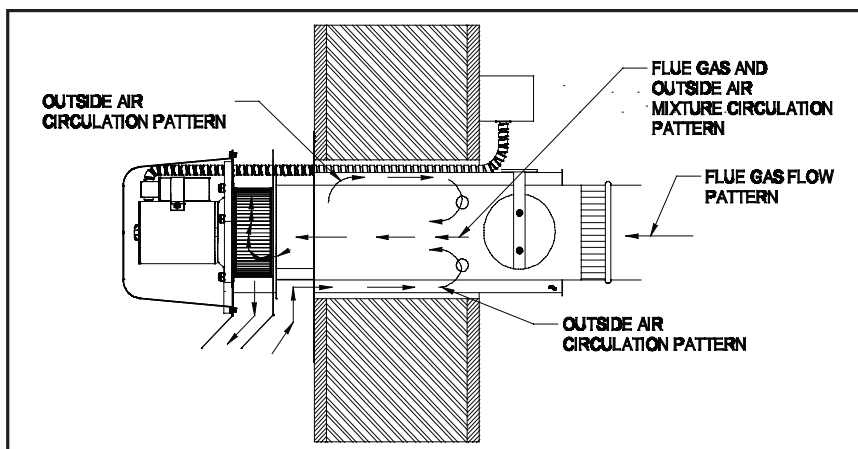

Figure 7

CLASS B AND CLASS L DOUBLE WALL VENT PIPE INSTALLATION

(Follow vent pipe manufacturer's listed or recommended clearances from combustible material.)

1. Using a hand crimper or a like device, crimp the inner pipe of the SWG power venter approximately 1" long. (See Figure 8)
2. Attach the vent pipe over the crimped end of the SWG power venter inner pipe.
3. Secure the vent pipe to the SWG power venter inner pipe with at least three (3) #8 sheet metal screws. Pre-drilling the holes through both pipes will allow easier fastening.

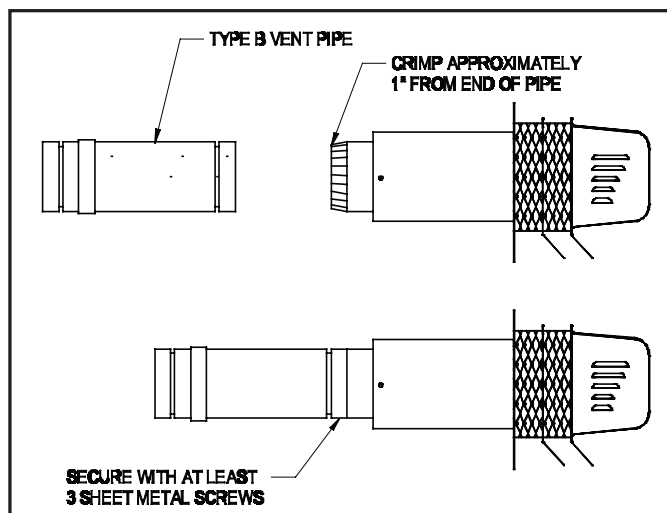

Figure 8

WIRING INSTRUCTIONS

NOTE: Refer to the appropriate wiring diagrams contained in these instructions for the corresponding control system for the water heater being installed.

Wire the power venter motor and controls in accordance with the National Electrical Code and applicable local codes. UNIT MUST BE GROUNDED. Check ground circuit to make certain that the unit has been properly grounded. The wiring should be protected by an over-current circuit device rated at 15 amperes. CAUTION MUST be taken to ensure that the wiring does not come in contact with any heat source. All line voltage and safety control circuits, between the power venter and the appliance, MUST be wired in accordance with the National Electrical Code for Class 1 wiring or equivalent.

CK-41 CONTROL KIT WIRING FOR 24 VOLT WATER HEATER CONTROLS

1. Remove the wiring harness supplied with the control kit.
2. Remove the upper left knockout of the control box. Push the snap bushing supplied over the knockout hole created to prevent the wires from being chafed. Insert the end of the harness with quick connect terminals into the side of the control box.
3. Disconnect the black wire connected to TH or 24V on the ignition module and connect to the fully insulated tab on the black wire from the wiring harness provided.
4. Connect the yellow wire from the harness supplied to the TH or 24V terminal on the ignition module.
5. Connect the red wire from the harness supplied to the upper terminal block (the group of terminals opposite the yellow wire leading to the thermostat).
6. Run the harness supplied along the water heater jacket and support with the clamps provided. (See Figure 9)
7. Install the GSK-3 spillage switch on the draft hood with the self-tapping sheet metal screw supplied. The thermal element disc should hang just below the draft hood relief opening. (See Figure 10)
8. Run the two (2) yellow wires from the break in the top of the wiring harness into the spillage switch through the plastic bushing opening and connect to the switch terminals.
9. Run the harness to the CK-41 junction box, which will be mounted in a convenient location near the power vent. Use clamps to support the wire harness to the joists at regular intervals to prevent sagging.
10. Run the low voltage wires into the control box (through hole with plastic bushing) and connect the wires as follows:
 Connect the black wire to terminal T1, the red wire to T2, and the yellow wire to T3.
 (See Figures 13 and 14)
11. Follow the National Electrical Code and/or applicable local codes for running high voltage wires to the CK-41 control box and wire according to the diagram. Unit must be grounded. Check ground circuit to make sure the unit has been properly grounded. Connect the flexible conduit from the blower to the control box and wire according to the diagram.
12. Attach the appropriate self-adhesive wiring diagram label to the water heater jacket.

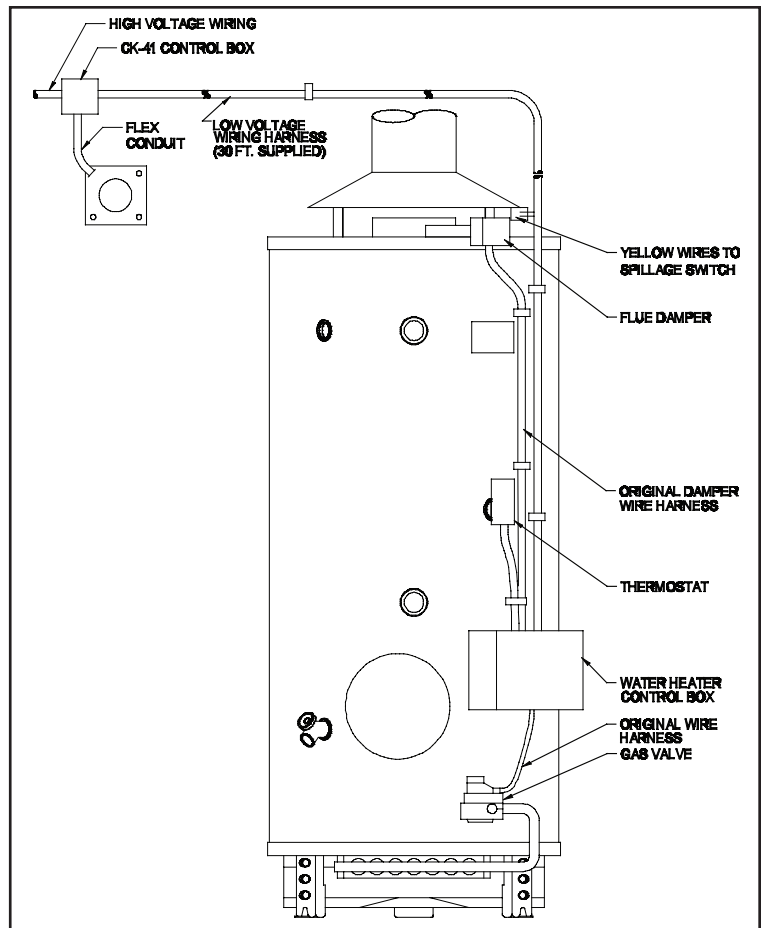

Figure 9

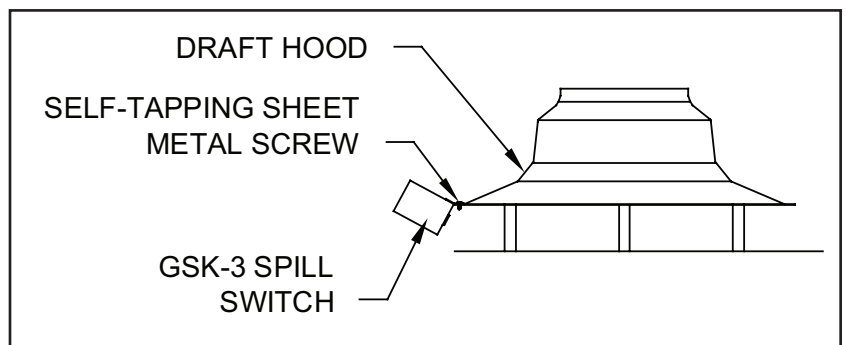

Figure 10

CK-41 CONTROL KIT WIRING FOR 24 VOLT WATER HEATER CONTROLS WITH HONEYWELL INTEGRATED CONTROL

1. Remove the wiring harness supplied with the control kit.
2. Remove the upper left snap-in plug of the control box. Push the snap bushing supplied into the hole to prevent the wires from being chafed. Remove the quick connect terminals and strip the insulation approximately $\frac{1}{2}$ ". Insert that end of the harness into the top of the control box.

Make all wire connections inside water heater control box.

3. Cut white wire approximately 8" from damper harness plug (terminal 4) and wire nut all three wires (white, red, white) together creating a parallel circuit.
4. Cut black wire approximately 8" from damper harness plug (terminal 2) and wire nut black wire from DAMPER HARNESS to black wire from Power Venter.
5. Wire nut yellow wire from Power Venter to black wire from DAMPER PLUG on control board.
6. Run the harness supplied along the water heater jacket and support with the clamps provided. (See Figure 11)
7. Install the GSK-3 spillage switch on the draft hood with the self tapping sheet metal screw supplied. The thermal element disc should hang just below the draft hood relief opening. (See Figure 10)
8. Run the two (2) yellow wires from the break in the top of the wiring harness into the spillage switch through the plastic bushing opening and connect to the switch terminals.

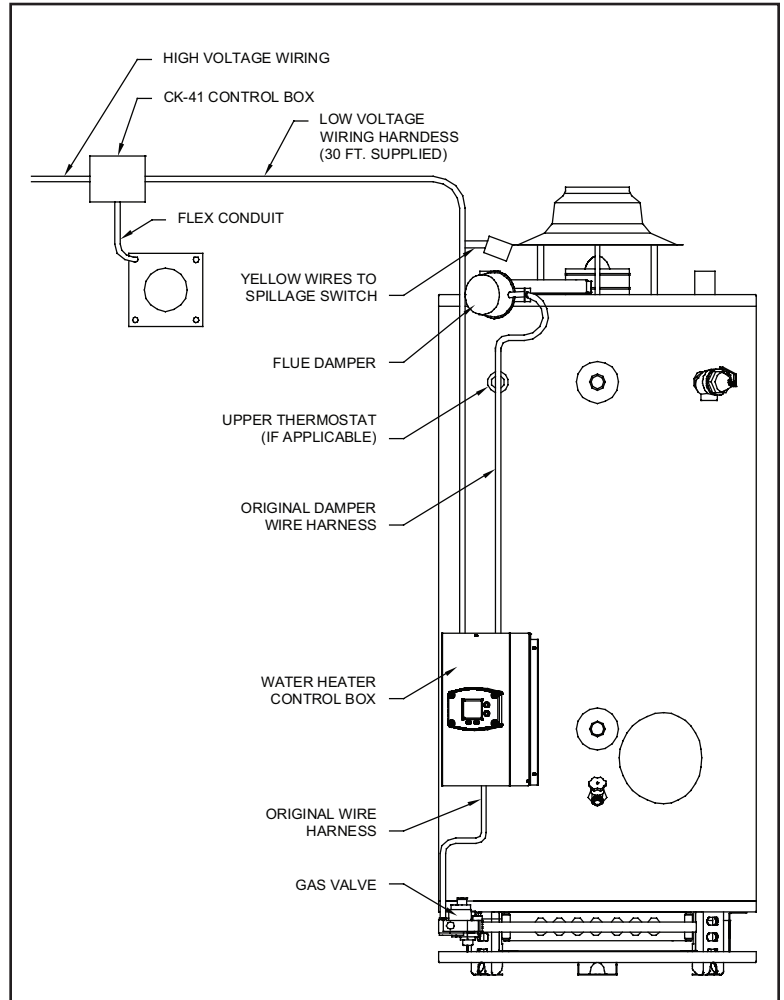
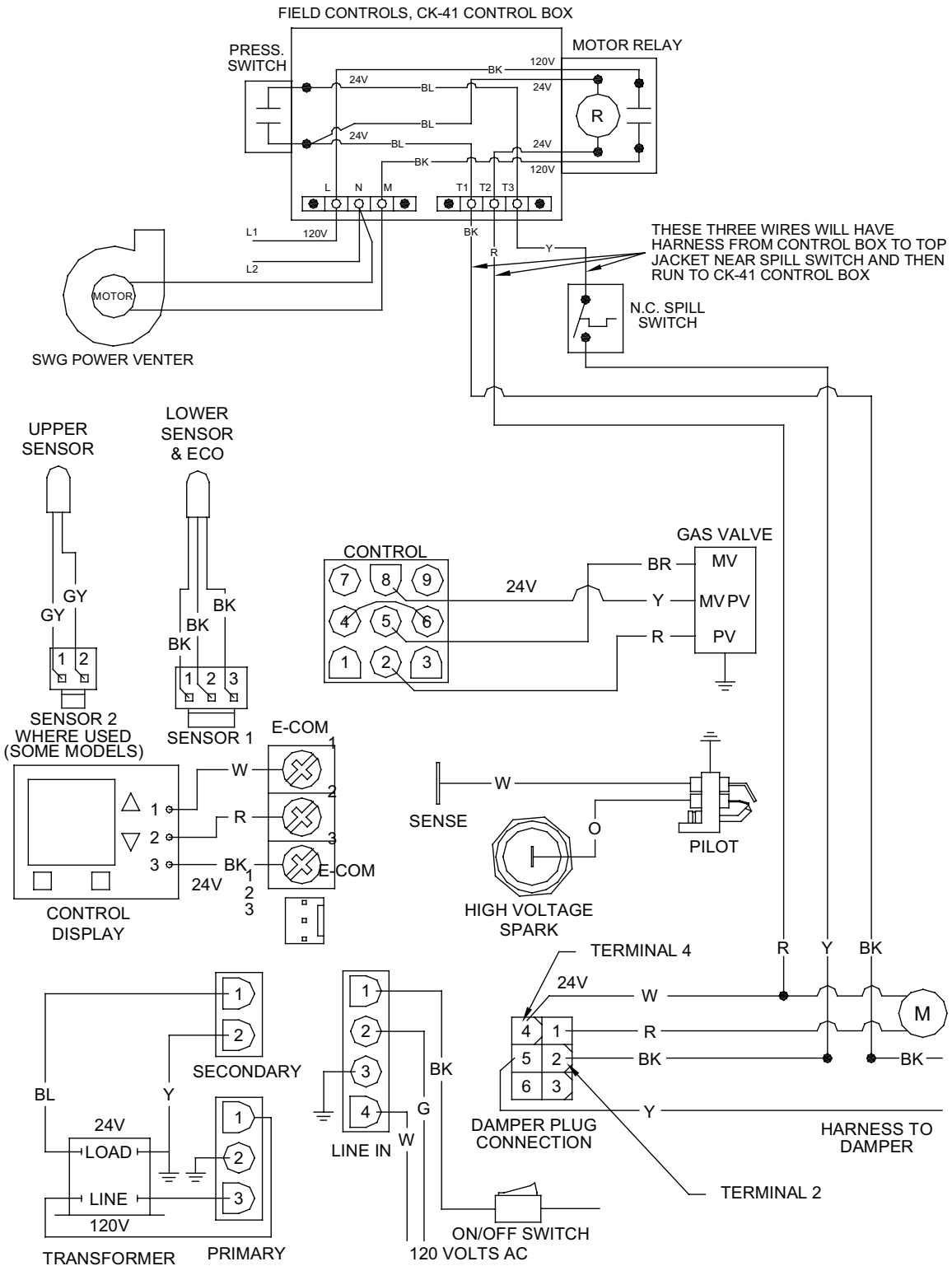

Figure 11

9. Run the harness to the CK-41 junction box, which will be mounted in a convenient location near the Power Venter. Use clamps to support the wire harness to the joists at regular intervals to prevent sagging.
10. Remove knock out from the side of the Power Venter control box and insert snap bushing provided to prevent the wires from being chafed. Run the low voltage wires into the hole just created on the side of the Power Venter control box and connect the wires as follows:
Connect the black wire to terminal T1, the red wire to T2, and the yellow wire to T3. (See Figure 12)
11. Follow the National Electrical Code and or applicable local codes for running high voltage wires to the CK-41 control box and wire according to the diagram. Unit must be grounded. Check ground circuit to make sure the unit has been properly grounded. Connect the flexible conduit from the blower to the control box and wire according to the diagram.
12. Attach the appropriate self-adhesive wiring diagram label to the water heater jacket.

WIRING DIAGRAM

HONEYWELL INTEGRATED CONTROL



NOTE:
 IF ANY OF THE ORIGINAL WIRES AS SUPPLIED WITH THE APPLIANCE MUST BE REPLACED.
 IT MUST BE REPLACED WITH 18 GA STRANDED 105°C WIRE OR ITS EQUIVALENT.

Figure 12

WIRING DIAGRAM

WHITE-RODGERS THERMOSTAT

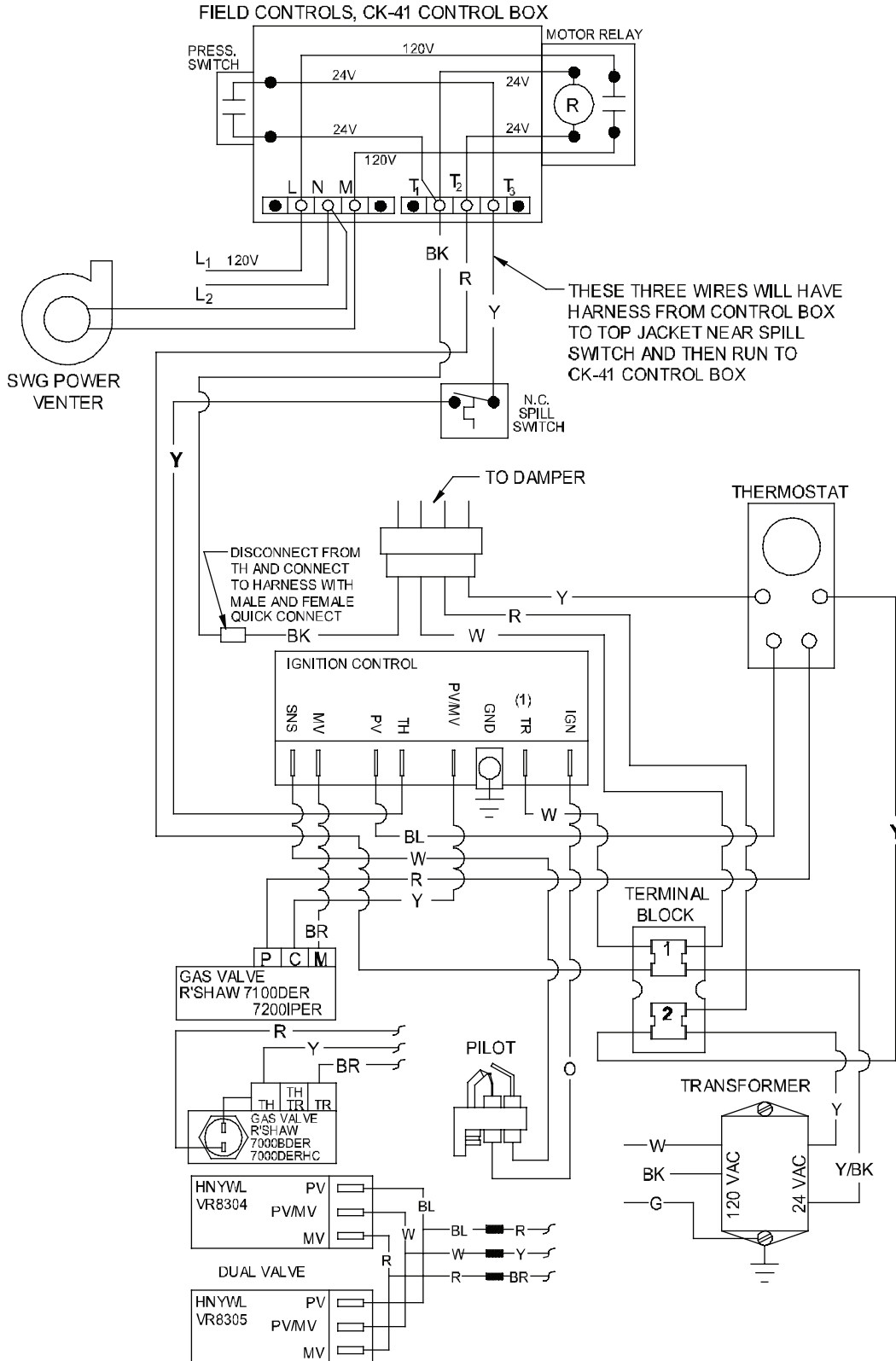

NOTE
 IF ANY OF THE ORIGINAL WIRES AS SUPPLIED WITH THE APPLIANCE MUST BE REPLACED,
 IT MUST BE REPLACED WITH 18 GA. 105° THERMOPLASTIC AWH WIRE OR EQUIVALENT.

Figure 13

WIRING DIAGRAM

HONEYWELL ELECTRONIC THERMOSTAT

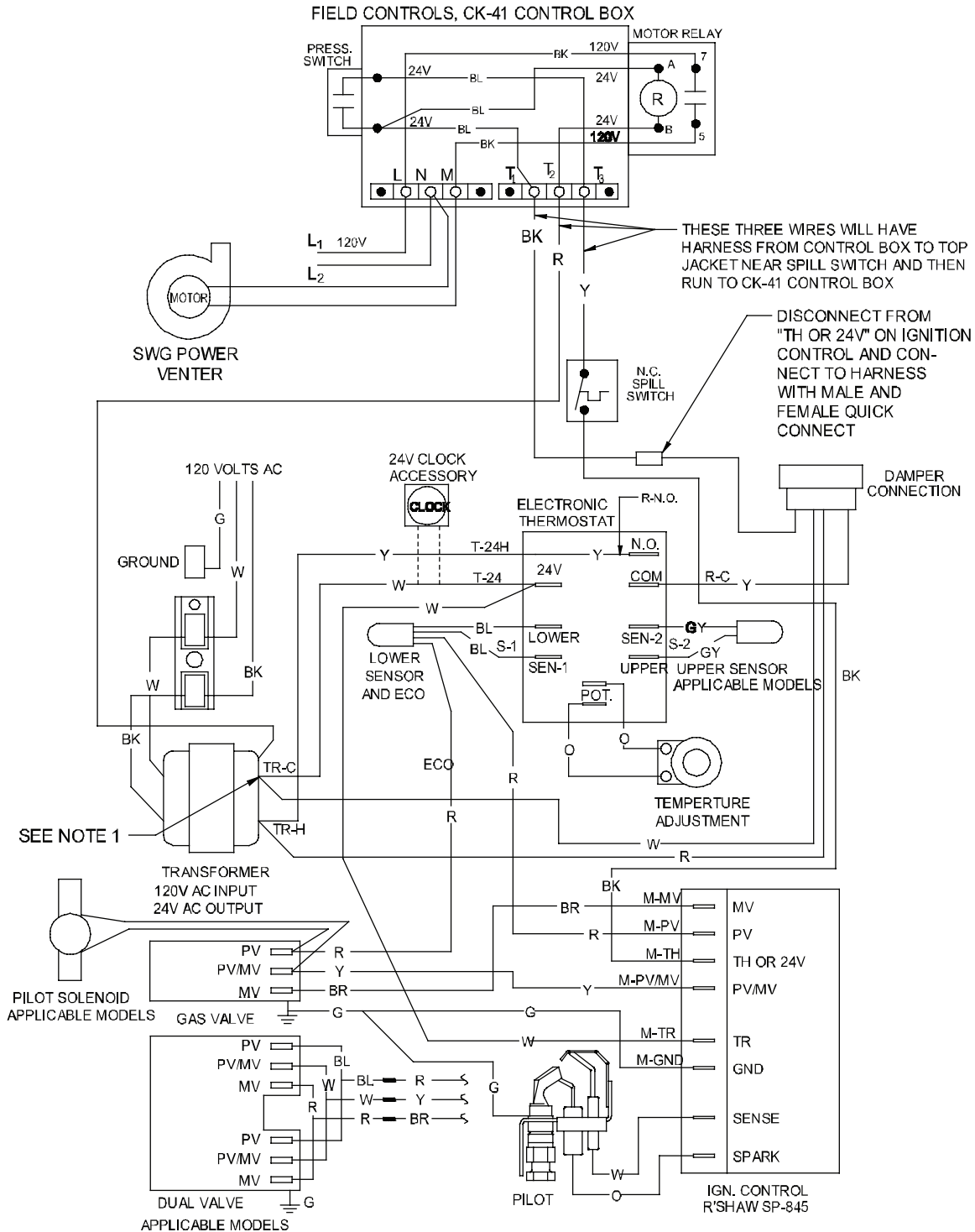

NOTE:

1. REMOVE SCREW AND INSTALL CONNECTOR TO ALLOW CONNECTION OF RED WIRE FROM CK-41.

2. IF ANY OF THE ORIGINAL WIRES AS SUPPLIED WITH THE APPLIANCE MUST BE REPLACED, IT MUST BE REPLACED WITH 18 GA. 105° THERMOPLASTIC AWH WIRE OR EQUIVALENT.

Figure 14

CK-81 CONTROL KIT WIRING FOR MILLIVOLT WATER HEATER CONTROLS

1. Remove wiring harness from control kit box.
2. Remove top knockout from the thermostat. Push the snap bushing supplied over the knockout hole created to prevent the wires from being chafed. Insert wire harness through bushing hole in thermostat top.
3. Disconnect the white and red leads from the thermostat terminals. Reconnect the white wire from the gas valve to terminal #3 (lower left) on the thermostat. Cut the tongue terminal from the end of the red wire to the thermostat and strip $\frac{1}{2}$ " of insulation to expose bare wire. Connect to bare end of red wire from harness using wire nut or crimp butt connector to join wires inside thermostat housing.
4. Connect the black and yellow 24 volt wires from the Harness to the two (2) top terminals of the thermostat.
5. Run the harness supplied along the water heater jacket and support with the clamps provided.
6. Install the GSK-3 spillage switch on the draft hood with the self-tapping sheet metal screw supplied. The thermal element disc should hang just below the draft hood relief opening. (See Figure 10)
7. Run the two (2) red wires from the break in the top of the harness into the spillage switch through the plastic bushing opening and connect to the switch terminals.
8. Run the harness to the CK-81 junction box, which will be mounted in a convenient location near the power venter. Use clamps to support the wire harness to the joists at regular intervals to prevent sagging.
9. Run the harness wires through the hole with the plastic bushing in the control box and connect the wires as follows:
 Connect the black wire to terminal T1, the yellow wire to T2, the blue wire to T3, and the red wire to T4. (See Figure 16)
10. Follow the National Electrical Code and/or applicable local codes for running high voltage wires to the CK-81 control box and wire according to the diagram. Unit must be grounded. Check ground circuit to make sure the unit has been properly grounded. Connect the flexible conduit from the blower to the control box and wire according to the diagram.
11. Attach the appropriate self-adhesive wiring diagram label to the water heater jacket.

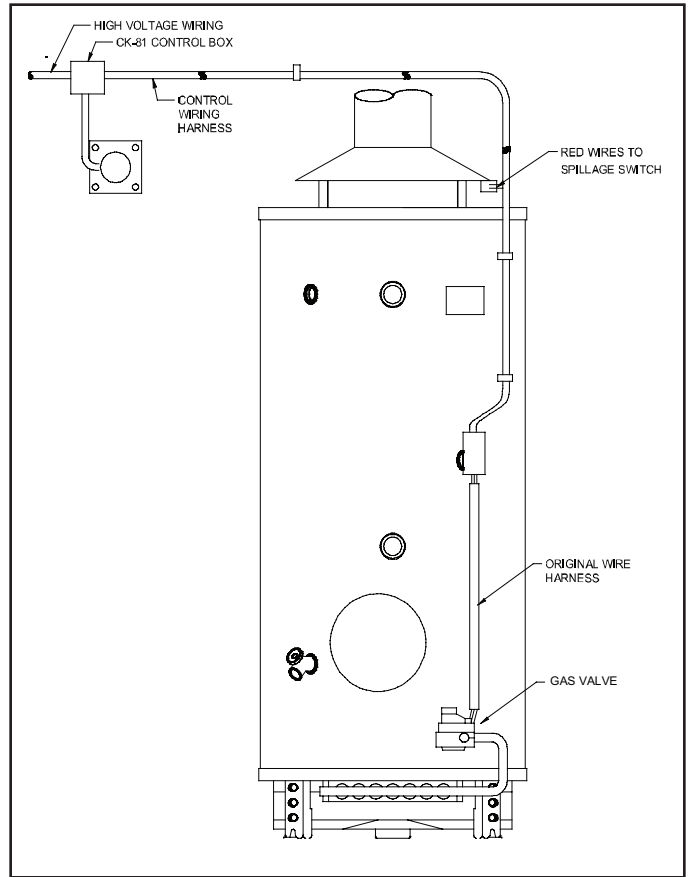

Figure 15

PRESSURE SWITCH ADJUSTMENT

Important: Both the CK-41 and CK-81 power vent control systems have a pressure switch which must be properly set before the water heater can be started. The pressure switches are set so that the contacts will not close until properly set by the installer. Failure to carefully follow the procedure below for setting the pressure switch will either prevent the water heater from operating properly or defeat the safety feature of the control which could allow a hazardous condition to occur in the event the power venter operates with a venting malfunction.

1. Attach the ¼" tubing connector on the pressure tube on the SWG venter. Connect the supplied ¼" aluminum tubing to the tubing connector. Route the tubing to the power venter control box and connect the tubing to the pressure switch. When routing the tubing, avoid kinking the tubing by bending the tubing too sharply.
2. Follow the lighting instructions and light the pilot (millivolt models). Turn thermostat to the highest setting and turn on sufficient water flow to keep the burners on continually. The power venter should start, but the main burners will not come on until the pressure switch is adjusted.
3. Slowly rotate the pressure switch adjustment screw counterclockwise until the contacts close and the burners fire, then rotate the screw ¼ turn counterclockwise. (See Figure 17) Cycle the thermostat a couple of times to ensure proper operation.
4. Follow the General Installation Inspection section to make sure the pressure switch and venting system operates properly with all gas appliances and exhaust fans operating.

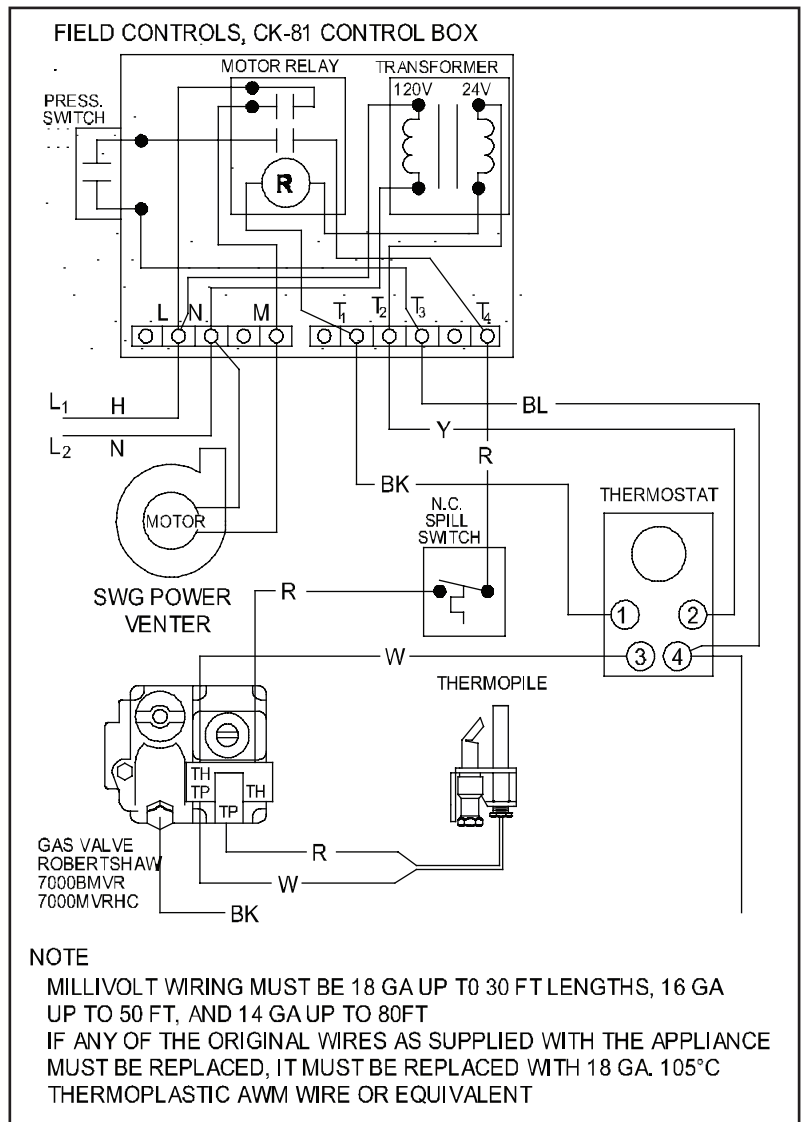

Figure 16

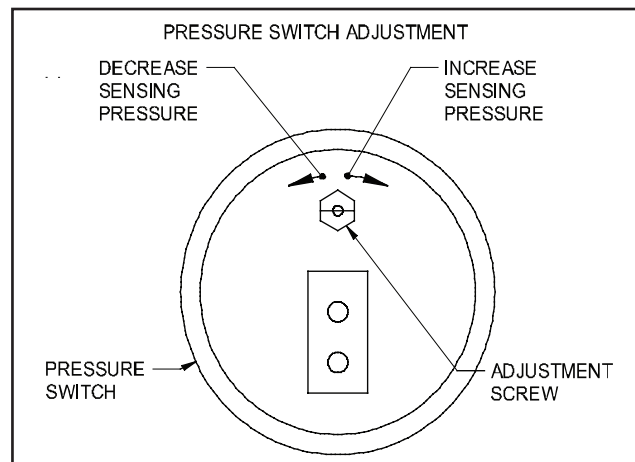

Figure 17

GENERAL INSTALLATION INSPECTION

Recommended procedures for safety inspection of an appliance in accordance with the National Fuel Gas Code ANSI Z223.1. The following procedure will help evaluate the venting system. It is intended as a guide to aid in determining that the venting system is properly installed and is in a safe condition for continuous use. This procedure should be recognized as a generalized procedure which cannot anticipate all situations. Accordingly, in some cases, deviation from this procedure may be necessary to determine safe operation of the equipment. If it is determined that a condition exists which could result in unsafe operation, the appliance should be shut off and the owner advised of the unsafe condition. Corrections must be made before the appliance is put into continuous operation. The following steps should be followed in making a safety inspection.

1. Visually inspect the venting system for proper size and determine that there is no flue gas spillage, blockage, restriction, leakage, corrosion, or other deficiency which could cause an unsafe operation.
2. Insofar as practical, close all building doors, fireplace dampers, windows, and all doors in area in which the appliance is located. Turn on clothes dryers, any exhaust fans, such as range hoods and bathroom exhausters so they operate at maximum speed. Do not operate a summer exhaust fan. If, after completing Steps 3 through 6, it is believed sufficient combustion air is not available, refer to the National Fuel Gas Code ANSI Z223.1, or any applicable local codes for guidance.
3. Place in operation the appliance being inspected. Follow the lighting instructions and adjust thermostat so appliance will operate continuously.
4. Determine that the pilot or burner is operating properly and that the main burner ignition operates satisfactorily, by interrupting and re-establishing the electrical power of the appliance in any convenient manner. Test the pilot or burner safety device to determine if it is operating properly by extinguishing the pilot or disconnecting the flame safety circuit and pressure switch sensing tube from the pressure switch.
5. Visually determine that the main burner is burning properly; i.e., no floating, lifting, or flashbacks.
6. Test for spillage at draft hood opening and burner inlet air location after 5 minutes of main burner operation. Use a draft gauge, flame of a match or candle, smoke from a cigarette, cigar or pipe. If spillage occurs, adequate air is not available. Shut off heating appliance thermostat and check for spillage around the draft hood and burner inlet air location after power venter has stopped operation. If a flow reversal is noticed, house depressurization is occurring and make up air is required.
7. Turn on all fuel burning appliances within the same room so that they will operate at their maximum input. Then repeat Steps 5 through 6.
8. Return doors, windows, exhaust fans, fireplace dampers and any other fuel-burning appliances to their previous condition of use.

MAINTENANCE

NOTE: The installer must notify the owner/user of the device of the maintenance requirements listed below. This instruction sheet must also be left with the owner/user.

1. **Motor:** Inspect the motor once a year - motor should rotate freely. To prolong the life of the motor, it should be lubricated with six drops of SWG Superlube, Part # 46226200, annually.
2. **Wheel:** Inspect the power venter wheel annually to clear any soot, ash or coating which inhibits either rotation or air flow. Remove all foreign materials before operating.
3. **Vent System:** Inspect all vent connections annually for looseness, for evidence of corrosion and for flue gas leakage. Replace, seal, or tighten pipe connections if necessary.
4. **System Safety Devices:** With the heating system operating, disconnect the pressure sensing tube from the pressure switch on the CK Kit. This will stop the burner operation. Re-connecting the tube will relight the burner. For millivolt operating systems, disconnect one lead of the spill switch. This will shut off the pilot and the burner. Re-connection will allow relighting the pilot.

Should the motor or blower wheel need replacing, the following replacement items are available. The Repair Motor Assembly contains the Motor and Blower Wheel factory assembled to a mounting bracket.

FIELD CONTROLS PART NUMBERS		
MODEL	REPAIR MOTOR KIT	BLOWER WHEEL ONLY
SWGII-5	46234900	46150700
SWGII-6	46235000	46154600
SWG-8	46160101	46154800

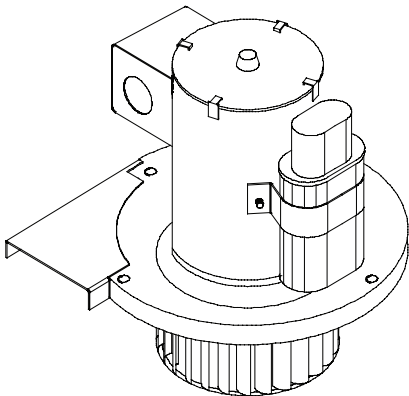

SWGII-5,6 Repair Motor Kit

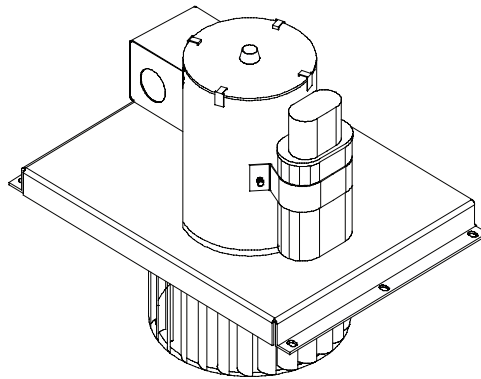

SWG-8 Repair Motor Kit

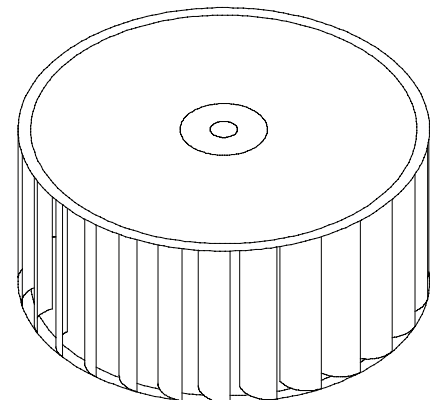

Blower Wheel

REMOVAL AND INSTALLATION OF THE MOTOR ASSEMBLY

REMOVAL

1. Shut down appliance and turn off electrical supply.
2. Remove the motor enclosure cover by loosening the four screws. (See Figure 18)
3. Open the electrical box on the motor and disconnect the conduit and wires from the motor. (See Figure 19)
4. Remove the four nuts securing the motor assembly, and pull the motor assembly straight off of the unit. (See Figure 20)
5. Clean off any build-up inside the blower wheel housing and the blower wheel.

CAUTION: Avoid applying excess pressure on the blower wheel when cleaning off any build-up of material. This will cause an imbalance of the blower wheel which will result in excessive vibration and premature motor failure.

INSTALLATION

1. Align the holes in the circular cover plate with the holes in the motor mount bracket on the motor assembly. (See Figure 19)
2. Slide the motor assembly onto the protruding threaded studs on the venter body with the exhaust chute pointing downward, and replace the four nuts securely to the threaded studs.
3. Reattach the flexible conduit and wires to the motor and secure the cover on the electrical box.
4. Install the motor cover with the side louvers pointing downward.

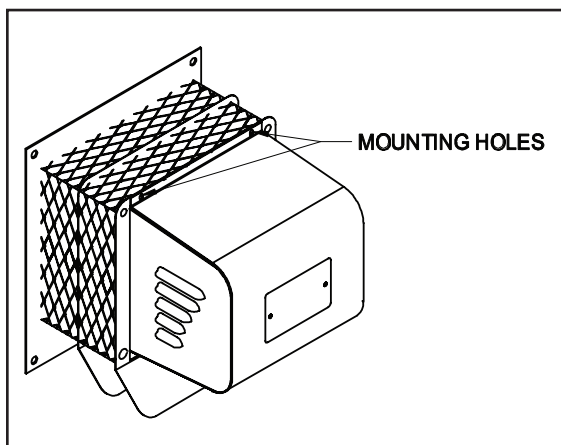

Figure 18

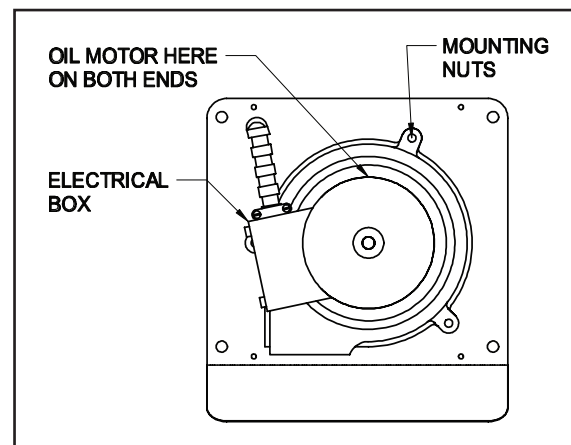

Figure 19

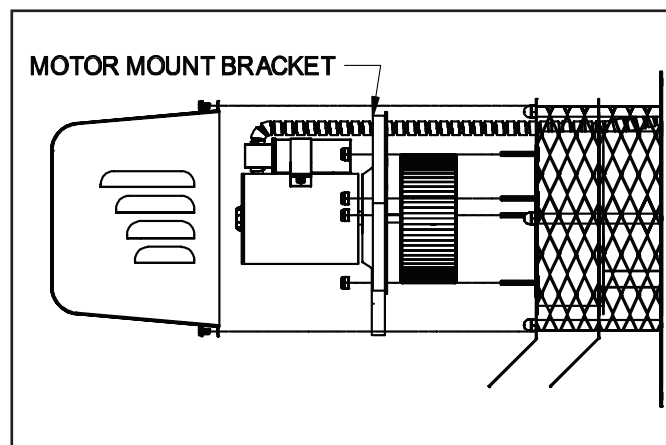

Figure 20

INITIAL BURNER AND VENTING SYSTEM OPERATIONAL INFORMATION

List the following for each operating appliance on the sidewall venting system, as a guide for tune-up or service information annually.

DATE:								
Heating Appliance BTU/HR Input								
Gas Valve Operation Pressure								
Vent System Draft Above Draft Hood								
CO ₂ Measurement								
CO Measurement								
Equipment Outlet Flue Gas Temperature								

LIMITED WARRANTY

Field Controls, LLC ("Company") warrants that its products shall be free from defects in material and workmanship under normal use for the limited period indicated, **from the date of manufacture, subject to the provisions 1-8 below.**

Eighteen (18) months

All Field Controls Products (except for those listed below as 5 years or 90 days).

Five (5) years

Field Controls Direct Vent Systems (FDVS), Field Oil Vent Kits (FOVP), and ComboVents (CV).

Field Controls warrants that the products listed below shall be free from defects in material and workmanship under normal use for the limited period indicated, **from the date of purchase by the consumer, subject to the provisions 1-8 below.**

Ninety (90) days

UV lamps/bulbs

Provisions:

1. During the limited warranty period, Company, or its authorized service representative, will repair or replace, at Company's option, without charge, a defective Product. Product that is repaired may be repaired with new or refurbished replacement parts. Product that is replaced may be replaced with a new or refurbished product of the same or similar design. Company will return repaired or replacement Product to customer in working condition. Labor charges are not covered as part of the limited warranty.
2. With regard to UV lamps/bulbs, customer shall be required to include a "valid proof of purchase" (sales receipt) identifying the Product purchased (Product model or accurate date code information) and the date the Product(s) was purchased.
3. Product whose warranty/quality stickers, Product serial number plates or electronic serial numbers have been removed, altered or rendered illegible shall not be covered under the limited warranty.
4. Defective Product must be returned to Company, postage prepaid.
5. IN NO EVENT SHALL COMPANY BE LIABLE FOR ANY INDIRECT, SPECIAL, INCIDENTAL, CONSEQUENTIAL, OR SIMILAR DAMAGES (INCLUDING, BUT NOT LIMITED TO, LOST PROFITS OR REVENUE, INABILITY TO USE PRODUCT, OR OTHER ASSOCIATED EQUIPMENT, THE COST OF SUBSTITUTE EQUIPMENT, AND CLAIMS BY THIRD PARTIES) RESULTING FROM THE USE OF PRODUCT. Some states do not allow the exclusion or limitation of incidental or consequential damages, so the above limitation or exclusion may not apply to you.
6. THIS WARRANTY AND REMEDIES ARE EXCLUSIVE AND IN LIEU OF ALL OTHER WARRANTIES, REMEDIES AND CONDITIONS, WHETHER ORAL, WRITTEN, EXPRESS, STATUTORY OR IMPLIED. TO THE EXTENT PERMITTED BY LAW, COMPANY DISCLAIMS ALL IMPLIED AND STATUTORY WARRANTIES, INCLUDING WARRANTIES OF MERCHANTABILITY AND FITNESS FOR A PARTICULAR PURPOSE.
7. Company makes no warranty of any kind in regard to other manufacturer's products distributed by Company. Company will pass on all warranties made by the manufacturer and where possible, will expedite the claim on behalf of the customer, but ultimately, responsibility for disposition of the warranty claim lies with the manufacturer.
8. Product that has been subjected to misuse, accident, shipping or other physical damage, improper installation or application, abnormal operation or handling, neglect, fire, water or other liquid intrusion are not covered by the warranty.



FIELD CONTROLS

Phone: 252.522.3031 • Fax: 252.522.0214
www.fieldcontrols.com