

Installation and Operation Manual

Electric Water Heater

THE WARRANTY ON THIS WATER HEATER IS IN EFFECT ONLY WHEN THE WATER HEATER IS INSTALLED AND OPERATED IN ACCORDANCE WITH LOCAL CODES AND THESE INSTRUCTIONS. THE MANUFACTURER OF THIS HEATER WILL NOT BE LIABLE FOR ANY DAMAGE RESULTING FROM FAILURE TO COMPLY WITH THESE INSTRUCTIONS. READ THESE INSTRUCTIONS THOROUGHLY BEFORE STARTING.

For your family's comfort, safety and convenience, it is recommended this water heater be installed and serviced by a plumbing professional.

CONGRATULATIONS!

You have purchased one of the finest water heaters on the market today!

This installation, operation and instruction manual will explain in detail the installation and maintenance of your new water heater. We strongly recommend that you contact a plumbing professional for the installation of this water heater.

We require that you carefully read this manual, as well as the enclosed warranty, and refer to it when questions arise. If you have any specific questions concerning your warranty, please consult the plumbing professional from whom your water heater was purchased. For your records we recommend that you write the model, serial number and installation date of your water heater in the maintenance section in the back of this manual.

This manual should be kept with the water heater.

Table of Contents

	Page
Warnings, Cautions and Information	3
General Information	5
Installation	6
Locating the Water Heater	6
Clearances	10
Technical Characteristics	10
Water Connections	10
Electrical Connections	15
General Operation	17
Thermostat Adjustment	19
Maintenance	20

Appliance Rating: IP23 wall hung models
IP44 upright models

MADE IN SERBIA

⚠ WARNING

This appliance is not intended for use by persons (including children) with reduced physical, sensory or mental capabilities, or lack of experience and knowledge, unless they have been given supervision or instruction concerning use of the appliance by a person responsible for their safety.

Children should be supervised to ensure that they do not play with the appliance.

⚠ WARNING

DURING ELECTRICAL INSTALLATION, INSTALL A DISCONNECT SWITCH AND/OR APPROPRIATELY SIZED BREAKER TO SEPARATE ALL POLES FROM THE POWER SUPPLY IN ACCORDANCE WITH LOCAL AND NATIONAL REGULATIONS. APPLIANCE IS TO BE INSTALLED ON A DEDICATED CIRCUIT.

⚠ WARNING

The combination temperature and pressure relief valve shall be marked with a maximum set pressure, not to exceed the maximum working pressure of the water heater. The combination temperature and pressure relief valve shall also have an hourly rated temperature steam BTU discharge capacity not less than the hourly input rating of the water heater.

Install the combination temperature and pressure relief valve into the opening provided and marked for this purpose on the water heater.

Maximum Inlet Water Pressure		Minimum Inlet Water Pressure
With PRV*	80 psi/0.55 MPa	N/A
Without PRV*	60 psi/0.41 MPa	N/A

*Pressure Reducing Valve

IMPORTANT

It is recommended to have at least 18 inches of clearance from the top, and 24 inches of clearance from the front. Clearance may be reduced, but service time and effort may be greatly increased.

IMPORTANT

This water heater is not equipped with a power indicator or thermometer. This water heater is intended to be installed in a concealed location or away from the location of use.

IMPORTANT

The unit is to be operated at the frequency shown on the rating plate. If the frequency is shown as 50/60Hz, the heater can be operated without any changes.

IMPORTANT

This appliance is intended to be permanently connected to the water main, and not by a hose-set.

IMPORTANT

- A discharge pipe connected to the pressure-relief device is to be installed in a continuously downward direction and in a frost-free environment.
- The water may drip from the discharge pipe of the pressure-relief device and this pipe must be left open to the atmosphere.
- The pressure-relief device is to be operated regularly to remove lime deposits and to verify that it is not blocked.

IMPORTANT

TO DRAIN THE WATER HEATER

Should it become necessary to completely drain the water heater, make sure you follow the steps below:

1. Disconnect the power supply to the water heater. Consult the plumbing professional or electric company in your area for service.
2. Close the cold-water supply shut-off valve.
3. Open the drain valve (if provided) on the water heater by inserting a standard flat head screwdriver into the slot and turning counterclockwise. The drain valve has threads on the end that will allow connection of a standard hose coupling. For those models not equipped with a drain valve, disconnect cold water inlet piping at a convenient connection location as close to an adequate drain as possible.
4. **CAUTION! THIS WATER MAY BE HOT.** Open a hot water faucet to allow air to enter the system.

IMPORTANT

Note: Per Section 507.2 Seismic Provisions of the 2021 Uniform Plumbing Code (UPC). Water heaters shall be anchored or strapped to resist horizontal displacement due to earthquake motion. Strapping shall be at points within the upper one-third and lower one-third of its vertical dimensions. At the lower point, a distance of not less than 4 inches shall be maintained from the controls with the strapping.

GENERAL INFORMATION

This water heater must be installed in accordance with local codes. In the absence of local codes, install this water heater in accordance with the N.E.C. Reference Book (latest edition).

The warranty for this water heater is in effect only when the water heater is installed, adjusted, and operated in accordance with these Installation and Operating Instructions. The manufacturer will not be held liable for damage resulting from alteration and/or failure to comply with these instructions.

This water heater has been designed and certified for the purpose of heating potable water. The installation and use of this water heater for any purpose other than the heating of potable water may cause damage to the water heater, create a hazardous condition and nullify the warranty.

⚠ CAUTION

Incorrect operation of this appliance may create a hazard to life and property and will nullify the warranty.

Do not use this appliance if any part has been submerged in water. The plumbing professional responsible for the installation of this water heater should be contacted to inspect the appliance and to replace any part of the control system, including thermostat, which has been submerged in water.

Make sure that the rating plate is referenced that the correct voltage is being supplied to the water heater.

⚠ DANGER

Do not store or use gasoline or other flammable, combustible, or corrosive vapors and liquids in the vicinity of this or any other appliance.

⚠ WARNING

This appliance is not intended for use by persons (including children) with reduced physical, sensory or mental capabilities, or lack of experience and knowledge, unless they have been given supervision or instruction concerning use of the appliance by a person responsible for their safety.

Children should be supervised to ensure that they do not play with the appliance.

A sacrificial anode is used to extend tank life. Removal of this anode, for any reason, will nullify the warranty. In areas where water is unusually active, an odor may occur at the hot water faucet due to a reaction between the sacrificial anode and impurities in the water. If this should happen, an aluminum anode may be

General Information continued-

purchased from the supplier and installed in the water heater. This will minimize the odor while protecting the tank. Additionally, the water heater should be flushed with appropriate dissolvers to eliminate any bacteria.

If the supply cord is damaged, it must be replaced by an approved cord or assembly available from the manufacturer or its service agent.

IMPORTANT

Before proceeding, please inspect the water heater and its components for possible damage. **DO NOT** install any damaged components. If damage is evident, please contact the supplier where the water heater was purchased, or the manufacturer listed on the rating plate for replacement parts.

INSTALLATION

Locating the Water Heater

⚠ WARNING

Water heaters are heat producing appliances. To avoid damage or injury, there shall be no materials stored against the water heater and proper care shall be taken to avoid unnecessary contact (especially by children) with the water heater. **UNDER NO CIRCUMSTANCES SHALL FLAMMABLE MATERIALS, SUCH AS GASOLINE OR PAINT THINNER BE USED OR STORED IN THE VICINITY OF THIS WATER HEATER OR ANY LOCATION FROM WHICH FUMES COULD REACH THE WATER HEATER.**

This water heater shall NOT be installed in any location where gasoline or flammable vapors are likely to be present, unless the installation is such to eliminate the probable ignition of gasoline or flammable vapors.

The location of this water heater is of the utmost importance. Before installing the water heater, select a location that is accessible to water supply lines and the power supply. It is recommended that the water heater be located near the center of greatest hot water usage to prevent heat loss through the pipes.

DO NOT locate the water heater where water lines could be subjected to freezing temperatures. Locate the water heater so that access panels and drain valves are accessible.

This water heater MUST be installed indoors. Failure to install this water heater indoors and protected from wind and weather will void the warranty. For vertical installation, the water heater must be installed in a vertical position with the water fittings pointing upward. The water heater must be positioned on the appropriate surface. For horizontal installation, the water heater must be installed horizontally, on the appropriate surface, with water fittings pointing downward.

NOTE: Take into consideration the filled weight of the water heater.

Installation continued-

This water heater must be located in an area where leakage of the tank or water line connections and the combination temperature and pressure relief valve will not result in damage to the area adjacent to the water heater or to lower floors of the structure.

⚠ WARNING

In a closed, pressurized system of installation, it is required to install a temperature and pressure relief valve with a rated pressure equivalent to the working pressure of the heater.

IMPORTANT

If required by local codes, all anchoring and strapping points shall be within the upper one-third and lower one-third of its vertical dimensions. At the lower point, a distance of not less than 4 inches shall be maintained from the controls with strapping. Please refer to local codes having jurisdiction if there is any additional requirements regarding fixing and supporting the appliance.

- A discharge pipe connected to the pressure-relief device is to be installed in a continuously downward direction and in a frost-free environment.
- The water may drip from the discharge pipe of the pressure-relief device and this pipe must be left open to the atmosphere.
- The pressure-relief device is to be operated regularly to remove lime deposits and to verify that it is not blocked.

DURING ELECTRICAL INSTALLATION, INSTALL A DISCONNECT SWITCH AND/OR APPROPRIATELY SIZED BREAKER TO SEPARATE ALL POLES FROM THE POWER SUPPLY IN ACCORDANCE WITH LOCAL AND NATIONAL REGULATIONS. APPLIANCE IS TO BE INSTALLED ON A DEDICATED CIRCUIT.

The method of fixing is not to depend on the use of adhesives since they are not considered to be a reliable fixing means.

For wall hung models (BWXXWH), the unit must be fitted to the wall using appropriate wall screws with a minimum length and diameter shown in the table below. A wall with a poor load-bearing capacity must be properly reinforced where the heater will be installed.

Screw length (mm)	100
Screw diameter (mm)	10

Installation continued-

TO DRAIN THE WATER HEATER

Should it become necessary to completely drain the water heater, make sure you follow the steps below:

1. Disconnect the power supply to the water heater. Consult the plumbing professional or electric company in your area for service.
2. Close the cold-water supply shut-off valve.
3. Open the drain valve (if provided) on the water heater by inserting a standard flat head screwdriver into the slot and turning counterclockwise. The drain valve has threads on the end that will allow connection of a standard hose coupling. For those models not equipped with a drain valve, disconnect cold water inlet piping at a convenient connection location as close to an adequate drain as possible.

CAUTION! THIS WATER MAY BE HOT.

4. Open a hot water faucet to allow air to enter the system.

To refill the water heater, refer to "TO FILL THE WATER HEATER."

Water heater corrosion and component failure can be caused by the heating and breakdown of airborne chemical vapors. Examples of some typical compounds that are potentially corrosive are: spray can propellants, cleaning solvents, refrigerator and air conditioning refrigerants, swimming pool chemicals, calcium or sodium chloride, waxes, and process chemicals. These materials are corrosive at very low concentration levels with little or no odor to reveal their presence.

NOTE: DAMAGE TO THE WATER HEATER CAUSED BY EXPOSURE TO CORROSIVE VAPORS IS NOT COVERED BY THE WARRANTY. DO NOT OPERATE THE WATER HEATER IF EXPOSURE HAS OR WILL OCCUR. DO NOT STORE ANY POTENTIALLY CORROSIVE COMPOUNDS IN THE VICINITY OF THE WATER HEATER.

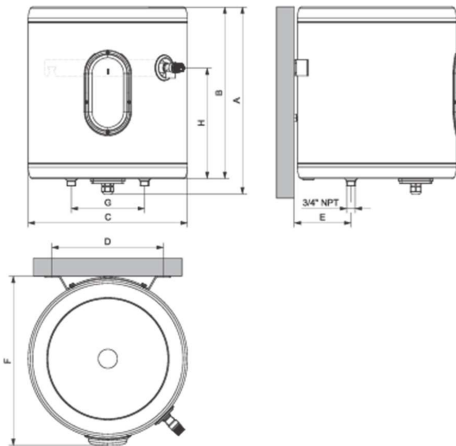

Fig. 1

**Dimensions for
Wall Hung Models**

	A (mm)	B (mm)	C (mm)	D (mm)	E (mm)	F (mm)	G (mm)	H (mm)
BW45WH	587	539	500	350	178	532	230	348
BW75WH	712	664	500	350	178	532	230	473
BW115WH	1003	955	500	350	178	532	230	764

Installation continued-

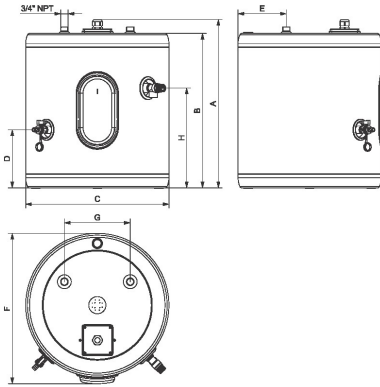

Fig. 2

Dimensions for Utility Models

	A (mm)	B (mm)	C (mm)	D (mm)	E (mm)	F (mm)	G (mm)	H (mm)
BW45U	568	538	500	202	168	525	230	347
BW75U	743	713	500	202	168	525	230	522
BW115U	984	954	500	202	168	525	230	763

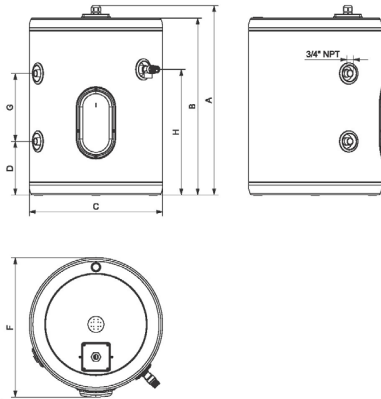

Fig. 3

Dimensions for Lowboy Models

	A (mm)	B (mm)	C (mm)	D (mm)	E (mm)	F (mm)	G (mm)	H (mm)
BW75S	712	665	500	202	NA	525	255	473

Clearances

It is recommended to have at least 18 inches of clearance from the top, and 24 inches of clearance from the front. Clearance may be reduced, but service time and effort may be greatly increased.

Technical Characteristics

Type	BW45 (L,U,WH)	BW75 (L,U,WH)	BW115 (R,U,WH)
Test Pressure	2 MPa / 20 bar / 290 psi		
Working Pressure	1 MPa / 10 bar / 145 psi		
Net Weight (empty)	23 kg (51 lb)	28 kg (62 lb)	36 kg (80 lb)
Water Connections	¾" NPT		
Temperature Range	32 to 66 °C 90 to 150 °F		

The unit is to be operated at the frequency shown on the rating plate. If the frequency is shown as 50/60Hz, the heater can be operated without any changes.

Water Connections

NOTE: BEFORE PROCEEDING WITH THE INSTALLATION, CLOSE THE MAIN WATER SUPPLY VALVE.

After shutting off the main water supply valve, open a faucet to relieve the water line pressure. This will prevent any water from leaking out of the pipes while making the water connections to the water heater. After the pressure has been relieved, close the faucet. The cold-water inlet and hot water outlet are identified on the water heater. The fittings at the cold-water inlet and hot water outlet have tapered male threads shown in the above technical characteristics table. Make the proper plumbing connections between the water heater and the plumbing system in the house. This appliance is intended to be permanently connected to the water main, and not by a hose-set. Install a shut-off valve in the cold-water supply line. Inlet and outlet pipes of the water heater are color-coded. The supply of cold water is marked with a blue ring. The outlet of warm water is marked with a red ring.

Water Connections continued-

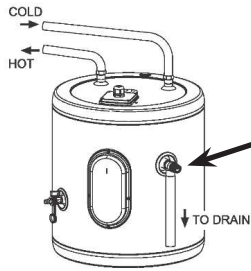

Fig. 4

T&P Location

CAUTION

If sweat fittings are to be used, **DO NOT** apply heat to the nipples on the water heater. Sweat the tubing to the adapter before fitting the adapter to the water connections. It is imperative that heat is not applied to the nipples containing a plastic liner.

IMPORTANT

FAILURE TO INSTALL AND MAINTAIN A NEW, APPROPRIATELY SIZED TEMPERATURE-PRESSURE RELIEF VALVE OR PRESSURE SAFETY VALVE WILL RELEASE THE MANUFACTURER FROM ANY CLAIM WHICH MIGHT RESULT FROM EXCESSIVE TEMPERATURE AND PRESSURES.

If this water heater is installed in a closed water supply system, such as the one having a back-flow preventer in the cold-water supply, provisions shall be made to control thermal expansion.

CAUTION

DO NOT OPERATE THIS WATER HEATER IN A CLOSED SYSTEM WITHOUT PROVISIONS FOR CONTROLLING THERMAL EXPANSION.

Your water supplier or local plumbing inspector should be contacted on how to control this situation. After installation of the water lines, open the main water supply valve and fill the water heater. While the water heater is filling, open several hot water faucets to allow air to escape from the water system. When a steady stream of water flows through the faucets, close them and check all water connections for possible leaks.

NEVER OPERATE THE WATER HEATER WITHOUT FIRST BEING CERTAIN IT IS FILLED WITH WATER.

Water Connections continued-

Wall Hung Models

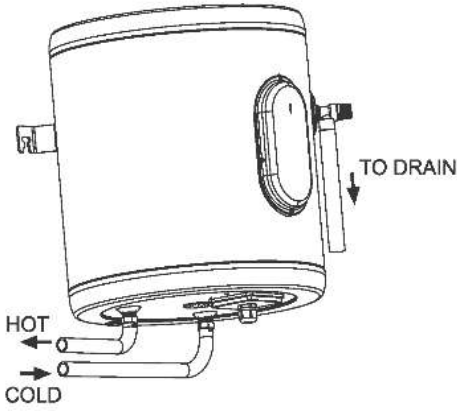
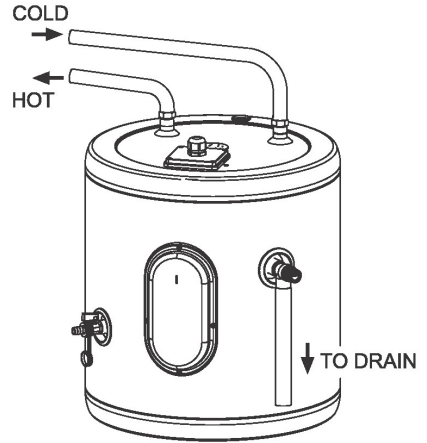
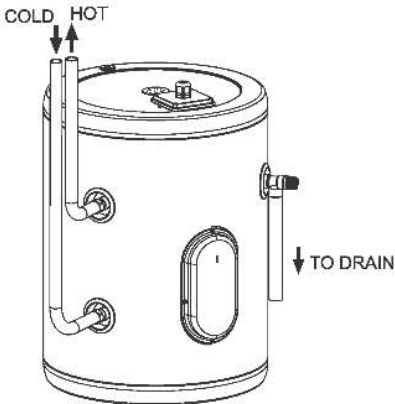

Fig. 5

Water Connections



Utility Models



Lowboy Models

⚠ WARNING

For protection against excessive temperatures and pressure, install temperature and pressure protective equipment required by local codes, but not less than a combination temperature and pressure relief valve certified by a nationally recognized testing laboratory that maintains periodic inspection of production of listed equipment or materials, as meeting the Requirements for Relief Valves and Automatic Gas Shutoff Devices for Hot Water Supply Systems, ANSI Z21.22, and the Standard CSA 4.4 Temperature, Pressure, Temperature and Pressure Relief Valves and Vacuum Relief Valves. The combination temperature and pressure relief valve shall be marked with a maximum set pressure, not to exceed the maximum working pressure of the water heater. The combination temperature and pressure relief valve shall also have an hourly rated temperature steam BTU discharge capacity not less than the hourly input rating of the water heater.

Install the combination temperature and pressure relief valve into the opening provided and marked for this purpose on the water heater

Note: Some models may already be equipped or supplied with a combination temperature and pressure relief valve. Verify that the combination temperature and pressure relief valve complies with local codes. If the combination temperature and pressure relief valve does not comply with local codes, replace it with one that does. Follow the installation instructions above on this page.

Install a discharge line so that water discharged from the combination temperature and pressure relief valve will exit within six (6) inches (*15.3 cm*) above, or any distance below the structural floor and cannot contact any live electrical part. The discharge line is to be installed to allow for complete drainage of both the temperature and pressure relief valve and the discharge line. The discharge opening must not be subjected to blockage or freezing. **DO NOT** thread, plug or cap the discharge line. It is recommended that a minimum of four (4) inches (*10.2 cm*) be provided on the side of the water heater for servicing and maintenance of the combination temperature and pressure relief valve.

Do not place a valve between the combination temperature and pressure relief valve and the tank.

Water Connections continued-

⚠ CAUTION

INCREASING THE THERMOSTAT SETTING ABOVE THE PRESET TEMPERATURE MAY CAUSE SEVERE BURNS AND CONSUME EXCESSIVE ENERGY. HOTTER WATER INCREASES THE RISK OF SCALD INJURY.

This water heater can deliver scalding temperature water at any faucet in the system. Be careful whenever using hot water to avoid scalding injury. Certain appliances, such as dishwashers and automatic clothes washers, may require increased temperature water. By setting the thermostat on this water heater to obtain increased temperature water required by these appliances, you may create the potential for scald injury. To protect against injury, you should install an ASSE approved mixing valve in the water system. This valve will reduce the point of discharge temperature by mixing cold and hot water in branch supply lines. Such valves are available from the manufacturer of this water heater or a local plumbing supplier. Please consult with a plumbing professional.

	Water temperature over 125°F (52°C) can cause severe burns instantly or death from scalds.
	Children, disabled, and elderly are at highest risk of being scalded.
	Review this instruction manual before setting temperature at water heater.
	Feel water before bathing or showering.
	Temperature limiting valves are available, contact local plumbing supplier.

Approximate Time/Temperature Relationships in Scalds

120°F (49°C)	More than 5 minutes
125°F (52°C)	1 1/2 to 2 minutes
130°F (54°C)	About 30 seconds
135°F (57°C)	About 10 seconds
140°F (60°C)	Less than 5 seconds
145°F (63°C)	Less than 3 seconds
150°F (66°C)	About 1 1/2 seconds
155°F (68°C)	About 1 second

Electrical Connections

Before any electrical connections are made, be sure that the water heater is full of water and that the manual shut-off valve in the cold-water supply line is open. Check the rating plate and wiring diagram before proceeding. This electric water heater was built and wired in accordance with the IEC testing approvals requirements. The temperature limiting device is of the manual reset, trip-free type and has been factory installed to interrupt all ungrounded power supply conductors in the event of thermostat failure. Thermostats are factory set and wired in accordance with the wiring diagram fastened to the inside of the top access panel. The plumbing supplier in your area ordered this heater wired at the factory to comply with existing area codes, but local utility codes may require or allow other circuitry. Consult your local power company to determine the correct electrical hook-up in order to meet local utility and building codes and in order to obtain the most economical rates. Also check to find out if you are required to obtain a permit before starting the installation. The maximum wattage and rated voltage are shown on the water heater data plate. The water heater must be well grounded. Must have some means of disconnect that follow local utility and building codes. An opening for 3/4-inch electrical fitting is provided for field wiring connections. Check the rating plate and diagram before proceeding. Protection should be adequate to the electrical demand of the heater.

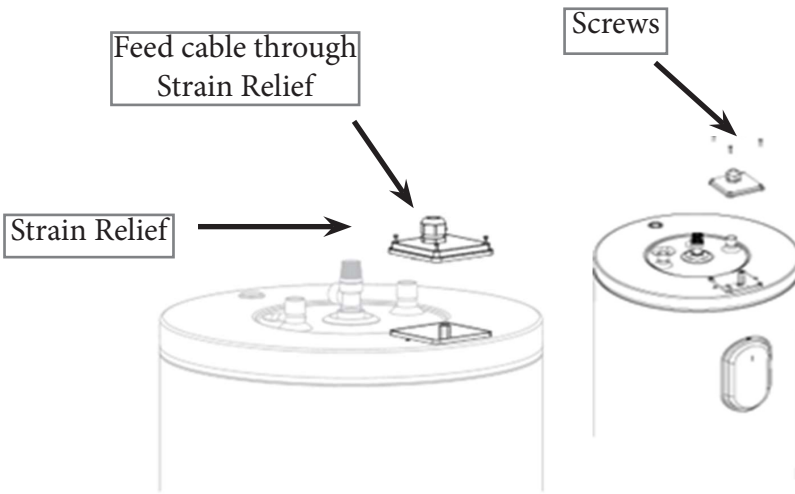

Fig. 6

Junction Box

1. Remove the lid of the junction box by unscrewing the 4 screws as shown in Figure 6.
2. Loosen strain relief and place electrical cable through the strain as shown in Figure 6.
3. Attach wiring to the terminal block per Figures 7 and 8 depending on the phase of your unit.
4. Re-attach the lid with the 4 screws to close the junction box.
5. Tighten the strain relief until hand tight.

Electrical Connections continued-

⚠ CAUTION

This unit is to be used with fixed wire cabling ONLY.

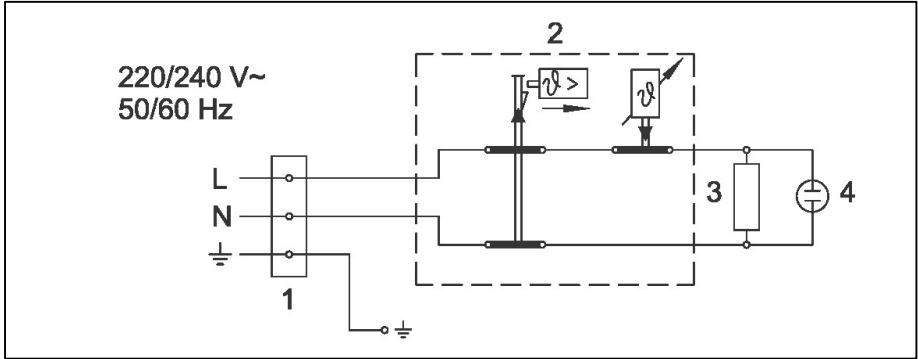

Fig. 7 1 Phase (220V-240V)

Legend

1	Junction Box
2	Thermostat with resettable hi-limit switch/energy cut out
L	Live Conductor
N	Neutral Conductor
⊕	Ground Conductor

⚠ WARNING

WATER HEATER EQUIPPED FOR LIMITED RANGE OF VOLTAGE!

This water heater is equipped for voltage 220/240 VAC (208/240 in select markets). Check rating plate of the device for the correct voltage. DO NOT use this water heater with any voltage other than that shown on the rating plate. Failure to use the correct voltage may cause serious problems for the safety of persons and the device.

SAFETY SHUT-OFF

Water heaters have a thermostat with resettable hi-limit switch/energy cut out (i.e. bipolar safety thermostat) that works in case of abnormal heating of water. The operation of the safety thermostat causes automatic opening of the circuit of the electrical heating element, whose resetting is manual and must be done after the elimination of the cause of the anomaly. If this anomaly occurs, call an authorized service center.

GENERAL INFORMATION

IMPORTANT

Before closing the switch to allow electric current to flow to the water heater, make certain that the water heater is full of water and that the cold-water inlet valve is open. Complete failure of the heating element(s) will result if they are not always immersed in water. Failure of the element(s) due to dry firing is not covered by warranty.

When the switch is closed, the operation of this electric water heater is automatic.

⚠ CAUTION

Scalding may occur within five (5) seconds at a temperature setting of 60°C (140°F).

Care must be taken whenever using hot water to avoid scalding injury. Certain appliances require high temperature hot water (such as dishwashers and automatic clothes washers).

TO FILL THE WATER HEATER

1. Close the water heater drain valve (if provided) by inserting a standard flat head screwdriver into the slot and turning clockwise.
2. Open the cold-water supply shut-off valve.
3. Open several hot water faucets to allow air to escape from the system.
4. When a steady stream of water flows from the faucets, the water heater is filled. Close the faucets and check for water leaks at the water heater drain valve, combination temperature and pressure relief valve and the hot and cold-water connections.

TO DRAIN THE WATER HEATER

Should it become necessary to completely drain the water heater, make sure you follow the steps below:

1. Disconnect the power supply to the water heater. Consult the plumbing professional or electric company in your area for service.
2. Close the cold-water supply shut-off valve.
3. Open the drain valve (if provided) on the water heater by inserting a standard flat head screwdriver into the slot and turning counterclockwise. The drain valve has threads on the end that will allow connection of a standard hose coupling. For those models not equipped with a drain valve, disconnect cold water inlet piping at a convenient connection location as close to an adequate drain as possible.
CAUTION! THIS WATER MAY BE HOT.
4. Open a hot water faucet to allow air to enter the system.

To refill the water heater, refer to "TO FILL THE WATER HEATER."

General Information continued-

Thermostat Adjustment

Setting the Water Temperature

1. Unless otherwise noted, all models sold to Saudi Arabia are preset to 60°C, all other models are set to 52°C.
2. KSA models are set 60°C. (for non-KSA models, ensure dial is set to a safe temperature range).
3. Authorized person can change thermostat setting by removing protective cover, turning the thermostat adjustment screw on the side of the electric water heater. Align markings on thermostat and adjustment screw to desired water temperature.

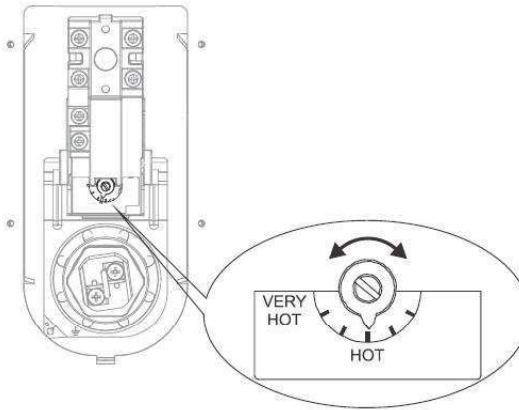

Fig. 8

Setting the Water Temperature

▲ DANGER

Hotter water increases the risk of scald injury. Scalding may occur within five (5) seconds at a temperature setting of 140°F (60°C). To protect against hot water injury, install an ASSE approved mixing valve in the water system. This valve will reduce point of discharge water temperatures by mixing cold and hot water in branch water lines. A licensed plumbing professional or local plumbing authority should be consulted.

Note: This water heater is equipped with an energy cut out device to prevent overheating. Should overheating occur, turn off the electrical supply to the water heater and contact a qualified service technician.

Thermostat Adjustment continued-

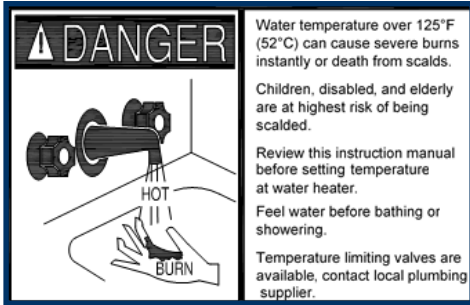

Approximate Time/Temperature Relationships in Scalds	
120°F (49°C)	More than 5 minutes
125°F (52°C)	1 1/2 to 2 minutes
130°F (54°C)	About 30 seconds
135°F (57°C)	About 10 seconds
140°F (60°C)	Less than 5 seconds
145°F (63°C)	Less than 3 seconds
150°F (66°C)	About 1 1/2 seconds
155°F (68°C)	About 1 second

LIGHT INDICATOR

The operation of the heating element is indicated by the light indicator that stays on until the temperature in the tank has reached the set level or until the heater has been deliberately switched off.

ANTIFREEZING PROTECTION

When the water heater is not in use for longer periods of time, it should be protected from freezing by setting the temperature to the minimum possible position. Do not disconnect the power. Should you choose to disconnect the power, the water heater should be thoroughly drained before the onset of freezing conditions (see Draining of the Water Heater).

CLEANING

It is advised to clean the outer cover with a soft cloth and a mild solution of washing liquid. The use of abrasive or solvent cleaning fluids should be avoided.

MAINTENANCE

IMPORTANT

The water heater should be inspected at a minimum of annually by a qualified service technician for damaged components. **DO NOT** operate this water heater if any part is found damaged.

Shut off the electric power whenever the water supply to the water heater is off. Shut off the electric power and water supply, drain the heater completely to prevent freezing whenever the building is left unoccupied during the cold weather months. To ensure efficient operation and long tank life, drain the water heater at least once a month through the drain valve until the water runs clear. Failure to do this may result in noisy operation and lime and sediment buildup in the bottom of the tank. Check the temperature-pressure relief valve or pressure safety valve, to ensure that the valve has not become encrusted with lime. Lift the lever at the top, or twist the top, (depending on the style of valve you have) several times until the valve seats properly without leaking and operates freely.

⚠ WARNING

When lifting lever of temperature-pressure relief valve, or twisting to open, hot water will be released under pressure. Be certain that any released water does not result in bodily injury or property damage. The magnesium anode rod should be inspected periodically and replaced when necessary to prolong tank life.

The following maintenance should be performed by a qualified service technician at the minimum periodic intervals suggested below. In some installations, the maintenance interval may be more frequent depending on the amount of use and the operating conditions of the water heater. Regular inspection and maintenance of the water heater will help to ensure safe and reliable operation.

1. Annually, check the operation of the thermostat(s).
2. Bi-annually, check the seal around the heating elements for leaks. If there is any sign of leaking, disconnect the power supply to the water heater and contact the plumbing professional that installed this water heater or a qualified service technician.
3. If the combination temperature and pressure relief valve on the appliance discharges periodically, this may be due to thermal expansion in a closed water supply system. Contact the water supplier or local plumbing inspector on how to correct this situation. Do not plug the combination temperature and pressure relief valve outlet for any reason.
4. Monthly, drain off a gallon of water from the water heater to remove silt and sediment.
5. The anode rod should be inspected periodically (every 2 years) and replaced when necessary to prolong tank life. Water conditions in your area will influence the time interval for inspection and replacement of the anode rod. Contact the plumbing professional who installed the water heater, or the manufacturer listed on the rating plate for anode replacement information. The use of a water softener may increase the speed of anode consumption. More frequent inspection of the anode is needed when using softened (or phosphate treated) water.

Maintenance continued-

WARNING

THIS WATER MAY BE HOT.

CAUTION

FOR YOUR SAFETY, **DO NOT** ATTEMPT TO REPAIR THERMOSTAT(S), HEATING ELEMENTS, OR ELECTRICAL WIRING. REFER SUCH REPAIRS TO A QUALIFIED SERVICE TECHNICIAN.

Draining the Water Heater

1. Unplug the water heater.
2. Open the hot tap to let hot water out. Continue flowing until cold water is running freely from faucet.
3. Turn off cold water supply.
4. Close the hot water faucet.
5. Connect suitable hose to draining valve to prevent uncontrolled spilling.
6. Open drain valve to drain the water.

Contact your local plumbing supplier or plumbing professional for replacement parts or contact the company at the address displayed on the rating plate of the water heater.

For faster and better service, please provide the part name, model, and serial number(s) of the water heater(s) when ordering parts.

READ THE WARRANTY FOR A FULL EXPLANATION OF THE LENGTH OF TIME THAT PARTS AND THE WATER HEATER ARE WARRANTED.

Complete the following information and retain for future reference:

Model No: _____

Serial No: _____

Service Phone

Days: _____ **Nights:** _____

Address: _____

Supplier: _____

Supplier Phone No: _____

General Contact / Sales Information: international@bradfordwhite.com

Technical Support: export.techsupport@bradfordwhite.com

Warranty: export.warranty@bradfordwhite.com

Notes



Notes

A large grid of small dots arranged in approximately 25 columns and 40 rows, intended for taking notes.