

ULTRA HIGH EFFICIENCY COMMERCIAL GAS WATER HEATER



INSTALLATION/OPERATION MANUAL **WITH TROUBLESHOOTING GUIDE**



▲ WARNING: If the information in these instructions is not followed exactly, a fire or explosion may result causing property damage, personal injury or death

Do not store or use gasoline or other flammable vapors and liquids in the vicinity of this or any other appliance

WHAT TO DO IF YOU SMELL GAS

- Do not try to light any appliance.
- Do not touch any electrical switch; do not use any phone in your building.
- Immediately call your gas supplier from a neighbor's phone. Follow the gas supplier's instructions.
- If you cannot reach your gas supplier, call the fire department.

Installation and service must be performed by a qualified installer, service agency or gas supplier.



PLACE THESE INSTRUCTIONS ADJACENT TO HEATER AND NOTIFY OWNER TO KEEP FOR FUTURE REFERENCE

SECTION I: IMPORTANT INFORMATION

READ CAREFULLY

This water heater must be installed in accordance with national and/or local codes.

The following terms are used throughout this manual to bring attention to the presence of hazards at various risk levels, or to important information concerning product life.

DANGER

Indicates an imminently hazardous situation, which if not avoided, will result in death, serious injury or substantial property damage.

CAUTION

Indicates potentially hazardous situation, which if not avoided, may result in moderate or minor injury or property damage.

WARNING

Indicates a potentially hazardous situation, which if not avoided, could result in death, serious injury or substantial property damage.

NOTICE

Indicates special instructions on installation, operation or maintenance, which are important but not related to personal injury hazards.

NOTICE

This water heater has a limited warranty. The warranty for this water heater is valid only if the water heater has been installed, maintained and operated in accordance with these instructions.

TABLE OF CONTENTS

I	IMPORTANT INFORMATION.....	2	VIII	ELECTRICAL CONNECTIONS.....	30
II	SPECIFICATIONS.....	5	IX	COMMISSIONING.....	32
III	GENERAL INFORMATION.....	6	X	OPERATING INSTRUCTIONS.....	33
IV	INSTALLATION INSTRUCTIONS.....	8	XI	MAINTENANCE.....	40
V	WATER CONNECTIONS.....	13	XII	TROUBLE SHOOTING GUIDE.....	45
VI	VENTING.....	15	XIII	PARTS LIST.....	64
VII	GAS CONNECTIONS.....	29		NOTES.....	67

DANGER

DO NOT store or use gasoline or other flammable, combustible, or corrosive vapors and/or liquids in the vicinity of this or any other appliance.

DO NOT install any damaged venting system components. If damage is evident then please contact the supplier where the water heater was purchased or the manufacturer listed on the rating plate for replacement parts.

Use only vent terminals provided or factory authorized terminals for venting this water heater.

This water heater is equipped with an adjustable thermostat to control water temperature. Hot water temperatures required for automatic dishwasher and laundry use can cause scald burns resulting in serious personal injury and/or death. The temperature at which injury occurs varies with the person's age and the time of exposure. The slower response time of disabled persons increases the hazards to them. NEVER allow small children to use a hot water tap, or to draw their own bath water. NEVER leave a child or disabled person unattended in a bathtub or shower.

Failure to properly install the vent and air intake (if applicable) system could result in property damage, personal injury, or death

WARNING

Improper installation, adjustments, alteration, service or maintenance can cause property damage, personal injury or loss of life. Failure to follow all instructions in the proper order can cause personal injury or death. Read and understand all instructions, including all those provided with the appliance before installing, starting-up, operating, maintaining or servicing this appliance. Keep this manual and literature in legible condition with this water heater for reference by owner and service technician.

This water heater requires regular maintenance and service to operate safely. Follow the instructions contained in this manual.

Only a qualified, skilled and knowledgeable installer or service provider must perform installation, maintenance, and service.

Installation is not complete unless a temperature and pressure relief valve is installed into the proper location at the top of this water heater.

It is the responsibility of the installing contractor to see that all controls are correctly installed and are properly operating when the installation is complete.

This water heater is suitable for installation on combustible flooring. Do not install water heater on carpeting.

DO NOT operate this water heater without first being certain it is filled with water.

DO NOT tamper with or alter the water heater and/or controls.

DO NOT operate water heater with jumpered or absent controls or safety devices.

DO NOT operate water heater if any external part has been under water. Immediately call a qualified service agency to inspect the appliance and to replace any part of the control system including gas controls, which has been under water.

DO NOT attempt to use this water heater with any gas other than the type listed on the rating plate. Do not attempt to convert this water heater for use with a gas other than the type for which it is equipped. Failure to use the proper gas can create an unsafe condition resulting in property damage, bodily injury, or death. Consult your local gas supplier or gas company if there are any questions.

DO NOT operate this water heater if the input rate exceeds the rate shown on the water heater rating plate.

This water heater contains very hot water under high pressure. Do not unscrew any pipe fittings nor attempt to disconnect any components of this water heater without positively assuring the water is cool and is not under pressure. Always wear protective clothing and equipment when installing, starting up or servicing this water heater to prevent scald injuries. Do not rely on the temperature gauges to determine the temperature. Do not touch any components unless they are cool.

This water heater must be properly vented and connected to an approved vent system in good condition. DO NOT operate water heater with the absence of an approved vent system. A clean and unobstructed vent system is necessary to allow noxious fumes that could cause injury or loss of life to vent safely and will contribute toward maintaining the water heater's efficiency.

WARNING

This water heater needs air for safe operation and must be installed so there are provisions for adequate combustion and ventilation air. Insufficient air supply will cause a recirculation of combustion products resulting in contamination that may be hazardous to life. This will result in carboning or sooting of the combustion chamber, burners, and flue tubes and creates a risk of asphyxiation.

This water heater requires its own separate venting system. DO NOT connect the exhaust vent into an existing vent pipe or chimney.

Flammable items, pressurized containers or any other potential fire hazardous articles must never be placed on or adjacent to the water heater. Open containers of flammable material should not be stored or used in the same room with this water heater.

Hydrogen gas can be produced in an operating water heater that has not had water drawn from the tank for a long period of time (generally two weeks or more). Hydrogen gas is extremely flammable. To prevent the possibility of injury under these conditions, we recommend the hot water faucet to be open for several minutes at the kitchen sink before you use any electrical appliance, which is connect to the hot water system. If hydrogen is present, there will be unusual sounds such as air escaping through the pipes as hot water begins to flow. Do not smoke or have open flame near the faucet at the time it is open.

WARNING

Liquefied petroleum gases/propane gas is heavier than air and will remain at floor level if there is a leak. Basements, crawl spaces, closets and areas below ground level will serve as pockets for accumulation of leaking gas. Before lighting, smell all around the appliance area for gas. Be sure to smell next to the floor.

IF YOU SMELL GAS:

- DO NOT try to light any appliance.
- DO NOT touch any electric switch; do not use any telephone in your building.
- Immediately call your gas supplier from a telephone in another building. Follow the gas supplier's instructions.
- If you cannot reach your gas supplier, call the fire department.

DO NOT OPERATE THE APPLIANCE UNTIL THE LEAKAGE IS CORRECTED!

WARNING

Prior to connecting the gas supply line to a gas fired water heater, ensure that the gas supply line does not have moisture/water or dirt/scale inside the gas line. Commonly this check is done at the lowest point in the gas distribution system prior to gas burning appliances.

Do not use this appliance if any external part to the tank has been submerged in water. You should contact a qualified service technician to inspect the appliance and to replace any part of the control system including the combination gas control which has been submerged in water. See the Gas Connections section of this manual before servicing or replacing a water heater that has had any external part to the tank submerged in water.

SECTION II: SPECIFICATIONS

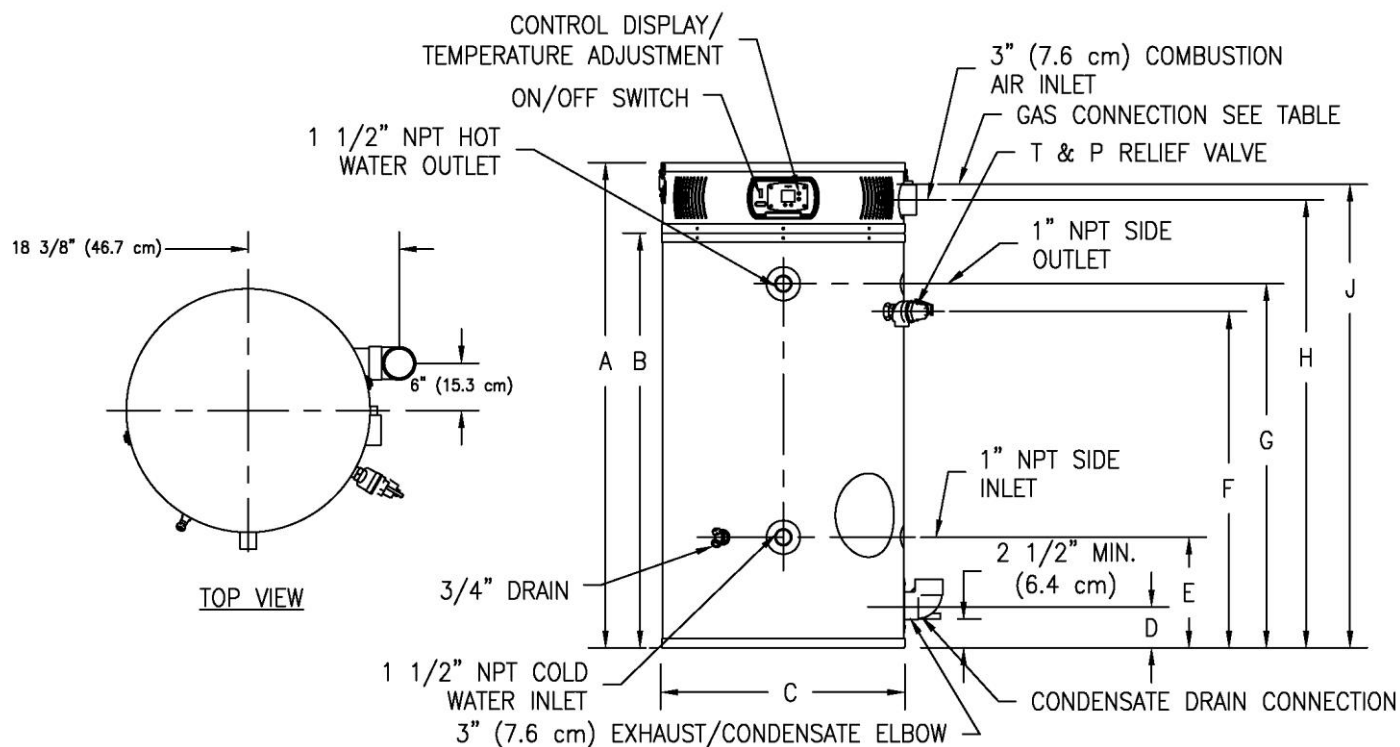

Figure 1. Dimensional Layout

Model No.	Input Rate BTU/h	Storage Capacity U.S. Gallons	DIMENSIONS (INCHES)													Shipping Wt. (LBS)
			A Height	B Floor to Top of Heater	C Jacket Dia.	D Floor to Vent Outlet	E Floor to Inlet Water Conn.	F Floor to T&P Valve Conn.	G Floor to Outlet Water Conn.	H Floor to Air Intake	J Floor to Gas Conn.	Front Water Conn. Dia.	Space Heating Conn. Dia.	Gas Conn. Dia.	Relief Valve Open	
60T125	125,000	60	57	48 7/16	28 1/4	5	12 7/8	40	42 1/4	51 5/8	53 1/4	1 1/2	1	3/4	3/4	570
60T150	150,000	60	57	48 7/16	28 1/4	5	12 7/8	40	42 1/4	51 5/8	53 1/4	1 1/2	1	3/4	3/4	570
60T199	199,999	60	57	48 7/16	28 1/4	5	12 7/8	40	42 1/4	51 5/8	53 1/4	1 1/2	1	3/4	3/4	570
100T150	150,000	100	77 5/8	69 7/16	28 1/4	5	12 7/8	60	62 1/4	73 1/8	74 1/4	1 1/2	1	3/4	3/4	900
100T199	199,999	100	77 5/8	69 7/16	28 1/4	5	12 7/8	60	62 1/4	73 1/8	74 1/4	1 1/2	1	3/4	3/4	900
100T250	250,000	100	77 5/8	69 7/16	28 1/4	5	12 7/8	60	62 1/4	73 1/8	74 1/4	1 1/2	1	3/4	1	900
100T300	300,000	100	77 5/8	69 7/16	28 1/4	5	12 7/8	60	62 1/4	73 1/8	74 1/4	1 1/2	1	3/4	1	900

Model No.	Input Rate KW	Storage Capacity Liter	DIMENSIONS (MILLIMETERS)													Shipping Wt. (KG)
			A Height	B Floor to Top of Heater	C Dia.	D Floor to Vent Outlet	E Floor to Inlet Water Conn.	F Floor to T&P Valve Conn.	G Floor to Outlet Water Conn.	H Floor to Air Intake	J Floor to Gas Conn.	Front Water Conn. Dia.	Space Heating Conn. Dia.	Gas Conn. Dia.	Relief Valve Open.	
60T125	36.6	227	1448	1231	718	127	327	1016	1073	1334	1353	38	25	19	19	259
60T150	43.9	227	1448	1231	718	127	327	1016	1073	1334	1353	38	25	19	19	259
60T199	58.6	227	1448	1231	718	127	327	1016	1073	1334	1353	38	25	19	19	259
100T150	43.9	379	1972	1764	718	127	327	1524	1581	1857	1886	38	25	19	19	408
100T199	58.6	379	1972	1764	718	127	327	1524	1581	1857	1886	38	25	19	19	408
100T250	73.2	379	1972	1764	718	127	327	1524	1581	1857	1886	38	25	19	25	408
100T300	87.9	379	1972	1764	718	127	327	1524	1581	1857	1886	38	25	19	25	408

Table 1. Specifications

SECTION III: GENERAL INFORMATION

FEATURES

This water heater contains the following features:

MAIN POWER ON/OFF SWITCH

The front panel of this water heater has a lighted ON/OFF switch, which is illuminated when the main power is turned on to indicate power to the water heater.

COMBUSTION SYSTEM

This water heater is equipped with a self-compensating negative pressure pre-mix combustion system. As the blower operates, air is drawn in through the air intake and into a venturi, which pulls gas from the gas valve. The gas and air is then mixed in the combustion blower and sent through the transition tube into the burner. The Direct Spark Ignition System (DSI) then ignites the gas/air fuel mixture to produce flue products (combustion). The flame sensor signals the ignition control board (described below), that a flame is present.

ICON SYSTEM INTEGRATED CONTROL

Consists of a control board and a water heater display. An attractive digital water heater display is on the top front of the water heater for precisely setting and displaying the temperature setpoint and monitoring the status of the water heater. Pressing the temperature UP and DOWN buttons changes the temperature setpoint. The temperature format may be displayed in degrees F or *degrees C*. The water heater display will show diagnostic codes in the event the water heater needs servicing. The temperature readings of the tank sensor can be monitored in Service Mode. Also, in-Service Mode, the display can show up to 10 previous error codes to further aid in servicing the water heater. The single control board has plug in wiring harnesses to reduce the chance of miswiring. The control board controls all ignition, temperature, and combustion blower functions. The control board controls the combustion blower, ignition timings, and gas valve to control the combustion system in order to maintain the desired tank temperature. The sequence of operation is described in detail in the Diagnostic Section at the back of this Installation and Operation Manual.

ADJUSTABLE THERMOSTAT

This water heater is equipped with an adjustable thermostat as part of the Integrated Control System to control water temperature. Hot water temperatures required for automatic dishwasher and laundry use can cause scald burns resulting in serious personal injury and/or death.

The temperature may be adjusted from about 70°F (21°C) to about 180°F (82°C). The thermostat was adjusted to 70°F (21°C) before the water heater was shipped from the factory. It is recommended that lower temperatures be used to avoid the risk of scalding. Refer to the “Warnings” and the section on SCALDING in “Section V: Water Connections”. It is further recommended, in all cases, that the water temperature be set for the lowest temperature, which satisfies your hot water requirements for the installation. This will also provide the most energy efficient operation of the water heater and minimizes scale formation.

Setting the water heater temperature at 120°F (49°C) will reduce the risk of scalds. Some states require setting lower temperatures for specific installations.

The top immersion well of the single sensor control also contains a redundant sensor for the high limit (energy cutoff). The high limit circuit interrupts the main burner gas flow should the water temperature exceed approximately 200°F (93°C). Error code “65” will be shown on the water heater control display if the high limit temperature has been exceeded.

Should the high limit switch activate, it must be manually reset. This should only be done by a service technician after the cause of overheating has been corrected. Refer to the section on “Accessing Service Mode on the Display” in the Diagnostic section of this Installation and Instruction Manual.

Contact your qualified installing contractor, service provider or manufacturer listed on the rating plate if continued high limit operation occurs.

SERVICE PANEL

The service panel is located behind the service panel access cover, which is located by the exhaust elbow near the bottom of the water heater. This panel contains a pressure switch that monitors the pressure in the exhaust pipe in case the vent terminal becomes blocked. A collector high limit switch is used to monitor the ambient temperature between the first pass collector and the exhaust collector. This is a manually re-settable switch. If this switch continues to trip, please contact an authorized service agency.

LATCHES

The latches allow easy access for servicing the water heater from the top. Simply remove the two latches for servicing and re-latch upon completion. No tools are required to obtain access to the top of the water heater.

⚠ WARNING

Keep clear of the combination temperature and pressure relief valve discharge line outlet. The discharge may be hot enough to cause scald injury. The water is under pressure and may splash.

For protection against excessive temperatures and pressure, install temperature and pressure protective equipment required by local codes, but not less than a combination temperature and pressure relief valve certified by a nationally recognized testing laboratory that maintains periodic inspection of production of listed equipment.

Install the combination temperature and pressure relief valve into the opening provided and marked for this purpose on the water heater.

Note: Some models may already be equipped or supplied with an installed combination temperature and pressure relief valve. Verify that the combination temperature and pressure relief valve complies with local codes. If the combination temperature and pressure relief valve does not comply with local codes, replace it with one that does. Follow the installation instructions above on this page

Install a discharge line so that water discharged from the combination temperature and pressure relief valve will exit within six (6) inches (15.2 cm) above, or any distance below the structural floor and cannot contact any live electrical part. The discharge line is to be installed to allow for complete drainage of both the combination temperature and pressure relief valve and the discharge line. The discharge opening must not be subjected to blockage or freezing. **DO NOT** thread, plug or cap the discharge line. It is recommended that a minimum clearance of four (4) inches (10.2 cm) be provided on the side of the water heater for servicing and maintenance of the combination temperature and pressure relief valve.

Do not place a valve between the combination temperature and pressure relief valve and the tank!

CONDENSATE DRAIN – The water heater should either be raised several inches above the floor on a concrete slab or use a low-profile condensate pump to allow free drainage of condensate from the elbow drain fitting. This water heater is a condensing type unit and requires a drain to be located in close proximity to allow the condensate to drain safely. The condensate drains from the unit at the exhaust elbow located near the bottom of the unit. The preferred connection to the drain fitting is to use a $\frac{3}{4}$ (1.9 cm) inch PVC elbow sealed with silicone over the outside of the drain outlet and use $\frac{3}{4}$ inch (1.9 cm) PVC for the drain trap and condensate line to a drain. Use a thick bead of silicone caulk over the outside of the drain outlet connection before assembling the elbow. This is preferred over using the threaded tap because the larger drain line will drain more freely and if too much force is applied to the plastic threads, the fitting may crack and cause a leak. Make sure the condensate drain line slopes down, away from the water heater at least $\frac{1}{8}$ inch (.3 cm) per foot (.3 m) toward the drain. The condensate drainpipe must not be routed through an area subject to below freezing temperatures. The condensate build-up will block the exhaust outlet, which will cause improper operation. Refer to Figure 2 for the proper connection of a PVC elbow to the drain outlet and a condensate trap.

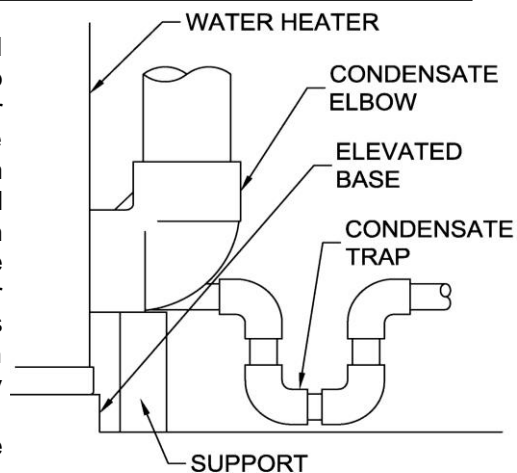

Figure 2. Condensate Elbow With Trap. Elevated Base Recommended.

CLEANOUT – All models are equipped with a cleanout opening to aid in removal of hard water deposits from the tank bottom. If this water heater operates under hard water conditions, the following should be performed at least every 3 months: Turn off water supply and drain the water heater. Remove the cleanout jacket cover and tank cover. When cleaning the tank, care must be taken to avoid trying to break deposits loose as this could damage the glass lining and shorten the life of the water heater. After cleaning, re-install the cleanout tank cover and jacket cover, and refill with water. Refer to the section, “Section X – Maintenance” in this Installation and Operating Instruction manual for the procedures for filling and draining the water heater.

SECTION IV: INSTALLATION INSTRUCTIONS

WARNING

INSTALLATION OF THIS WATER HEATER REQUIRES ABILITY EQUIVALENT TO THAT OF A LICENSED TRADESMAN IN THE FIELD INVOLVED. PLUMBING, AIR SUPPLY, VENTING, GAS SUPPLY AND ELECTRICAL WORK ARE REQUIRED.

DO NOT ATTEMPT TO LIGHT ANY GAS APPLIANCE IF YOU ARE NOT CERTAIN OF THE FOLLOWING:

- Liquefied petroleum gases/propane gas and natural gas have an odorant added by the gas supplier that aids in detection of the gas.
- Most people recognize this odor as a “sulfur” or “rotten egg” smell.
- Other conditions, such as “odorant fade” can cause the odorant to diminish in intensity, or “fade”, and not be as readily detectable.
- If you have a diminished sense of smell or are in any way unsure of the presence of gas, immediately contact your gas supplier from a telephone in another building.
- Gas detectors are available. Contact your gas supplier or plumbing professional for more information.

Liquefied petroleum gases/propane gas is heavier than air and will remain at floor level if there is a leak. Basements, crawl spaces, closets and areas below ground level will serve as pockets for accumulation of leaking gas. Before lighting, smell all around the appliance area for gas. Be sure to smell next to the floor.

IF YOU SMELL GAS:

- Do not try to light any appliance.
- Do not touch any electric switch; do not use any telephone in your building.
- Immediately call your gas supplier from a telephone in another building. Follow the gas supplier’s instructions.
- If you cannot reach your gas supplier, call the fire department.

DO NOT OPERATE THE APPLIANCE UNTIL THE LEAKAGE IS CORRECTED!

WARNING

This water heater must be located in an area where leakage of the tank, water line connections, or the combination temperature and pressure relief valve will not result in damage to the area adjacent to the water heater or to lower floors of the structure. When such locations cannot be avoided, a suitable drain pan must be installed under the water heater. The drain pan depth must be suitable for draining and collecting water and have a minimum length and width of at least four (4) inches (10.0 cm) measured from the jacket of the water heater. The drain pan, as described above, can be purchased from your plumbing professional. The drain pan must be piped to an adequate drain. The piping must be at least 3/4 inch (2.0 cm) in diameter and pitched for proper drainage.

This water heater MUST be installed indoors out of the wind and weather.

This water heater MUST NOT be installed in any location where gasoline or flammable vapors are likely to be present, unless the installation is such to eliminate the probable ignition of gasoline or flammable vapors.

UNPACKING

INSPECT SHIPMENT

1. Inspect carefully for any signs of damage.
2. All equipment is carefully manufactured, inspected and packed.
3. Any claims for damage or shortage in shipment must be filed immediately with manufacturer and noted on the Bill of Lading.
4. Remove all venting components from the combustion assembly compartment by removing the latches and tek screws.

NOTICE

The vent terminals and the condensate elbow that is supplied with this water heater are stored at the top in the Combustion Assembly Compartment. To access the vent terminals and condensate elbow, unfasten the top lid and remove parts. Be sure to replace the top lid and fastened.

LOCATE WATER HEATER in front of final position before removing crate.

1. LOCATE so that venting connections will be short and direct.
2. THIS WATER HEATER IS SUITABLE FOR INSTALLATION ON COMBUSTIBLE FLOOR. Do not install this water heater on carpeting.
3. FOR BASEMENT INSTALLATION, provide a solid level elevated base such as concrete.
4. Minimum clearance to combustible material is 0 cm for the Top, Sides, and Rear of this water heater. However, it is recommended that **at least 46 cm from the Top, 61 cm from the Front, and 10 cm for the Sides, and Rear of the water heater be provided for servicing.** Clearance for servicing may be reduced down to minimum clearance to combustible material, but service time and effort may be greatly increased.

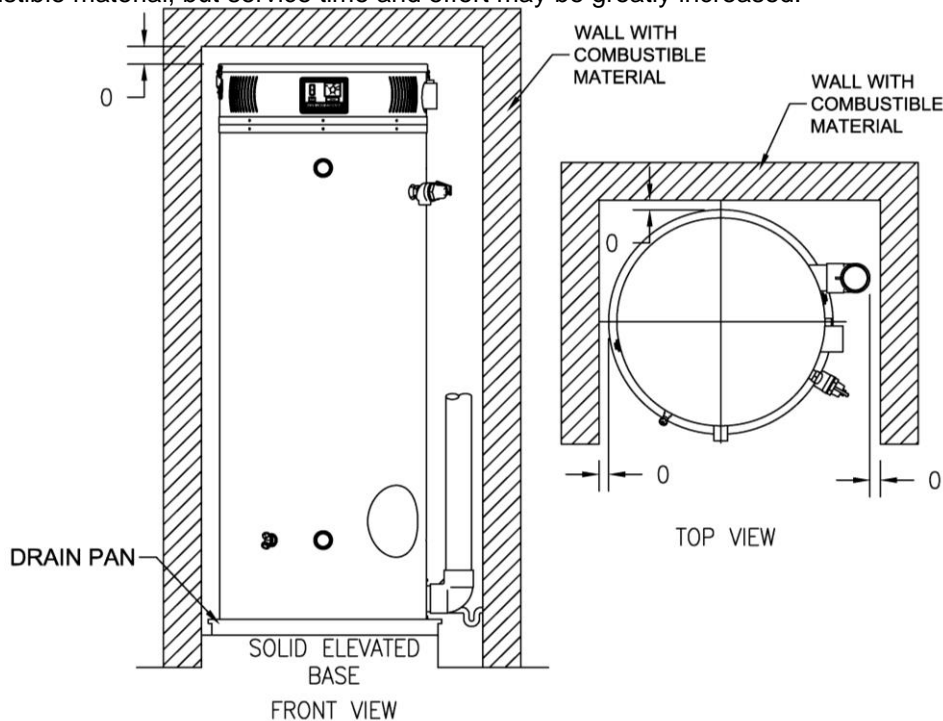

Figure 3. Minimum Clearance To Combustible

REMOVE CRATE

1. Remove all banding and pry off crate sides carefully so as not to damage the water heater.
2. Carefully roll/lift the water heater from the crate base.

CAUTION

Do not drop water heater. Do not bump water heater jacket against floor.

Do not bump exhaust vent pipe against crate or other objects. This will damage the heater and cause it to be inoperable or create nuisance problems.

MOVE WATER HEATER TO PERMANENT POSITION by sliding or walking. Place drain pan underneath water heater. **INSTALL TEMPERATURE AND PRESSURE RELIEF VALVE** (if not already installed).



CAUTION

If building cold water supply has a back-flow preventer, check valve or water meter with check valve, provisions for thermal expansion of water in the hot water system must be provided.



DANGER

Temperature setting should not exceed safe temperature at fixtures. See water temperature control warning on page 16. If higher preheat temperatures are necessary to obtain adequate booster output, add an anti-scald valve for hot water supplied to fixtures.



WARNING

Temperature and pressure relief valve discharge piping must be piped near floor to eliminate potential of severe burns. Do not pipe in any area where freezing could occur. Do not install any shut-off valves, plugs or caps to the temperature and pressure relief valve or piping.

LOCATION

KEEP APPLIANCE AREA CLEAR AND FREE OF COMBUSTIBLE MATERIALS, GASOLINE AND OTHER FLAMMABLE VAPORS AND LIQUIDS.

This water heater must be located in an area where the general public does not have access to set temperatures.

AIR REQUIREMENTS

1. Do not obstruct the flow of combustion and ventilating air.
2. For safe operation, adequate air is needed for combustion and ventilation. Sooting may result in serious damage to the water heater and risk of fire or explosion. It can also create a risk of asphyxiation. Such a condition often will result in a yellow, luminous burner flame, causing carboning or sooting of the combustion chamber, burner and flue tubes.

MECHANICAL EXHAUSTING OF ROOM AIR

1. Where an exhaust fan is installed in the same room with this water heater and combustion air is drawn from inside the room, sufficient openings for air must be provided in the walls. **UNDERSIZED OPENINGS WILL CAUSE AIR TO BE DRAWN INTO THE ROOM THROUGH THE WATER HEATER'S VENTING SYSTEM, CAUSING POOR COMBUSTION THAT MAY BE HAZARDOUS TO LIFE. SOOTING MAY RESULT IN SERIOUS DAMAGE TO THE WATER HEATER AND RISK OF FIRE OR EXPLOSION, WHICH CAN ALSO CREATE A RISK OF ASPHYXIATION.** Refer to local codes and /or national codes for proper air opening sizing.

UNCONFINED SPACE

1. In buildings of conventional frame, brick or stone construction, unconfined spaces may provide adequate air for combustion and ventilation.
2. If the unconfined space is within a building of tight construction (buildings using the following construction: weather stripping, heavy insulation, caulking, vapor barrier, etc.), air for combustion and ventilation must be obtained from outdoors. This may be accomplished by piping air directly to the water heater from outside or providing opening or ducts in the wall. The installation instructions for confined spaces in tightly constructed buildings must be followed to ensure adequate air supply.

CONFINED SPACE

1. When drawing combustion air from inside a conventionally constructed building to a confined space, such a space shall be provided with two permanent openings.
 - The top opening is to be located within 30.5 cm of the enclosure top and the bottom opening within 30.5 cm of the enclosure bottom.
 - Each opening shall have a free area of at least 6.5 square cm per 293 watts of the total input of all appliances in the enclosure, but not less than 645 square cm.

2. If the confined space is within a building of tight construction, air for combustion and ventilation must be obtained from outdoors. This may be accomplished by piping air directly to the water heater from outside or providing opening or ducts in the wall. When directly communicating with the outdoors through vertical ducts, two permanent openings, located in the above manner, shall be provided.
 - Each opening shall have a free area of not less than 6.5 square cm per 1172 watts of the total input of all appliances in the enclosure.
 - If horizontal ducts are used, each opening shall have a free area of not less than 6.5 square cm per 586 watts of the total input of all appliances in the enclosure.
3. If the water heater is installed as a direct vent (outside air piped directly to the water heater), then additional opening, other than the opening for the air intake, are not required. However, adequate ventilation air must be provided in all cases to prevent increased room temperature.

CHEMICAL VAPOR CORROSION

Corrosion of the flue ways and vent system will occur if air for combustion contains certain chemical vapors. Such corrosion may result in poor combustion and create a risk of asphyxiation. Spray can propellants, cleaning solvents, refrigerator and air conditioning refrigerants, swimming pool chemicals, calcium and sodium chloride, waxes and process chemicals are corrosive. Products of this sort should not be stored near the water heater or outside by the air intake (if applicable).

TYPICAL INSTALLATION ILLUSTRATION



CAUTION

If building cold water supply has a back-flow preventer, check valve, or water meter with check valve provisions for thermal expansion of water in the hot water system must be provided.

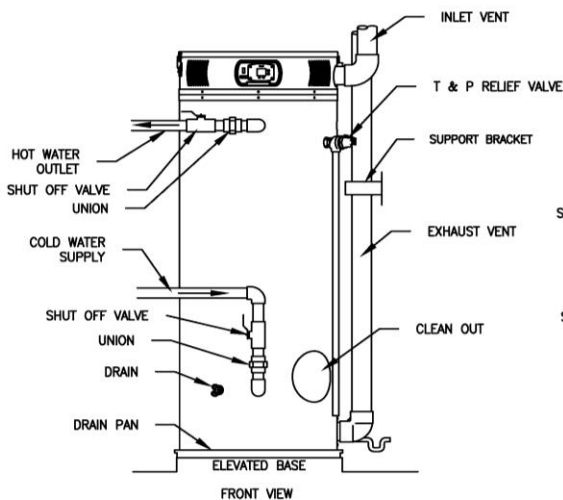

Figure 4. Typical Front Inlet Connection

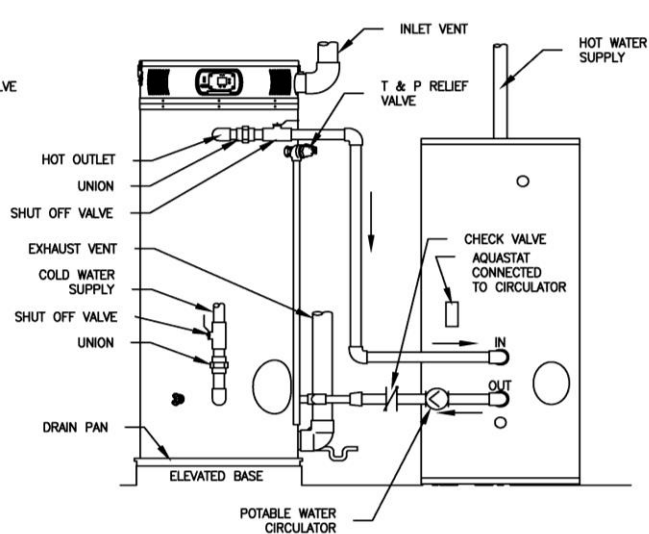

Figure 5. Typical Front Inlet Connect with Storage Heater.

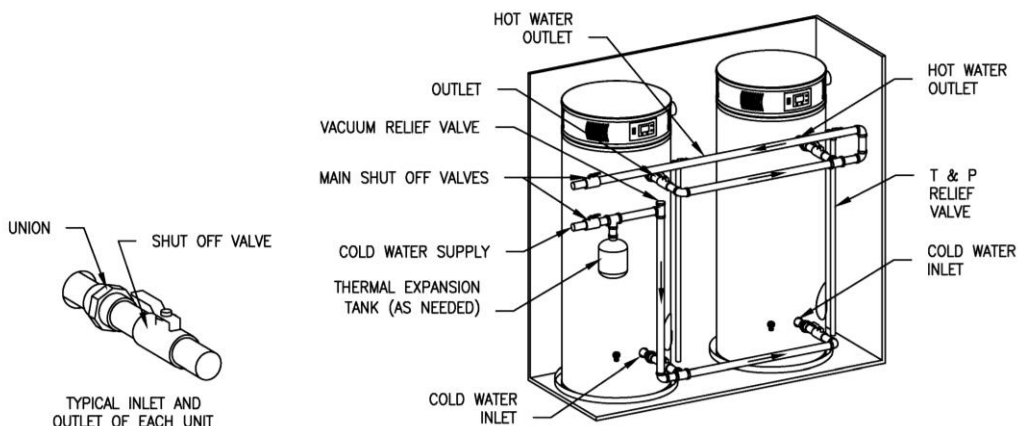

Figure 6. Typical Two Water Heater Connection.

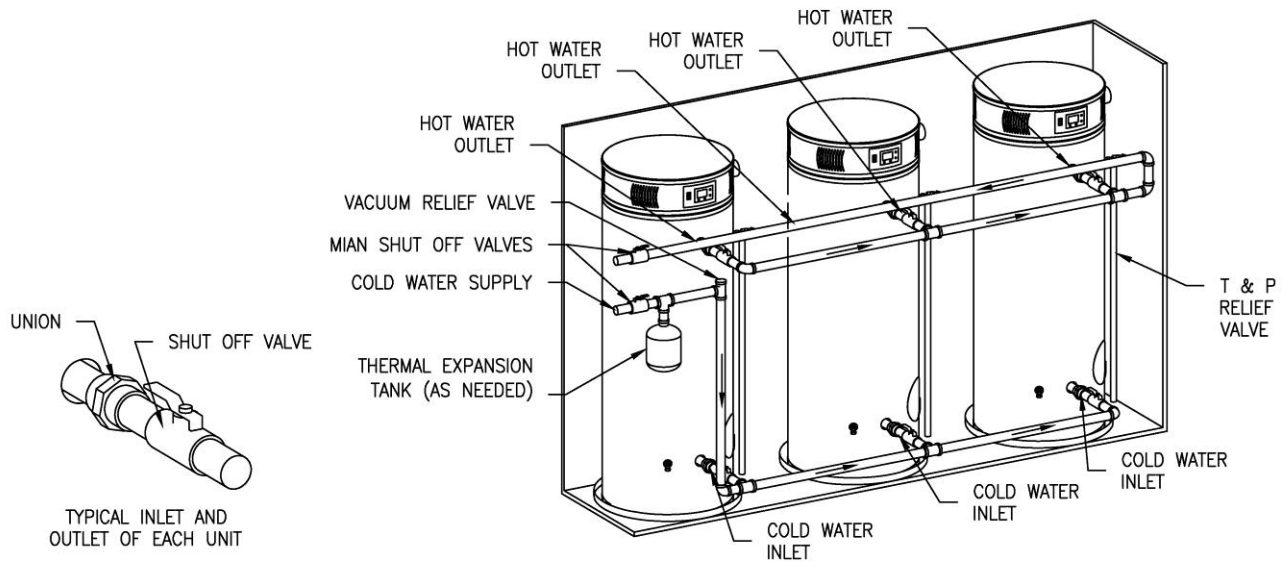

Figure 7. Typical Three-Water Heater Connection

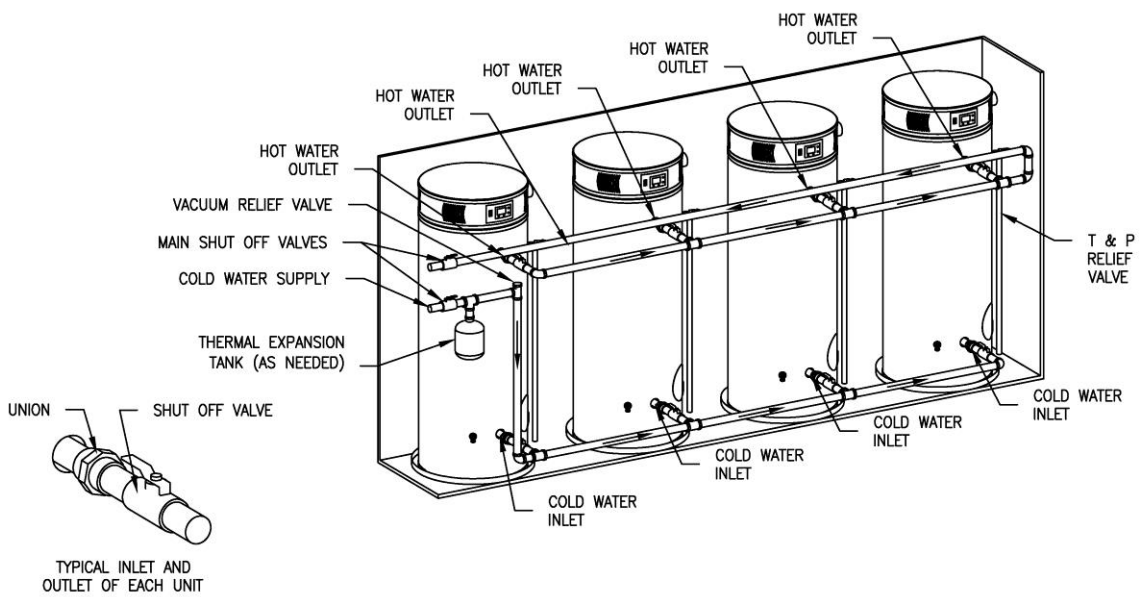

Figure 8. Typical Four-Water Heater Connection

SECTION V: WATER CONNECTIONS

WARNING

Failure to install and maintain a new, listed temperature and pressure relief valve will release the manufacturer from any claim, which might result from excessive temperature and pressures.

Hydrogen gas can be produced in an operating water heater that has not had water drawn from the tank for a long period of time (generally two weeks or more). **HYDROGEN GAS IS EXTREMELY FLAMMABLE.** To prevent the possibility of injury under these conditions, we recommend the hot water faucet to be open for several minutes at the kitchen sink before you use any electrical appliance, which is connected to the hot water system. If hydrogen is present, there will be an unusual sound such as air escaping through the pipes as hot water begins to flow. Do not smoke or have open flame near the faucet at the time it is open.

Keep clear of the combination temperature and pressure relief valve discharge line outlet. The discharge may be hot enough to cause scald injury. The water is under pressure and may splash.

CAUTION

If sweat fittings are to be used, **DO NOT** apply heat to the nipples in front or side of the water heater. Sweat the tubing to the adapter before fitting the adapter to the water connections. It is imperative that heat is not applied to the nipples containing a plastic liner.

INSTRUCTIONS FOR CONNECTIONS

1. **BEFORE PROCEEDING WITH THE INSTALLATION, CLOSE THE MAIN WATER SUPPLY VALVE.** After shutting off the main water supply, open a faucet to relieve the water line pressure to prevent any water from leaking out of the pipes while making the water connections to the water heater. The **COLD** water inlet and **HOT** water outlet are identified on the water heater. Make the proper plumbing connections between the water heater and the plumbing system to the building. Install a shut-off valve in the cold water supply line.
2. If this water heater is installed in a closed water supply system, such as the one having a back-flow preventer in the cold water supply, provisions must be made to control thermal expansion. **DO NOT OPERATE** this water heater in a closed system without provisions for controlling thermal expansion. Warranties do not cover damages from thermal expansion such as pressure bulges and/or deformities. Your water supplier or local plumbing inspector should be contacted on how to control this situation.
3. After installation of the water lines, open the main water supply valve and fill the water heater. While the water heater is filling, open several hot water faucets to allow air to escape from the water system. When steady streams of water flow through the faucets, close them, and check all water connections for possible leaks.
4. Never operate the water heater without first being certain it is filled with water.

SCALDING

This water heater can deliver scalding temperature water at any faucet in the system. Be careful whenever using hot water to avoid scalding injury. Certain appliances such as dishwashers and automatic clothes washers may require increased temperature water. By setting the thermostat on this water heater to obtain the increased temperature water required by these appliances, you might create the potential for scald injury. To protect against injury, you should install an ASSE approved mixing valve in the water system. This valve will reduce point of discharge temperature by mixing cold and hot water in branch supply lines. Such valves are available from the local plumbing supplier. The following chart details the relationship of water temperature and time with regard to scald injury and may be used as a guide in determining the safest water temperature for your applications.

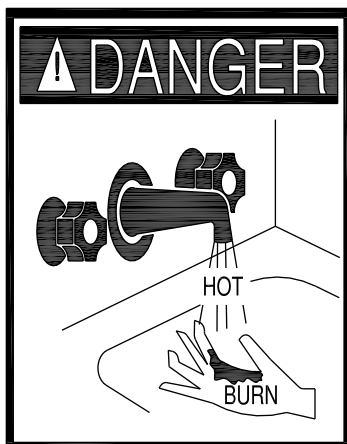
	<p>Water temperature over 125°F (52°C) can cause severe burns instantly or death from scalds.</p> <p>Children, disabled and elderly are at highest risk of being scalded.</p> <p>Review this instruction manual before setting temperature at water heater.</p> <p>Feel water before bathing or showering.</p> <p>Temperature limiting valves are available, contact local plumbing supplier.</p>
--	---

Approximate Time/Temperature Scald Chart

APPROXIMATE TIME/TEMPERATURE RELATIONSHIPS IN SCALDS	
120°F (49°C)	More than 5 minutes
125°F (52°C)	1½ to 2 minutes
130°F (54°C)	About 30 seconds
135°F (57°C)	About 10 seconds
140°F (60°C)	Less than 5 seconds
145°F (63°C)	Less than 3 seconds
150°F (65°C)	About 1½ seconds
155°F (68°C)	About 1 second

Table 2.

ALTERNATE SPACE HEATING WATER CONNECTIONS

! DANGER

Toxic chemicals, such as those used for boiler treatment, **shall not** be introduced into potable water used for space heating.

This water heater **must not** be connected to an existing heating system or component(s) previously used with a non-potable water heating appliance.

All piping components connected to this water heater for space-heating applications must be suitable for use with potable water.

! WARNING

When the system requires water for space heating at temperatures higher than required for other uses, a means such as an ASSE approved mixing valve shall be installed to temper the water for those uses in order to reduce scald hazard potential.

Failure to properly pipe this water heater may result in improper operation and damage to the water heater or structure.

Oxygen contamination of this water heater will cause corrosion of iron and steel components, and can lead to water heater failure.

Connect the system supply and return piping to the water heater.

Refer to Figure 9 and Figure 10 for installation examples. Maintain a minimum 1.27 cm clearance from hot water piping to combustible materials.

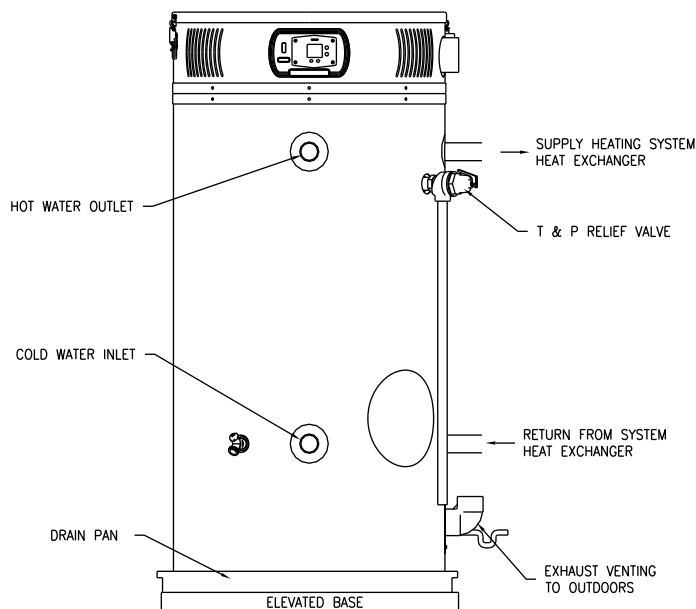

Figure 9. Alternate Space Heating Connections

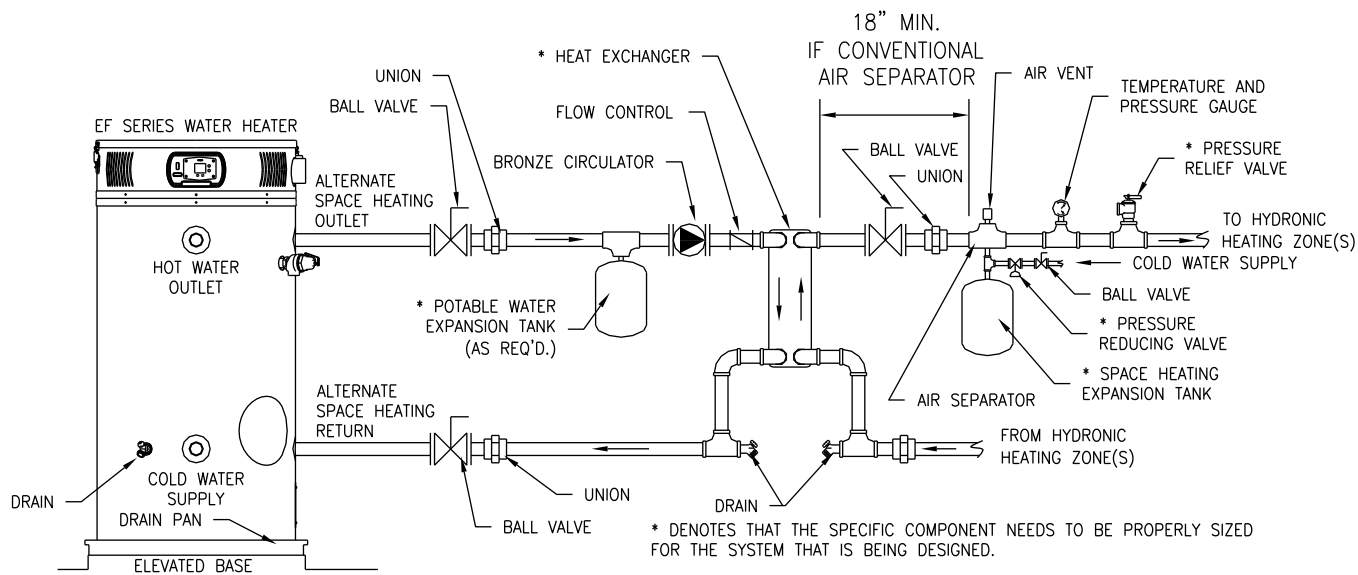

Figure 10. Typical Plumbing Schematic for Zoned Heating

SECTION VI: VENTING

! WARNING

The vent system must be properly installed in accordance with the water heater manufacturer's instructions. Failure to properly install the vent system could result in property damage, personal injury, or death.

DO NOT install damaged venting system components. If damage is evident then please contact the supplier where the water heater was purchased or the manufacturer listed on the rating plate for replacement parts.

Use only the vent terminals provided or factory authorized terminals for venting this water heater.

The water heater requires its own separate venting system. Do not connect the exhaust vent into an existing vent pipe or chimney.

All of the exhaust venting connections must be leak checked with a soap solution upon initial startup of the water heater. Any leaks must be repaired before continuing operation of the water heater.

Do not terminate the venting where noise from the exhaust or intake will be objectionable. This includes locations close to or across from windows and doors. Avoid anchoring the vent and intake pipes directly to framed walls, floors, or ceilings unless rubber isolation pipe-hangers are used. This prevents any vibrations from being transmitted into the living spaces.

Do not exceed the venting distances or the number of elbows listed in this manual. Exceeding the maximum venting distances may cause the water heater to malfunction or cause an unsafe condition.

DO NOT operate this water heater until the venting installation is complete and the piping completed. Failure to complete installation before operation can result in property damage, personal injury, or death.

! CAUTION

Check to make sure flue gases do not recirculate into the air intake terminal when using direct venting. If the water heater is having service issues, flue recirculation may be a contributing factor. Even when the minimum vent terminal separation distances are followed, recirculation may still occur depending upon the location outside the building, the distance from other buildings, proximity to corners, weather conditions, wind patterns, and snow depth. Periodically check to make sure that flue recirculation is not occurring. Signs of flue gas recirculation include frosted or frozen intake terminals, condensate in the intake terminal and venting system, oxidation or white chalk material on the flame sensor or igniter shield. Correction to flue recirculation may involve angling the intake and exhaust away from each other, increasing the distance between them, relocating the air intake to another side of the building, or using inside air for combustion.

Check to be sure the intake and exhaust terminals are not obstructed, especially during periods of below freezing weather.

All intake and exhaust venting components **must** have the same diameter size. **Do not** use a different size on the intake and exhaust venting.

Be sure the condensate runs freely to a drain and does not accumulate inside the water heater. In cold climates, precautions may need to be taken to ensure that the condensate drain does not freeze. Make sure the condensate trap or drain loop is installed to prevent flue gases from being discharged into the room. Refer to the Venting section of the Installation and Operating Instructions Manual for complete instructions on venting and condensate drainage.

⚠ CAUTION

The vent shall terminate a minimum of 30.5 cm above expected snowfall level to prevent blockage of vent termination.

A service drain loop must be installed in the drain tubing to serve as a condensate trap to prevent flue gases from escaping in the room.

DO NOT position air intake terminal above exhaust terminal.

NEVER locate air intake terminal when exhaust gases can be introduced.

Approved Venting Materials

For installations in the US only

- PVC DWV (ASTM D-2665)
- PVC Sch. 40 (ASTM-D1785)
- CPVC Sch. 40 (ASTM-F441, ASTM-D2846)
- PVC and CPVC (UL 1738, ULC S636)
- ABS Sch. 40 DWV (ASTM-D2661)
- Polypropylene (UL 1738, ULC S636)
- Stainless Steel (UL 1738, ULC S636)

For installations in CANADA

- ULC S636 approved PVC for flue gas venting rated Class II, 65°C
- ULC S636 approved CPVC for flue gas venting rated Class II, 65°C
- ULC S636 approved Polypropylene for flue gas venting rated Class II, 65°C
- Stainless Steel (ULC S636)

Approved Primers and Cements

For installations in the US only

- PVC and CPVC Primer (ASTM-F656)
- PVC Cement (ASTM D-2564)
- CPVC Cement (ASTM F493)
- ABS Primer and Cement (ASTM D-2235)

For installations in CANADA

- ULC S636 approved Primer and Cement for flue gas venting rated Class II, 65°C

NOTICE

Before beginning installation of any vent pipe, read the vent pipe manufacturer's installation instructions.

Water heater must be protected from freezing downdrafts during shutdown periods

Provide protection of the building materials from degradation by flue gases from the exhaust vent terminal.

VENTING

The venting instructions must be followed to avoid restricted combustion or recirculation of flue gases. Such conditions cause sooting, risks of fire, and/or asphyxiation.

This water heater can be installed as either a direct vent system or power vent (vent category B) system. If it is installed as a direct vent system, then the air intake and the exhaust vent are piped to the outside. If a power vented system is used, then air is drawn from inside and only the exhaust is piped to the outside. Determine which system is best for your application and install as described in the following sections.

DIRECT VENT INSTALLATION

Venting may be run horizontally through an outside wall or vertically through a roof, using 3-inch (7.6 cm) or 4-inch (10.2 cm) diameter PVC, ABS, or CPVC vent pipe. This water heater is supplied with a screened intake elbow and exhaust coupling referred to as the air intake terminal and the exhaust vent terminal.

NOTICE

If 4" (10.2 cm) PVC, ABS, or CPVC vent pipe is used, then use a 4" (10.2 cm) to 3" (7.6 cm) PVC, ABS, or CPVC reducer to connect to the supplied screened intake and 90° exhaust elbow.

DIRECT VENT TERMINAL LOCATION

Plan the vent system layout so that proper clearances are maintained from plumbing and wiring. Before the vent is installed, determine the vent pipe termination location as shown in Figure 11.

NOTICE

Use of cellular core PVC (ASTM F891). Cellular core CPVC, or Radel® (polyphenylsulfone) in non-metallic venting systems is prohibited and covering non-metallic venting with thermal insulation is prohibited.

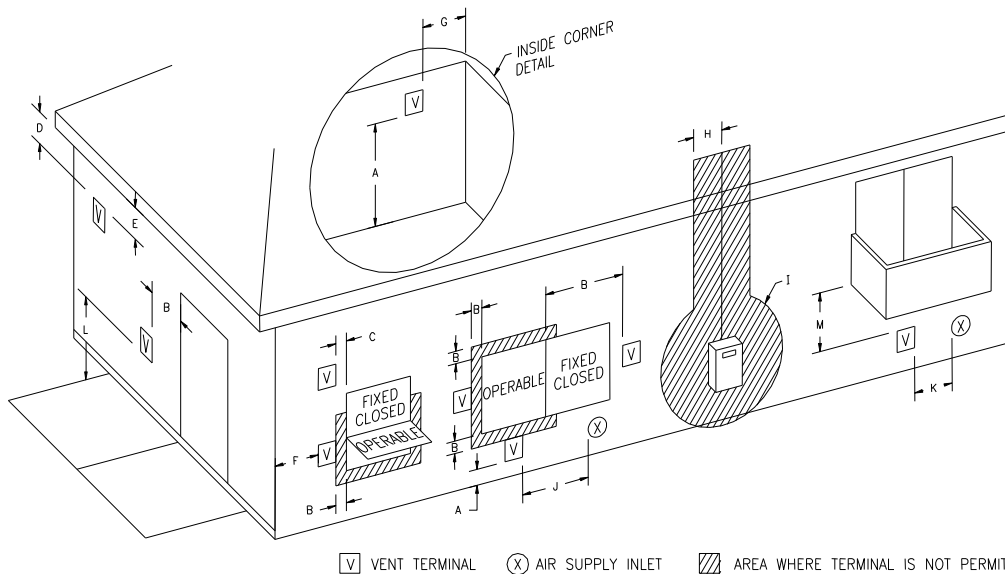

Figure 11a. Vent Terminal Clearances (Other than Direct Vent or “Power Vented” Installations)

	Canadian Installations ¹	US Installations ²		Canadian Installations ¹	US Installations ²
A= Clearance above grade, veranda, porch, deck or balcony	12 inches (30 cm)	12 inches (30 cm)	H=	Clearance to each side of center line extended above meter/regulator assembly	3 feet (91 cm) within a height 15 feet (4.6 m) above the meter/regulator assembly
B= Clearance to window or door that may be opened	6 in (15cm) for appliances ≤10,000 Btuh (3kW); 12 in (30 cm) for appliances >10,000 Btuh (3kW) and ≤100,000 Btuh (30kW); 36 in (91 cm) for appliances >100,000 Btuh (30 kW)	4 feet (1.2 m) below or to the side of opening; 12 inches (30 cm) above opening	I=	Clearance to service regulator vent outlet or oil tank vent	36 inches (91 cm)
C= Clearance to permanently closed window	*b	*b	J=	Clearance to non-mechanical air supply inlet to building or the combustion air inlet to any other appliance	6 in (15cm) for appliances ≤10,000 Btuh (3kW); 12 in (30 cm) for appliances >10,000 Btuh (3kW) and ≤100,000 Btuh (30kW); 36 in (91 cm) for appliances >100,000 Btuh (30 kW)
D= Vertical clearance to ventilated soffit located above the terminal within a horizontal distance of 2 feet (.6 m) from the center line of the terminal	*b	*b	K=	Clearance to a mechanical air supply inlet	3 feet (.9 m) above if within 10 feet (3 m) horizontally
E= Clearance to unventilated soffit	*b	*b	L=	Clearance above paved sidewalk or paved driveway located on public property	7 feet (2.13 m) †
F= Clearance to outside corner	*b	*b	M=	Clearance under a veranda, porch, deck, or balcony	12 inches (30 cm) ‡
G= Clearance to inside corner	36 inches (91 cm) *a	36 inches (91 cm) *a			*b

¹ In accordance with the current CAN/CGA-B149 *Installation Codes*.

² In accordance with the current ANSI Z223.1-(Latest Edition)/NFPA 54 *National Fuel Gas Code*.

† A vent shall not terminate directly above a sidewalk or paved driveway that is located between two single-family dwellings and serves both dwellings.

‡ Permitted only if a veranda, porch, deck or balcony is fully open on a minimum of two sides beneath the floor.

*a) A minimum clearance value determined by testing in accordance with section 2.20.

*b) “Clearance in accordance with local installation codes and the requirements of the gas supplier”.

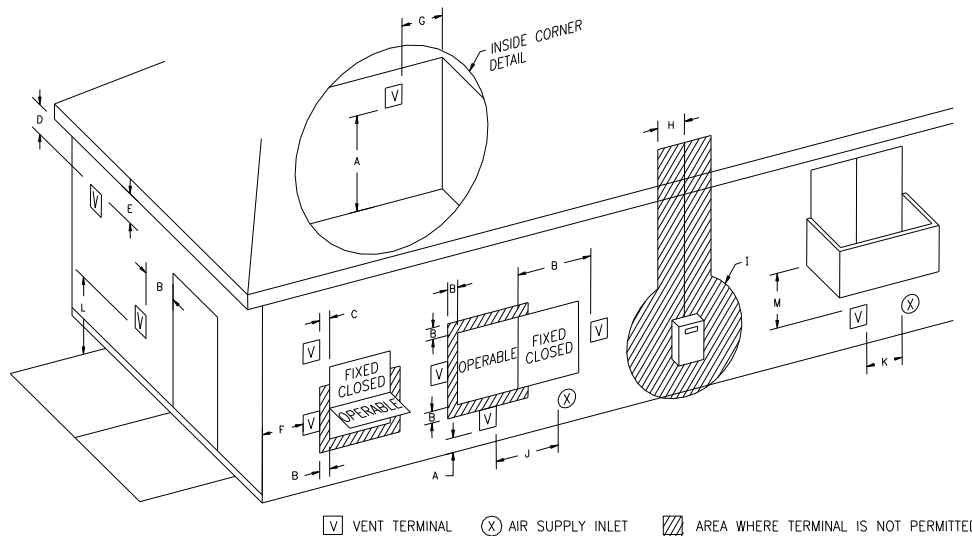

Figure 11b. Direct Vent Terminal Clearances

	Canadian Installations ¹	US Installations ²		Canadian Installations ¹	US Installations ²		
A=	Clearance above grade, veranda, porch, deck or balcony	12 inches (30 cm)	12 inches (30 cm)	H=	Clearance to each side of center line extended above meter/regulator assembly	3 feet (91 cm) within a height 15 feet (4.6 m) above the meter/regulator assembly	*b
B=	Clearance to window or door that may be opened	6 in (15cm) for appliances ≤10,000 Btuh (3kW); 12 in (30 cm) for appliances >10,000 Btuh (3kW) and ≤100,000 Btuh (30kW); 36 in (91 cm) for appliances >100,000 Btuh (30 kW)	6 in (15 cm) for appliances ≤10,000 Btuh (3 kW); 9 in (23 cm) for appliances >10,000 Btuh (3 kW) and ≤ 50,000 Btuh (15 kW); 12 in (30 cm) for appliances >50,000 Btuh (15 kW)	I=	Clearance to service regulator vent outlet or oil tank vent	36 inches (91 cm)	*b
C=	Clearance to permanently closed window	*b	*b	J=	Clearance to non-mechanical air supply inlet to building or the combustion air inlet to any other appliance	6 in (15cm) for appliances ≤10,000 Btuh (3kW); 12 in (30 cm) for appliances >10,000 Btuh (3kW) and ≤100,000 Btuh (30kW); 36 in (91 cm) for appliances >100,000 Btuh (30 kW)	6 in (15 cm) for appliances ≤10,000 Btuh (3 kW); 9 in (23 cm) for appliances >10,000 Btuh (3 kW) and ≤ 50,000 Btuh (15 kW); 12 in (30 cm) for appliances >50,000 Btuh (15 kW)
D=	Vertical clearance to ventilated soffit located above the terminal within a horizontal distance of 2 feet (.6 m) from the center line of the terminal	12 inches (30 cm) *a	12 inches (30 cm) *a	K=	Clearance to a mechanical air supply inlet	6 feet (1.83 m)	3 feet (.9 m) above if within 10 feet (3 m) horizontally
E=	Clearance to unventilated soffit	12 inches (30 cm) *a	12 inches (30 cm) *a	L=	Clearance above paved sidewalk or paved driveway located on public property	7 feet (2.13 m) †	*b
F=	Clearance to outside corner	*b	*b	M=	Clearance under a veranda, porch, deck, or balcony	12 inches (30 cm) ‡	*b
G=	Clearance to inside corner	36 inches (91 cm) *a	36 inches (91 cm) *a				

¹ In accordance with the current CAN/CGA-B149 *Installation Codes*.

² In accordance with the current ANSI Z223.1-(Latest Edition)/NFPA 54 *National Fuel Gas Code*.

† A vent shall not terminate directly above a sidewalk or paved driveway that is located between two single-family dwellings and serves both dwellings.

‡ Permitted only if a veranda, porch, deck or balcony is fully open on a minimum of two sides beneath the floor.

*a) A minimum clearance value determined by testing in accordance with section 2.20.

*b) "Clearance in accordance with local installation codes and the requirements of the gas supplier".

Vent terminals must terminate at least 3 feet (1 m) above any forced air inlet located within 10 feet (3.1 m). This provision does not apply to:

1. The combustion air intake of a direct vent appliance or the circulating air inlet and flue gas discharge of listed outdoor appliances.
2. The exhaust vent terminal must be installed with at least 12 inches (30.5 cm) clearance from any air opening into a building.
3. The bottom of the exhaust vent and combustion air intake terminals must be located at least 12 inches (30.5 cm) above grade and above the anticipated snow level.
4. Must be installed at least 3 feet (1 m) from any gas meter, gas valve or other gas regulating equipment. Must be installed in a location where it will not be blocked by snow.
5. The exhaust vent and combustion air intake terminals must be installed so that the centerline distances are at least 36 inches (91.4cm) apart and the exhaust vent terminal elbow extends 6 inches (15.2 cm) past the combustion air intake terminal.

EXCEPTIONS FOR INSTALLATIONS

The vent terminal must not terminate (refer to national and local standards):

1. Directly above a paved sidewalk or paved driveway which is located between two single-family dwellings and serves both dwellings;
2. Less than 7 feet (2.1 m) above a paved sidewalk or a paved driveway located on public property;
3. Within 6 feet (1.8 m) of a mechanical air supply inlet to any building;
4. Above a gas meter/regulator assembly within 3 feet (0.9 m) horizontal of the vertical centerline of the regulator;
5. Within 6 feet (1.8m) of any gas service regulator vent outlet;
6. Less than 1 foot (30.5 cm) above grade level;
7. Within 12 inches (30.5 cm) of a window or door, which can be opened in any building, any non-mechanical air, supply inlet to any building or the combustion air inlet of any other appliance;
8. Underneath a veranda, porch or deck, unless:
 - The veranda, porch or deck is fully open on a minimum of two sides beneath the floor and
 - The distance between the top of the vent termination and the underside of the veranda, porch or deck is greater than 1 foot (30.5 cm).

The vent system must terminate so that proper clearances are maintained as cited in national and/or local codes or suggested by the manufacturer:

1. Do not terminate the exhaust vent terminal over public area where condensate or vapor can cause nuisance or hazard.
2. For direct vent, the venting system shall terminate at least 1 foot (30.5 cm) below, 1 foot (30.5 cm) horizontally from or 1 foot (30.5 cm) above any door, window, or gravity air inlet into building.
3. For horizontal, the venting system shall terminate 4 feet (1.22 m) below, 4 feet (1.22 m) horizontally from or 1 foot (30.5 cm) above any door, window, or gravity air inlet into building.
4. The manufacturer also recommends the vent system terminations not be installed closer than 3 feet (1 m) from an inside corner of an L shaped structure.
5. The vent termination shall not be mounted directly above or within 3 feet (1 m) horizontally from an oil tank vent or gas meter to avoid potential freeze-up from condensation.
6. The vent shall terminate a minimum of 12 inches (30.5 cm) above expected snowfall level to prevent blockage of vent termination.

Vent pipes serving power vented appliances are classified by building codes as “vent connectors”. Required clearances from combustible materials must be provided in accordance with information in this manual under LOCATION OF WATER HEATER and CLEARANCES, national codes, and local codes.

Clearance to combustibles for all venting pipes and terminals	
<u>For installations in the US</u> 0” minimum	<u>For installations in the CANADA</u> Refer to vent pipe and terminal manufacturer’s installation instructions for clearances to combustibles
DO NOT place insulation or other materials in the required clearance spaces between the venting to combustible material unless otherwise specified.	

Horizontal Installation:

In a horizontal application, it is important that condensate not be allowed to buildup in the exhaust vent pipe. To prevent this from happening the pipe should be installed with a slight upward slope so the condensate will run back toward the water heater. The vent system should be supported every 5 feet (1.5 m) of vertical run and every 3 feet (1 m) of horizontal run of vent pipe length.

Stress levels in the pipe and fittings can be significantly increased by improper installation. If rigid pipe clamps are used to hold the pipe in place, or if the pipe cannot move freely through a wall penetration, the pipe may be directly stressed, or high thermal stresses may be formed when the pipe heats up and expands. Install accurately to minimize such stresses.

Follow the following procedure to vent through the wall:

1. Cut two 3 1/2 in. (8.9 cm) diameter holes (for 3" (7.6 cm) diameter pipe) or 4 1/2" (11.4 cm) diameter holes (for 4" (10.2 cm) diameter pipe) in the wall with the centerline hole distances at least 36" (91.4 cm) apart in the location where the exhaust vent and air intake terminals will exit the outside wall if vented on the same wall.
2. Use the proper PVC cement to secure the 90° exhaust vent and air intake terminals provided with the water heater to the plastic pipes. The distance between the back edge of the 90° exhaust vent terminal and the exterior wall (see Figure 12) must be 6 inches (12.7 cm) more for the exhaust vent terminal than the air intake terminal. Use the proper cement or sealant and assembly procedures to secure the vent connector joints between the terminal and the blower outlet. Provide support brackets for every 3 feet (.91 m) of horizontal vent.

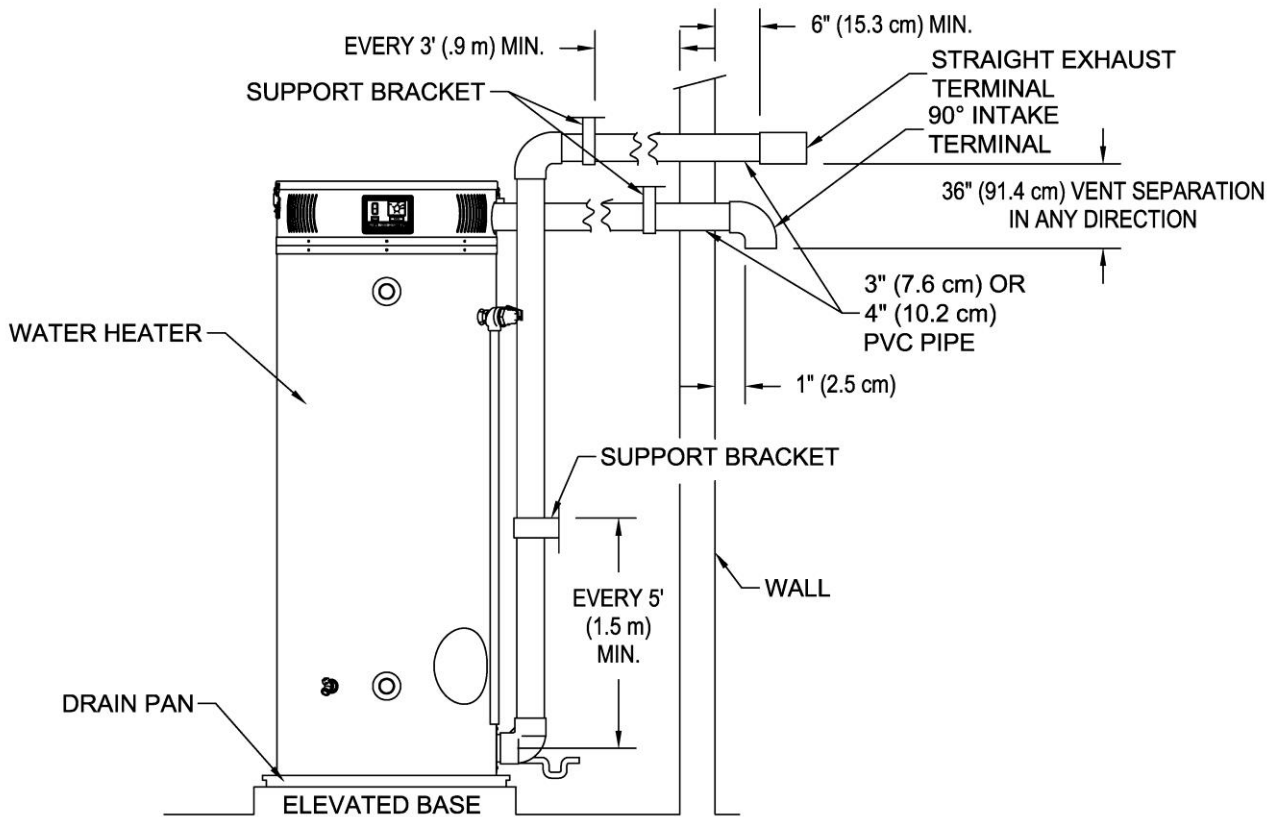

Figure 12. Typical Horizontal Direct Vent System

Vertical Installation:

Vertical venting system **must be** supported every 5 feet (1.5 m) of vertical run and every 3 feet (1 m) of horizontal run of vent pipe length.

Stress levels in the pipe and fittings can be significantly increased by improper installation. If rigid pipe clamps are used to hold the pipe in place, or if the pipe cannot move freely through a wall penetration, the pipe may be directly stressed, or high thermal stresses may be formed when the pipe heats up and expands. Install accordingly to minimize such stresses.

Follow the following procedure to vent through the roof:

1. Cut the necessary holes through the roof, ceiling, and/or wall (refer to preceding horizontal vent installation for proper vent diameters).
2. Install the exhaust vent and air intake vent pipes as shown in Figure 13 (also refer to preceding horizontal vent installation). Make sure that the installation meets national and/or local codes. Use the proper assembly procedures to secure the vent connector joints.

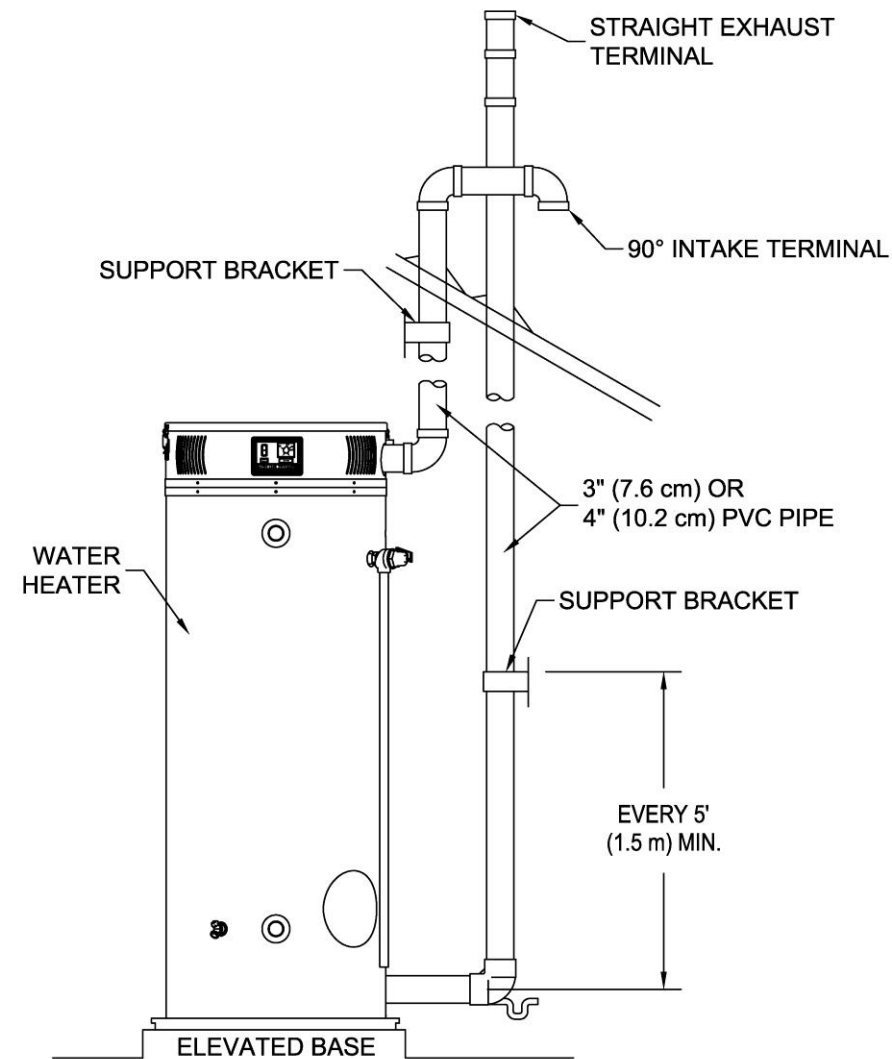

Figure 13. Typical Vertical Direct Vent System Installation

Through The Wall Venting With Low Ground Clearance:

When venting cannot exit through the wall at a height greater than or equal to 12 inches (30.5 cm) (and above expected snow level) from the ground, then the installation must be modified as shown below (see Figure 14).

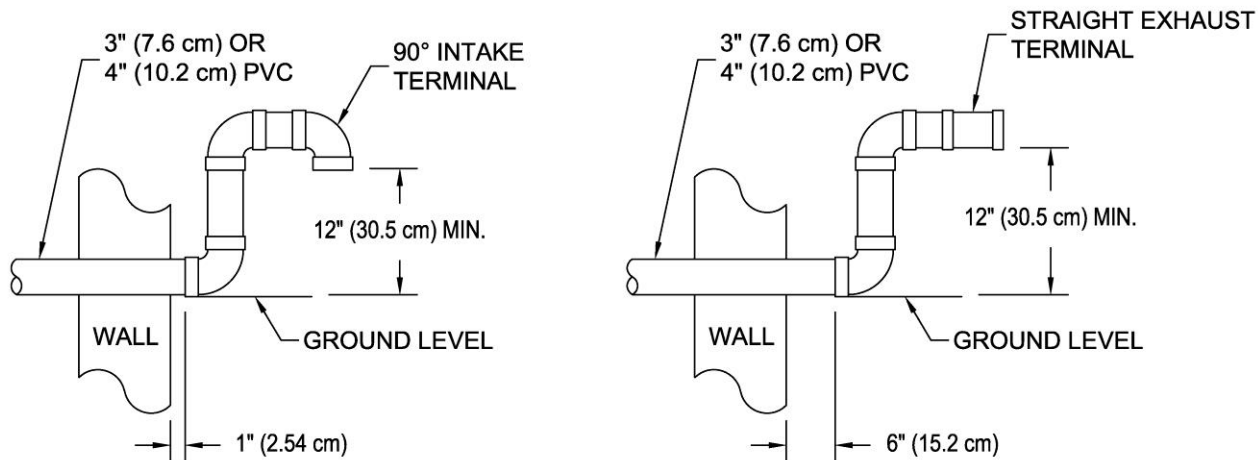

Figure 14. Vent Terminal (Low Ground Clearance)

Maximum Vent Length:

Direct Vent Maximum Vent Length

Storage Capacity (Liters)	Rated Input (Kilowatts)	Max Vent Length (meters) 3" (7.6 cm) Dia. venting	Max Vent Length (meters) 4" (10.2 cm) Dia. venting
227	36.6	36.6	51.8
227	43.9	30.5	45.7
227	58.6	24.4	39.6
379	43.9	36.6	51.8
379	58.6	30.5	45.7
379	73.3	24.4	39.6

Table 3

Determining required vent length:

1. Determine the total length of straight vent pipe (in meters) required for both the intake and the exhaust.
2. Add 1.5 meters of venting for every 90° elbow.
3. Add 76 cm of venting for every 45° elbow.
4. **Total vent length cannot exceed "Max Vent Length" in Table 3.**
5. **Air intake cannot exceed exhaust by more than 9.1 meters in any venting situation.**

NOTICE

Do not include the 3" (7.6 cm) exhaust elbow or vent terminals in determining maximum vent length.

POWER VENT INSTALLATION

Power venting is where the indoor air is used for combustion and the exhaust is vented to the outside. Venting may be installed horizontally through an outside wall or vertically through a roof through using either 3-inch (7.6 cm) or 4-inch (10.2 cm) diameter vent pipe. This water heater is supplied with a 3-inch (7.6 cm) screened intake and 3-inch (7.6 cm) exhaust 90° elbow referred to as the exhaust vent terminal and the air intake terminal.

POWER VENT TERMINAL LOCATION

Refer to the “Direct Vent Terminal Location” section previously mention to determine the proper exhaust vent location. Plan the vent system layout so that proper clearances are maintained from plumbing and wiring. Vent pipes serving power vented appliances are classified by building codes as “vent connectors”. Required clearances from combustible materials must be provided in accordance with information in this manual under LOCATION OF WATER HEATER and CLEARANCES, national codes, and local codes.

Clearance to combustibles for all venting pipes and terminals	
<u>For installations in the US</u> 0” minimum	<u>For installations in the CANADA</u> Refer to vent pipe and terminal manufacturer’s installation instructions for clearances to combustibles
DO NOT place insulation or other materials in the required clearance spaces between the venting to combustible material unless otherwise specified.	

Horizontal Installation:

In a horizontal application, it is important that condensate not be allowed to buildup in the exhaust vent pipe. To prevent this from happening, the pipe should be installed with a slight upward slope. The vent system should be supported every 5 feet (1.5 m) of vertical run and every 3 feet (1 m) of horizontal run of vent pipe length.

Stress levels in the pipe and fittings can be significantly increased by improper installation. If rigid pipe clamps are used to hold the pipe in place, or if the pipe cannot move freely through a wall penetration, the pipe may be directly stressed, or high thermal stresses may be formed when the pipe heats up and expands. Install accordingly to minimize such stresses.

Follow the following procedure to vent through the wall:

1. Cut the necessary hole through the wall (refer to preceding horizontal vent installation section for proper vent diameters).
2. Install the exhaust vent and air intake vent pipes as shown in Figure 16. Make sure that the installation meets national and/or local codes. The distance between the back edge of the exhaust vent terminal and the exterior wall (see Figure 15) must be 6 inches (13.0 cm). Use the proper assembly procedures to secure the vent connector joints.

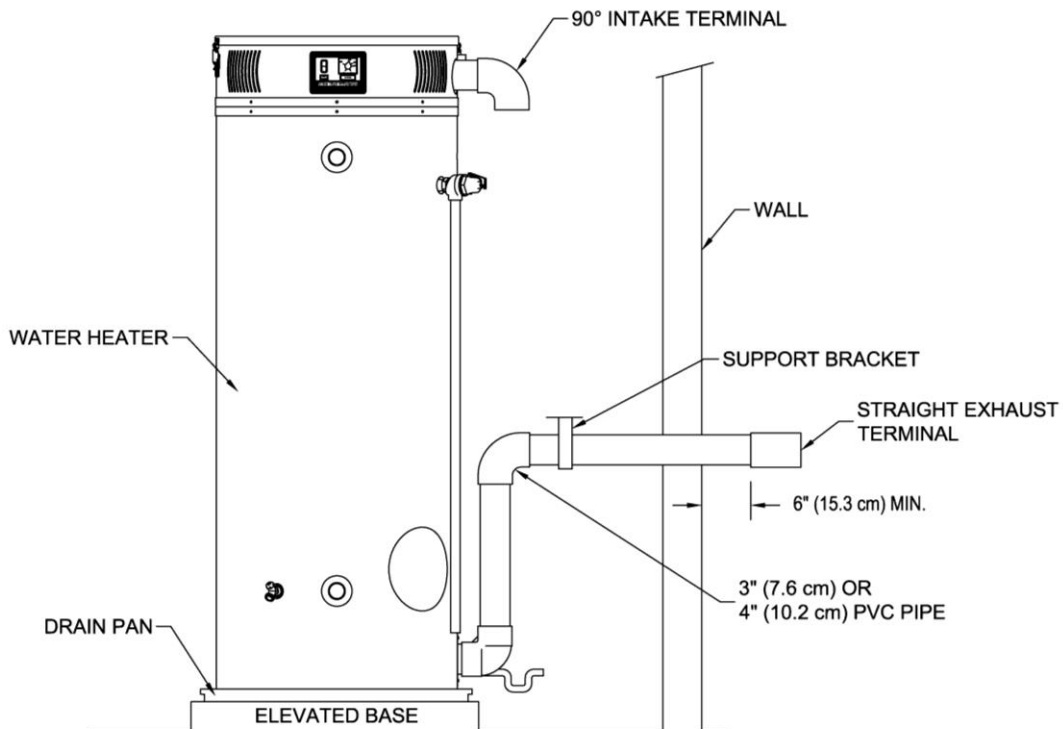

Figure 15. Typical Horizontal Power Vent System

Vertical Installation:

Vertical venting **must be** supported every 5 feet (1.5 meters) of vertical run and every 3 feet (1 meter) of horizontal run of vent pipe length.

Stress levels in the pipe and fittings can be significantly increased by improper installation. If rigid pipe clamps are used to hold the pipe in place, or if the pipe cannot move freely through a wall penetration, the pipe may be directly stressed, or high thermal stresses may be formed when the pipe heats up and expands. Install accordingly to minimize such stresses.

Follow the following procedure to vent through the roof:

1. Cut the necessary holes through the roof and ceiling (refer to the preceding venting sections, for proper vent diameters).
2. Install the exhaust vent and air intake plastic pipes as shown in Figure 16. Make sure that the installation meets national and/or local codes. Use the proper assembly procedures to secure the vent connector joints.

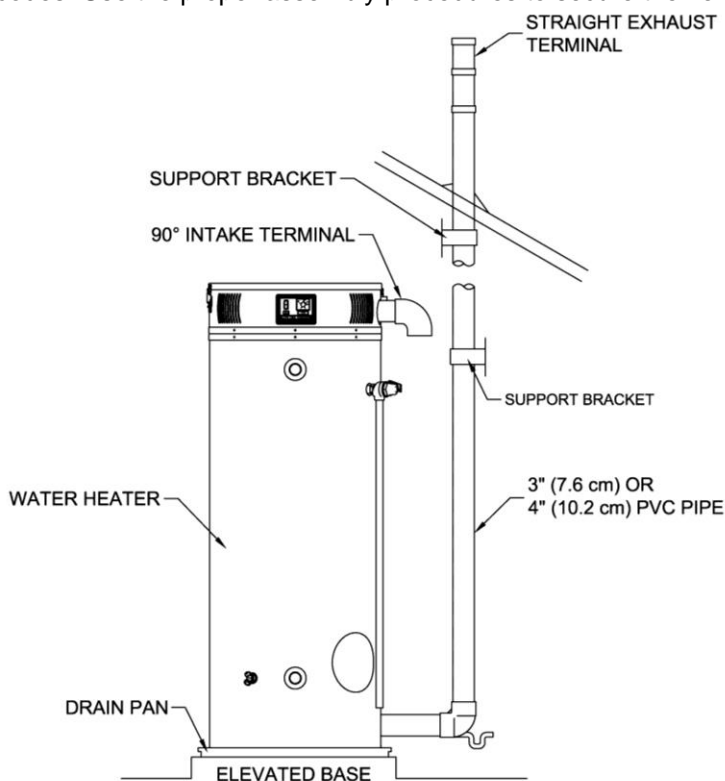

Figure 16. Typical Vertical Power Vent System Installation

Power Vent Maximum Vent Length

Storage Capacity (Liters)	Rated Input (Kilowatts)	Max Vent Length (meters)	
		3" (7.6 cm) Dia. venting	4" (10.2 cm) Dia. venting
227	36.6	36.6	51.8
227	43.9	30.5	45.7
227	58.6	24.4	39.6
379	43.9	36.6	51.8
379	58.6	30.5	45.7
379	73.3	24.4	39.6

Table 4

Determining required vent length:

1. Determine the total length of straight vent pipe (in meters) required.
2. Add 1.5 meters of venting for every 90° elbow.
3. Add 76 cm of venting for every 45° elbow.
4. **Total vent length cannot exceed "Max. Vent Length" in Table 4.**

NOTICE

Do not include the 3" (7.6 cm) exhaust elbow or vent terminals in determining maximum vent length.

MULTIPLE INTAKE/EXHAUST TERMINAL SEPARATION DISTANCES

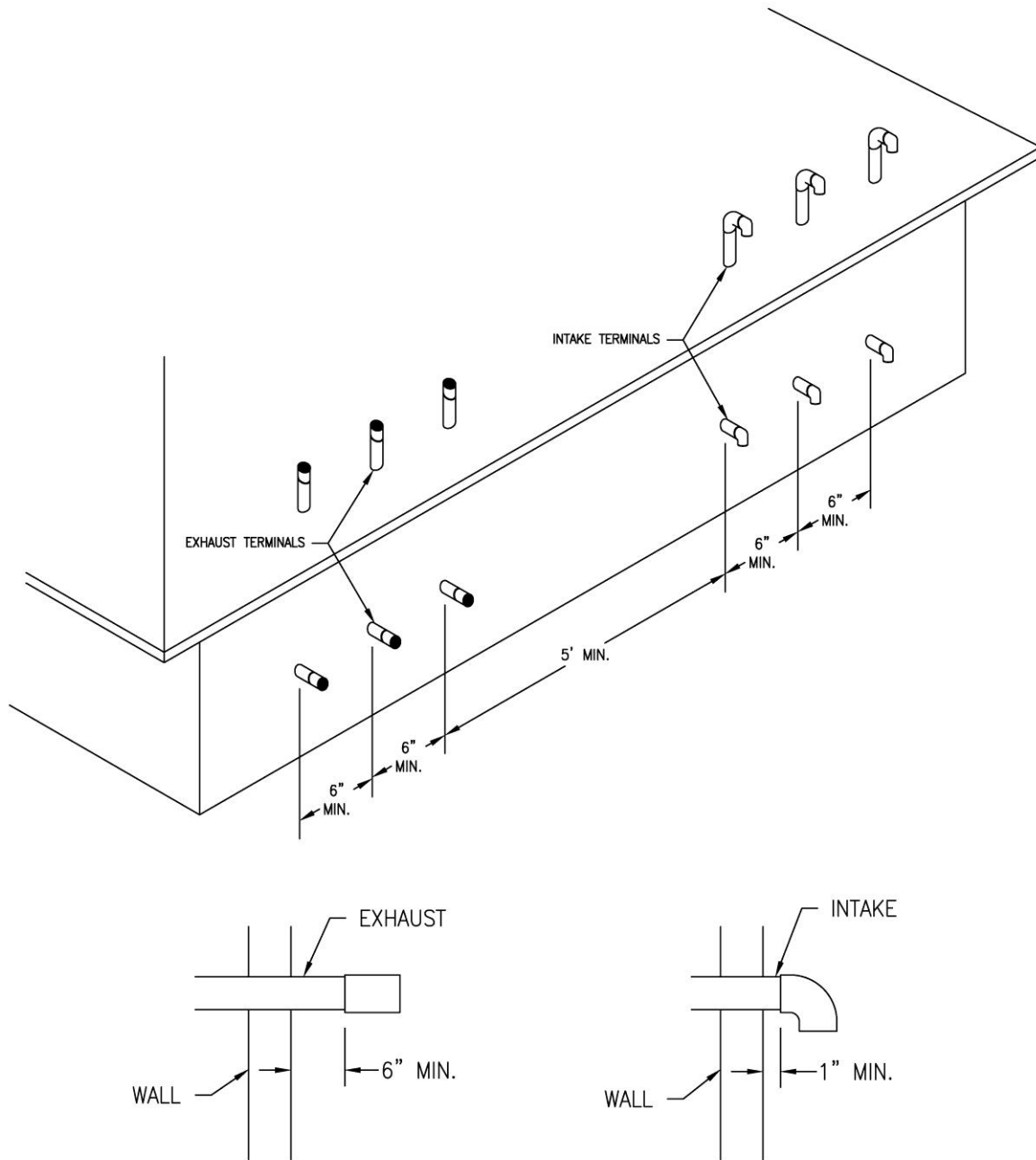

Note: When installing multiple intake/exhaust terminals on the same wall of a building, the nearest intake terminal must be at least 5 feet (1.5 m) from the nearest exhaust terminal. Spacing requirements are the same for roof installation.

COAXIAL VENTING INSTALLATION PROCEDURE (OPTIONAL COMPONENTS)

WARNING

Improper installation, adjustment, service, or maintenance can cause property damage, personal injury, or death. Consult a qualified installer, service agency, or the gas supplier for information or assistance.

This kit must be used only for terminating this water heater. Do not use this termination kit for any other appliance. Using this kit on other appliances and/or water heaters can result in property damage, personal injury, or death.

DO NOT operate this water heater until the installation and assembly of this kit is complete and the piping completed. Failure to complete installation before operation can result in property damage, personal injury, or death.

Before beginning any installation, be sure the main electrical disconnect switch is in the OFF position. Electrical shock can cause personal injury or death.

DO NOT operate this water heater with the rain cap removed or recirculation of combustion products may occur. Water may also collect inside larger combustion-air pipe and flow to the burner assembly. Failure to follow this warning could result in product damage, or improper operation, personal injury or death.

CAUTION

DO NOT use field-supplied couplings to extend pipes. Airflow restriction will occur and the water heater pressure switches may cause intermittent problems.

Vertical Installation (Recommended)

1. Become familiar with coaxial vent kit part no. 239-44069-01.

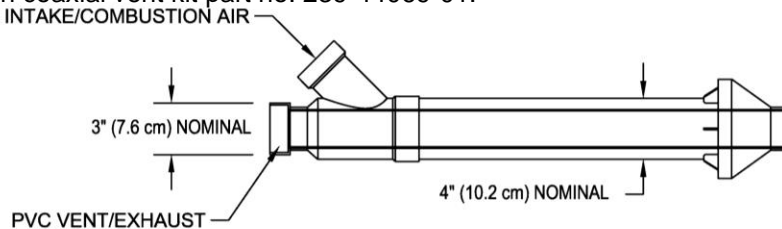

Figure 17. Dimensional Layout of Concentric Vent Kit

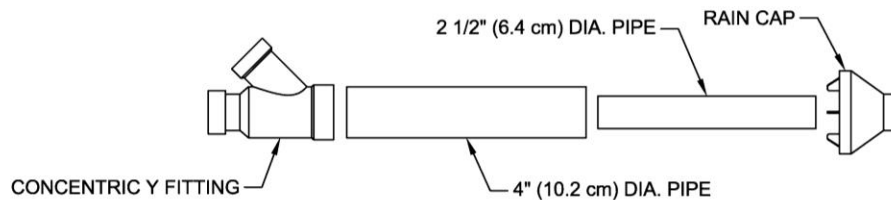

Figure 18. Concentric Vent Kit Part Identification

2. Determine the best location for the termination kit.
3. Cut the recommended 5" diameter hole.
4. Partially assemble vent kit by performing the following:
 - a. Cement concentric Y fitting to larger diameter pipe. (See Figure 18).
 - b. Cement rain cap to smaller diameter pipe. (See Figure 19).

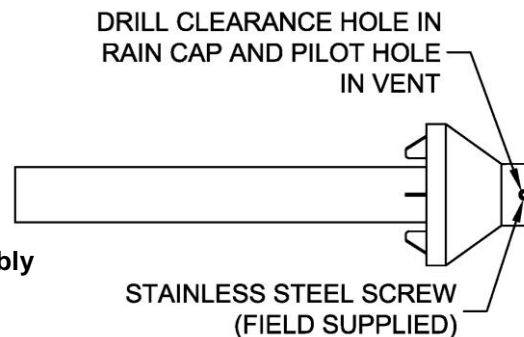

Figure 19. Rain Cap to Small Vent Pipe Assembly

5. Install concentric Y fitting and pipe assembly through the structure's hole and field-supplied roof boot/flashing. Do not allow insulation or other materials to accumulate inside pipe assembly when installing through the hole.
6. Secure assembly to roof structure as shown in Figure 20 using field-supplied metal strapping or equivalent support material.

NOTICE

Ensure termination height is above the roof surface or anticipated snow level. Figure 20.

If assembly is too short to meet height requirements, the 2-pipe supplied in the kit may be replaced by using the same diameter pipe. DO NOT extend the overall dimension by more than 60 in. (see Fig. 16).

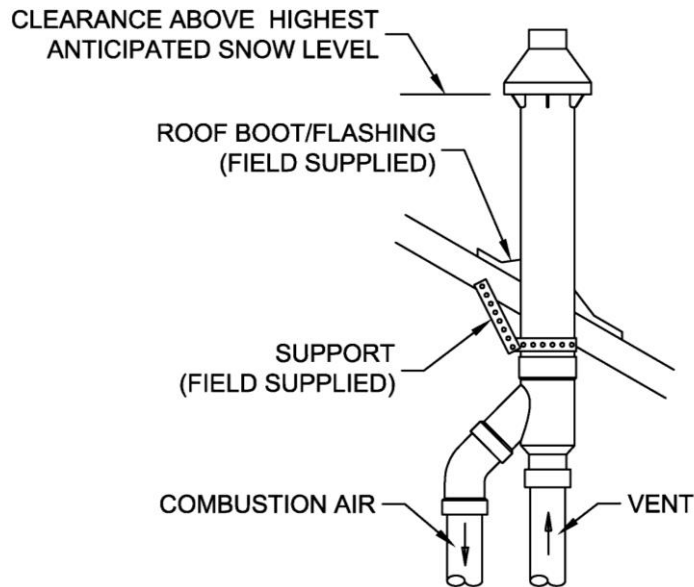

Figure 20. Concentric Vent Roof Top Attachment

7. Install rain cap and small diameter pipe assembly in roof penetration assembly. Ensure small diameter pipe is cemented and bottomed in Y concentric fitting.
8. Cement heater combustion-air and vent pipes to concentric y fitting assembly (Figure 18). See Figure 20 for proper pipe attachment.
9. Operate heater through one cycle to ensure combustion-air and vent pipes are properly connected to concentric vent termination connections.

Horizontal Installation:

1. Become familiar with coaxial vent kit part no. 239-44069-01. As shown in Figure 21.
2. Determine the best location for the termination kit.

NOTICE

Position termination where vent vapors will not damage plants/shrubs or air conditioning equipment.

Position termination where vent vapors will not be adversely affected by wind condition.

Position termination where it will not be damaged or be subjected to foreign objects.

Position termination where vapors will not be objectionable.

3. Cut the recommended 5" diameter hole.
4. Partially assemble vent kit.
 - a. Cement Y concentric fitting to larger diameter kit pipe. (See Figure 18).
 - b. Cement rain cap to smaller diameter kit pipe. (See Figure 19).
5. Install concentric Y fitting and pipe assembly through the structure's hole and field-supplied roof boot/flashing. Do not allow insulation or other materials to accumulate inside pipe assembly when installing through the hole.

6. Install rain cap and small diameter pipe assembly in concentric Y fitting and large pipe assembly. Ensure small diameter pipe is cemented and bottomed in concentric Y fitting.
7. Secure assembly to structure as shown in Figure 21. Ensure clearances as shown in Figure 21.

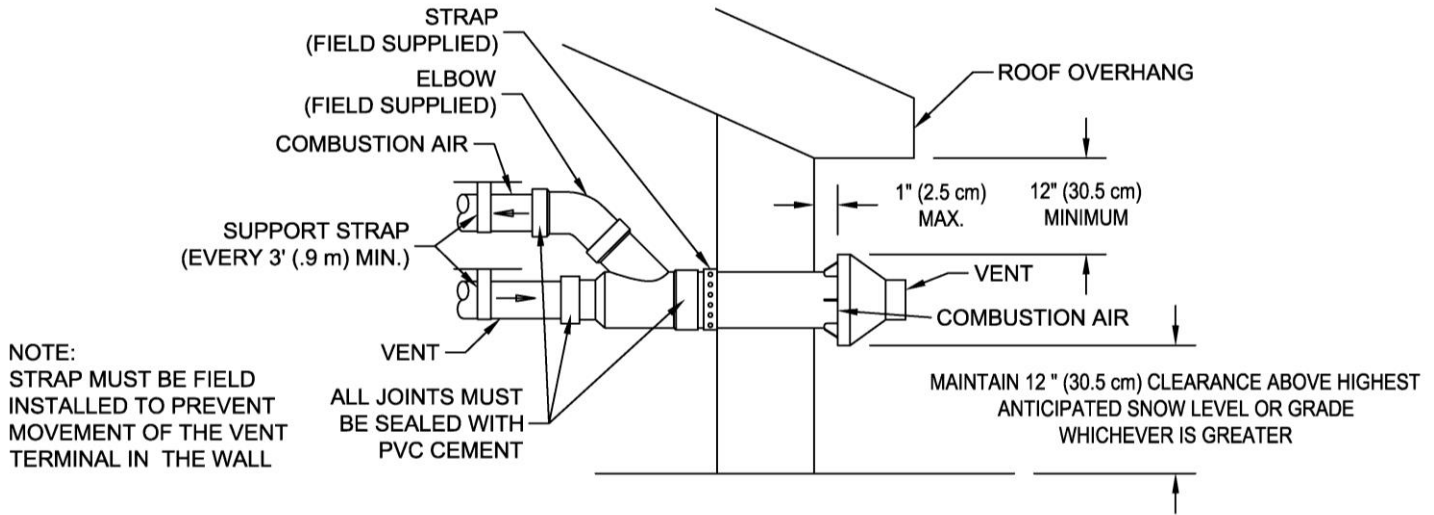

Figure 21. Concentric Vent Side Wall Attachment

8. Cement heater combustion-air and vent pipes to concentric Y fitting termination assembly. See Figure 22 for proper pipe attachment.
9. Operate heater through one cycle to ensure combustion-air and vent pipes are properly connected to concentric vent termination connections.

VENT PIPE PREPARATION

⚠ WARNING

DO NOT attempt to start this water heater until vent pipe solvent fumes (if used) completely clear from the room and inside the vent piping.

INITIAL PREPARATION

1. Make sure the solvent cement you are planning to use is designed for the specific application you are attempting.
2. Know the physical and chemical characteristics and limitations of the PVC, ABS or CPVC piping materials that you are about to use.
3. Know the reputation of your pipe and cement manufacturer and their products.
4. Know your own qualifications or those of your contractor. The solvent welding technique of joining PVC, ABS or CPVC pipe is a specialized skill just as any other pipe fitting technique.
5. Closely supervise the installation and inspect the finished job before start-up.
6. Contact the manufacturer, supplier, or competent consulting agency if you have any questions about the application or installation of PVC, ABS or CPVC pipe.
7. Take the time and effort to do a professional job. Shortcuts will only cause you problems and delays in start-up. The majority of failures in these systems are the result of shortcuts and/or improper joining techniques.

SELECTION OF MATERIALS

PRIMER – It is recommended that Tetrahydrofuran (THF) be used to prepare the surfaces of pipe and fittings for solvent welding. Do not use water, rags, gasoline or any other substitutes for cleaning PVC, ABS or CPVC surfaces. A chemical cleaner such as MEK may be used.

CEMENT – The cement should be a bodied cement of approximately 500 to 1600 centipoises viscosity containing 10-20% (by weight) virgin PVC material solvated with tetrahydrofuran (THF). Small quantities of dimethylformamide (DMF) may be included to act as a retarding agent to extend curing time. Select the proper cement; Schedule 40 cement should be used for Schedule 40 pipe. Never use all-purpose cements, commercial glues and adhesives or ABS cement to join PVC or CPVC pipe and fittings.

SAFETY PRECAUTION: PRIMERS AND CEMENTS ARE EXTREMELY FLAMMABLE AND MUST NOT BE STORED OR USED NEAR HEAT OR OPEN FLAME. ALSO, USE ONLY IN A WELL-VENTILATED AREA.

SECTION VII: GAS CONNECTIONS

WARNING

Connect this water heater only to the type of gas as shown on the rating plate. Use clean black iron pipe or equivalent material approved by local codes and ordinances. (Dirt and scale from the pipe can enter the gas valve and cause it to malfunction). The inlet gas line must have at least a 3-inch (7.62 cm) drip leg (sediment trap) installed as close to the water heater's gas valve as possible. A ground joint union must be installed in the gas supply line, as close to the water heater as possible, to permit servicing of the water heater. Compounds used on the threaded joints of the gas piping must be resistant to the action of liquefied petroleum gases/propane gas. **DO NOT** apply pipe dope to the gas valve inlet and make certain that no pipe dope has become lodged in the inlet screen of the gas valve. Extreme care must be taken to ensure no pipe dope enters the gas valve and to avoid excessive torque when tightening the gas supply line to the gas valve. Excessive torque may result in cracking of the gas valve housing. The suggested maximum torque is 31.5 foot lbs. (4.4 kg-m). The manufacturer of this water heater will not be liable for any damage or injury caused as a result of a cracked gas inlet as a result of excessive torque.

This water heater and its gas connection must be leak tested before placing the water heater in operation. Check for gas leaks with a soap and water solution and a brush or a commercial leak detector fluid.

NEVER USE A MATCH OR OPEN FLAME FOR TESTING!

The water heater is not intended for operation at higher than 14.0-inch water column (34.87 mbar) supply gas pressure. Higher gas supply pressures require supplemental reducing service regulation. Exposure to higher gas supply pressure may cause damage to the gas controls, which could result in fire or explosion. If overpressure has occurred such as through improper testing of gas lines or emergency malfunction of the supply system, the gas valve must be checked for safe operation. Make sure that the outside vents on the supply regulators and the safety vent valves are protected against blockage. These are parts of the gas supply system, not the water heater.

CAUTION

The water heater and individual shutoff valve must be disconnected from the gas supply piping system during any pressure testing of the system at test pressures in excess of 1/2 psi (3.5 kPa). The water heater must be isolated from the gas supply piping system by closing its manual shutoff valve during any pressure testing of the gas supply system at test pressures equal to or less than 1/2 psi (3.5 kPa). The supply line must be capped when not connected to the water heater.

If copper supply lines are used, they must be internally tinned and certified for gas service.

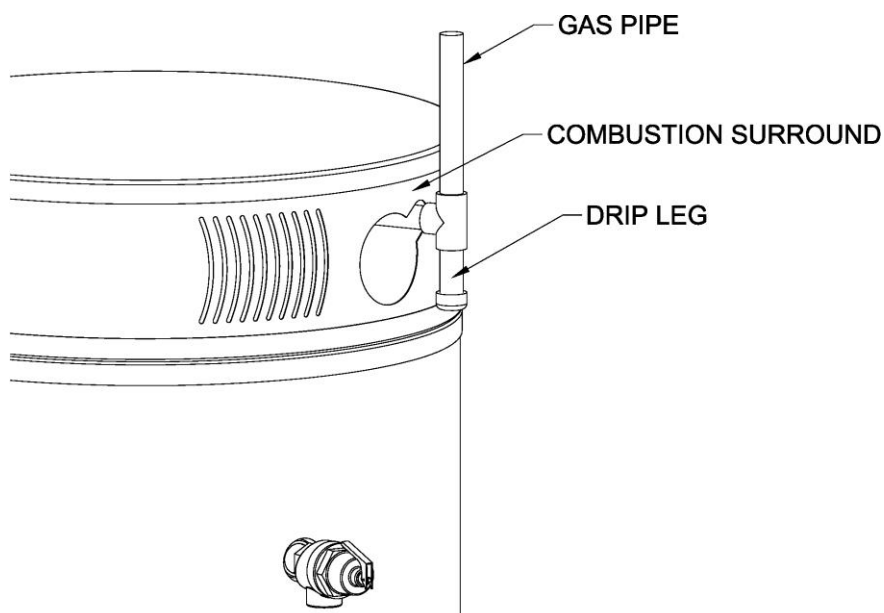

Figure 22. Drip Leg

The gas supply lines must meet all requirements of national and/or local codes.

GAS METER SIZE – NATURAL GASES ONLY

Be sure that the gas meter has sufficient capacity to supply the full rated gas input of the water heater as well as the requirements of all other gas fired equipment supplied by the meter. If the gas meter is too small, ask the gas company to install a larger meter having adequate capacity.

GAS PRESSURE REGULATION

Main line gas pressure to the water heater should be between a maximum 34.87 mbar and a minimum supply pressure as shown on the rating plate. The inlet gas pressure must not exceed the maximum value.

BEFORE PLACING THE WATER HEATER IN OPERATION, CHECK FOR GAS LEAKAGE. USE SOAP AND WATER SOLUTION OR OTHER MATERIAL ACCEPTABLE FOR THE PURPOSE OF LOCATING GAS LEAKS.



WARNING

DO NOT USE MATCHES, CANDLES, FLAME OR OTHER SOURCES OF IGNITION FOR THIS PURPOSE.

SECTION VIII: ELECTRICAL CONNECTIONS



WARNING

Turn off or disconnect the electrical power supply to the water heater before servicing. Label all wires prior to disconnection when servicing controls. Wiring errors can cause improper and dangerous operation. Verify proper operation after servicing.

All electrical wiring must be installed and grounded in accordance with national and/or local codes, or in the absence of local codes.

The water heater must be wired to a 230 VAC, 50 Hz, 15A power supply. The water heater must be wired on a separate circuit and breaker. If a flexible line cord and plug is permitted by local code, then provide a receptacle within reach of the line cord provided on the control box. Do not plug the line cord into a receptacle that can have the power supply interrupted by a switch that is used to control lights or another appliance. **(Refer to national and/or local codes for installation)**

If wiring in conduit is required, remove the line cord and strain relief bushing in the control panel and install an electrical conduit connector. Connect the hot, neutral, and ground leads to the terminal block using quick connect terminals. Refer to the wiring diagram for the correct terminal locations for each wire lead.



CAUTION

Do not energize the electric circuit before the water heater tank is filled with water.

This controller is Polarity sensitive. If the Hot and Neutral Supply voltage is reversed, the controller will not sense flame and the water heater will not operate. Verify polarity before connecting the water heater.

WIRING DIAGRAM

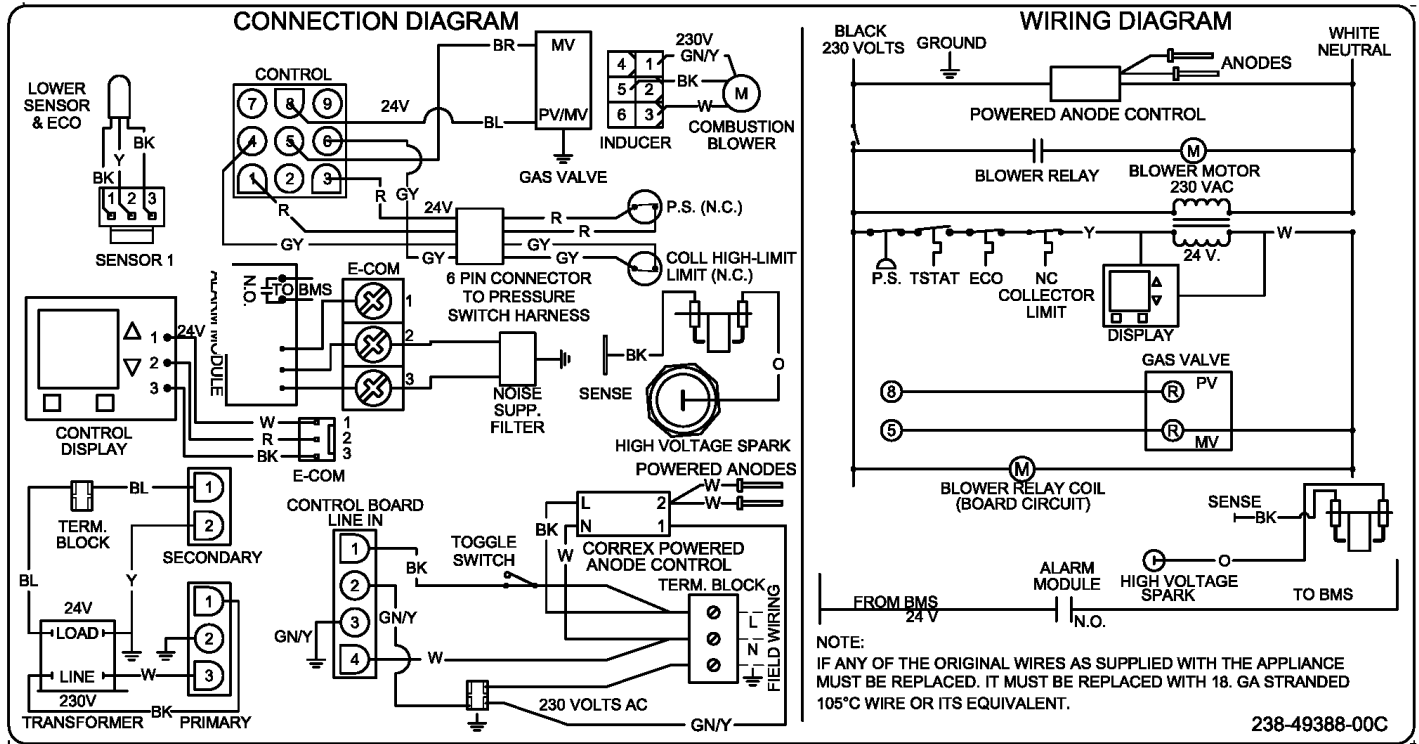

Figure 23a. Wiring Diagram

SECTION IX: COMMISSIONING

Air/Gas Mixture Adjustment

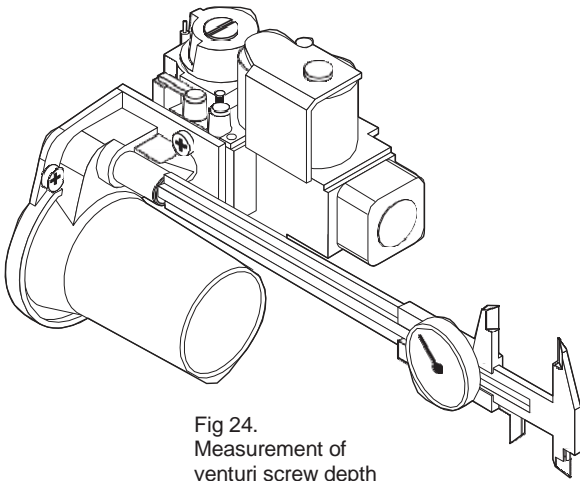

Fig. 24.
Measurement of
venturi screw depth

The water heater gas/air mixture is adjusted at the factory for the proper mixture for optimum combustion and ignition for the type of gas listed on the rating label. The water heater should operate properly without requiring adjustment with the gas type shown on the rating label.

The following is a guide for the correct mixture adjustment settings in case the gas content is different from the rating label or ignition is not satisfactory. A combustion analyzer is necessary for making gas/air mixture adjustments to determine the correct setting.

The water heater cannot be converted from natural to L.P. gas or L.P. gas to natural gas. Using L.P. gas on a water heater set up for natural gas will result in rough ignitions and dangerous levels of carbon monoxide.

Do not attempt to adjust the venturi screws without a properly calibrated CO²/CO combustion analyzer. Making the mixture richer without an analyzer to monitor the adjustments can result in dangerous levels of carbon monoxide.

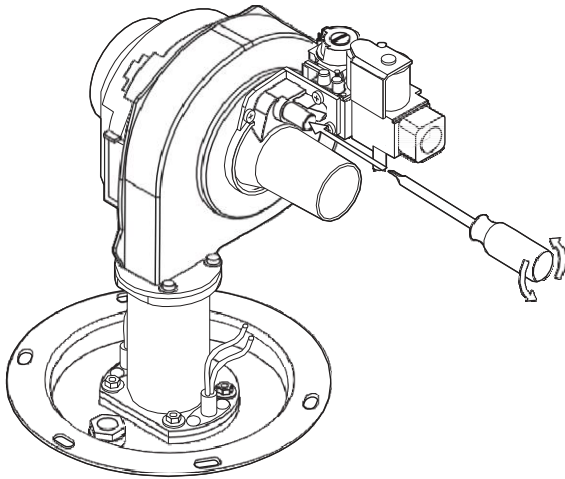

Fig. 25
Adjust the gas mixture by turning the venturi screw.

G20 (Natural gas, mostly methane) family

The CO₂ range should be set as detailed in the table below.

The CO content should be less than 50ppm.

If the CO₂ content is above the correct percentage, turn the venturi screw (see fig. 25), clockwise half a turn and recheck combustion. Repeat, if necessary, until the correct reading is achieved. Turn the venturi screw counterclockwise if the CO₂ reading is less than the stated figure or if the ignitions are not smooth.

CO₂ Percentage

MODEL REFERENCE	INPUT RATINGS (KW/HR.)	COMBUSTION (CO ₂ /CO)	FLUE GAS VOLUME – CUBIC METERS/HR.	VENT TEMPERATURE - °C
60T125E3N2	36.6	8.7-8.8% / 0 ppm	40	50-60
60T150E3N2	43.9	9.1-9.2% / 0 ppm	49	50-60
60T199E3N2	58.6	9.1-9.2% / 0 ppm	63	50-60
100T150E3N2	43.9	9.2-9.3% / 0 ppm	49	50-50
100T199E3N2	58.6	9.2-9.3% / 0 ppm	63	50-55
100T250E3N2	93.2	8.8-9.2% / 0 ppm	75	50-60
100T300E3N2	85	9.3-9.4% / 0 ppm	86	50-60

SECTION X: OPERATING INSTRUCTIONS



WARNING

Water heaters are heat-producing appliances. To avoid damage or injury there must be no materials stored against the water heater or direct vent system, and proper care must be taken to avoid unnecessary contact (especially by children) with the water heater and direct vent system. UNDER NO CIRCUMSTANCES SHOULD FLAMMABLE MATERIALS, SUCH AS GASOLINE OR PAINT THINNER BE USED OR STORED IN THE VICINITY OF THIS WATER HEATER OR IN ANY LOCATION FROM WHICH FUMES COULD REACH THE WATER HEATER.

Installation or service of this water heater requires ability equivalent to that of a licensed tradesman in the field involved. Plumbing, air supply, venting, gas supply and electrical work are required.

Light the unit in accordance with the operating instructions label attached to the water heater.

Under no circumstances should the input rate exceed the input rate shown on the water heater rating plate. Over firing could result in damage or sooting of the water heater.

If the unit is exposed to the following, do not operate water heater until all corrective steps have been made by a factory authorized independent service contractor or qualified service professional.

1. Flooding to or above the level of the burner or controls
2. External firing
3. Damage
4. Firing without water
5. Sooting

NEVER OPERATE THE WATER HEATER WITHOUT FIRST BEING CERTAIN IT IS FILLED WITH WATER AND A TEMPERATURE AND PRESSURE RELIEF VALVE IS INSTALLED IN THE RELIEF VALVE OPENING OF THE WATER HEATER.

GENERAL INSTRUCTIONS

TO FILL THE WATER HEATER

1. Close the water heater drain valve by turning the knob or valve stem clockwise. If alternative water connections are provided but not used, make certain they are plugged (i.e. rear connections).
2. Open the cold-water supply shut-off valve.
3. Open several hot water faucets to allow air to escape from the system.
4. When a steady stream of water flows from the faucets, the water heater is filled. Close the faucets and check for water leaks at the water heater drain valve, combination temperature and pressure relief valve and the hot and cold-water connections.

SEQUENCE OF OPERATION

1. Thermostat starts with heating cycle
2. Blower ON
3. Blower pre-purge
4. Spark rod sparks to the burner and gas valve opens – burner ignition
5. Main burner ON
6. Flame signal confirmed
7. Thermostat satisfied
8. Gas valve closes - Main burner OFF
9. Blower post-purge

TEMPERATURE ADJUSTMENT

Table 5. Approximate Time/Temperature Scald Chart.

APPROXIMATE TIME/TEMPERATURE RELATIONSHIPS IN SCALDS	
120°F (49°C)	More than 5 minutes
125°F (52°C)	1½ to 2 minutes
130°F (54°C)	About 30 seconds
135°F (57°C)	About 10 seconds
140°F (60°C)	Less than 5 seconds
145°F (63°C)	Less than 3 seconds
150°F (66°C)	About 1½ seconds
155°F (68°C)	About 1 second

LIGHTING AND SHUT-DOWN INSTRUCTIONS

LIGHTING INSTRUCTIONS

1. Set the thermostat to lowest setting.
2. Turn off all electrical power to the appliance.
3. Turn off the main power switch.
4. Wait five (5) minutes to clear out any gas.
5. Turn on the main power switch.
6. Set the thermostat to desired setting.
7. The main burners will light after a short period of time.

MAIN POWER SWITCH

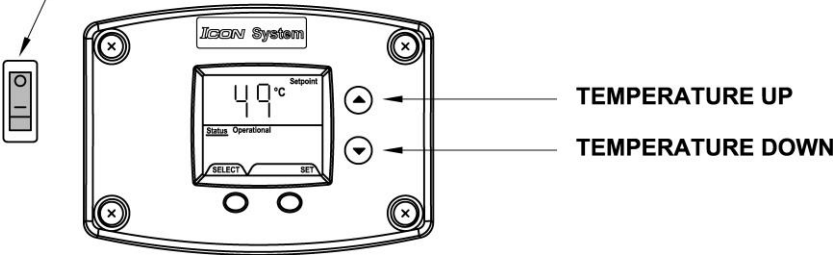

TEMPERATURE UP

TEMPERATURE DOWN

TO TURN OFF GAS TO APPLIANCE

1. Set the thermostat to lowest setting.
2. Turn off the main power switch.
3. The water heater should only be turned off for long periods (e.g. holidays) or in emergency. Otherwise, the water heater should be left to operate under thermostatic control.

Figure 24. Lighting Instruction Label.



CAUTION

This water heater, when set at a lower temperature setting, is not capable of producing hot water of sufficient temperature for sanitizing purposes.

This water heater is equipped with an energy cut out device to prevent overheating. Should overheating occur or the gas supply fails to shut off, turn off the control panel power switch to the appliance and call a qualified service agency.

NOTICE

The lower the temperature setting, the greater the energy efficiency, both to heat the water and to maintain the storage temperature during standby periods. Lower water temperatures also extend tank life. Remember, no water heating system will provide exact temperatures at all times. Allow a few days of operation at this setting to determine the correct temperature setting consistent with the requirements for the installation.

The water heater temperature setting is adjusted by using the control display mounted to control surround jacket of the water heater. The water heater thermostat is set at the lowest setpoint of 70°F (21°C) when shipped from the factory. The control display shows the temperature setpoint in degrees Fahrenheit (°F) or degrees Celsius (°C), and the status of the water heater ("Idle" or "Heating"). If the water heater is functioning normally, the display will also show "Operational".

For energy efficient operation of your water heater, the suggested initial temperature setting is 120°F (49°C). During the winter season, or any cold period, you may desire a higher temperature setting to adjust for the colder incoming water. This adjustment, however, may cause additional condensation to form on the cooler tank surface. This does not mean the tank is leaking. During summer months, the warmer incoming water temperatures will benefit the performance of your water heater and reduce the amount of condensation developed.

Condensation does not mean your tank is leaking. Most of reported tank leaks on installation are proven to be condensation. To avoid unnecessary inconvenience and expense, make sure the tank is leaking before calling an independent servicing contractor or qualified service professional.

If the water heater is to remain idle for 30 days or more or is subjected to freezing temperatures while shut off, the water heater and piping should be fully drained and the drain valve should be left fully open. Refer to the "General Operation" section of this Installation and Operation Manual for the procedure on draining the water heater.

! DANGER

Hotter water increases the risk of scald injury. Scalding may occur within 5 seconds at a temperature setting of 140°F (60°C). To protect against hot water injury, install an ASSE approved mixing valve in the water system. This valve will reduce point of discharge temperature by mixing cold and hot water in branch water lines. A licensed plumbing professional or local plumbing authority should be consulted.

! WARNING

If the water heater display does not show "Operational" in the "Status" indicator, there may be an operating malfunction with the water heater. If this is the case, a numeric code will be displayed. Refer to the label next to the display for the definition of the error code and call your plumbing professional or service agent to service the water heater. Do not try to reset the water heater without having a qualified service person to diagnose and correct the problem. If the display is blank or does not show an error code, make sure there is power to the water heater.

Setting the water temperature to the maximum set point can result in scalding hot water delivered to the faucets. It is highly recommended that the maximum setpoint be adjusted to the lowest temperature possible for the needs of the installation. See following section to change the maximum setpoint limit (max setpoint). Make sure the water heater control display is not in a public area that can result in the temperature settings being improperly adjusted. See previous warning on scalds and an ASSE approved mixing valve.

NOTICE

When the maximum setpoint is reached, the display will show "Max Setpoint" without the setpoint value. The maximum setting is equal to approximately 180°F (82°C).
The default temperature setpoint from the factory is 70°F (21°C).

Water Heater Display and Control Buttons

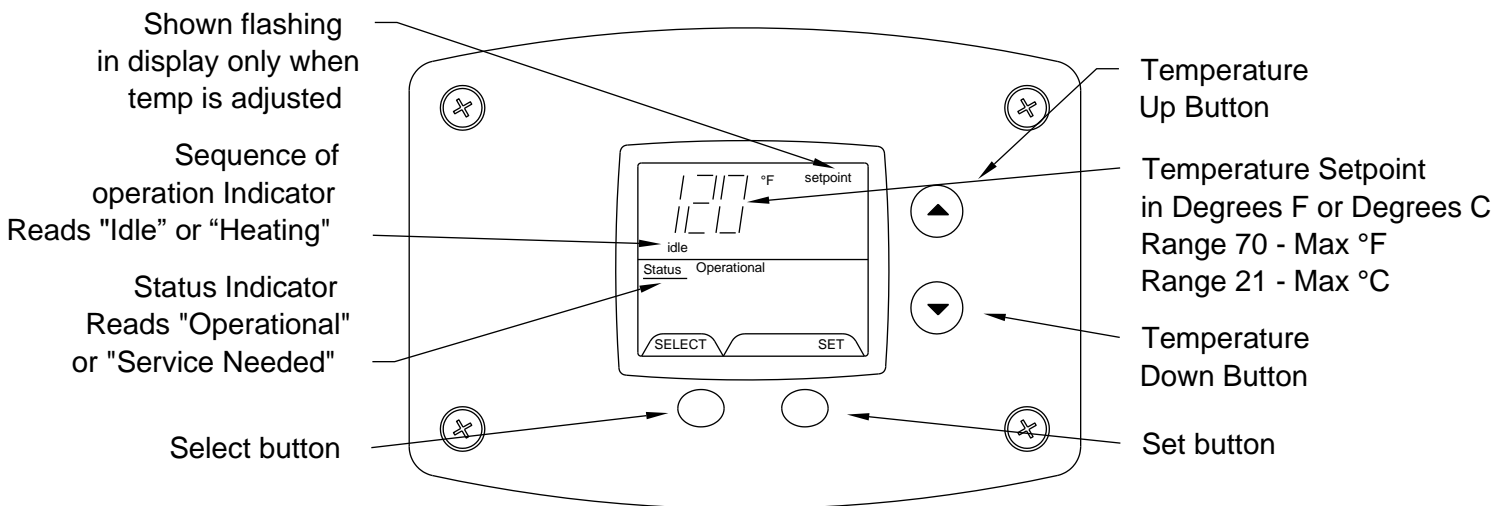

To Increase Setpoint Temperature

Step 1: Depress and hold "Temperature Up" button until desired setpoint temperature appears in the display.

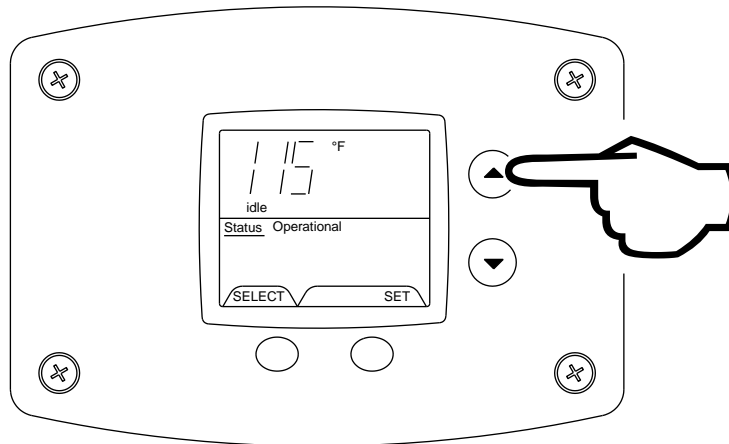

Step 2: "Setpoint" indicator begins flashing in the display after pressing "Temperature Up" button.

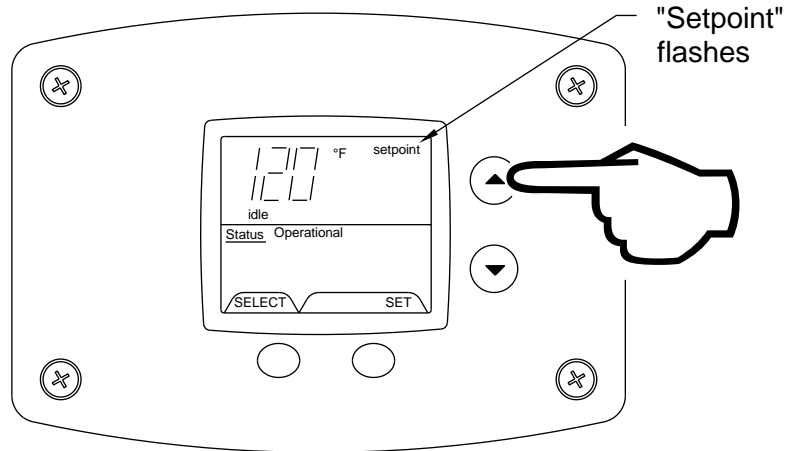

Step 3: Press "SET" button for new setting to take effect immediately. "Setpoint" will stop flashing. If the "SET" button is not pressed, the new temperature setting will take effect in approximately 10 seconds.

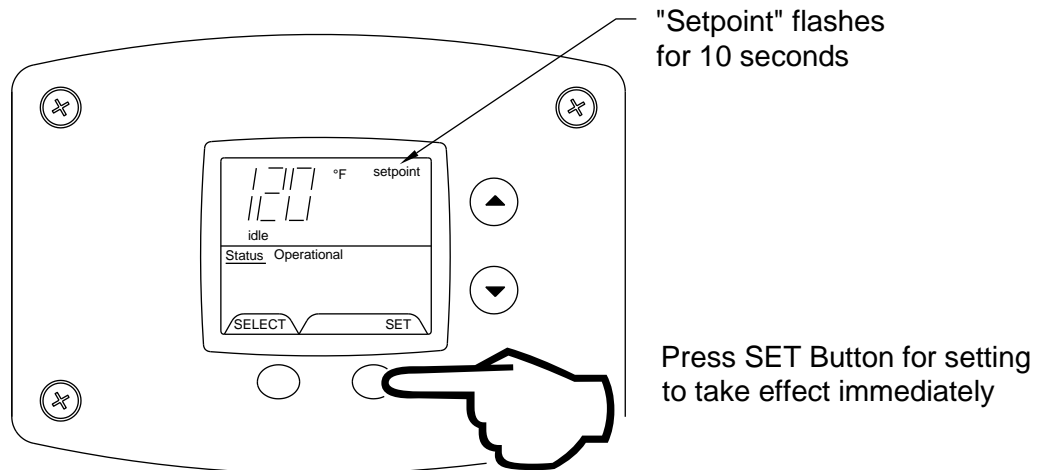

To Decrease Setpoint Temperature

Step 1: Depress and hold "Temperature Down" button until desired setpoint temperature appears in the display.

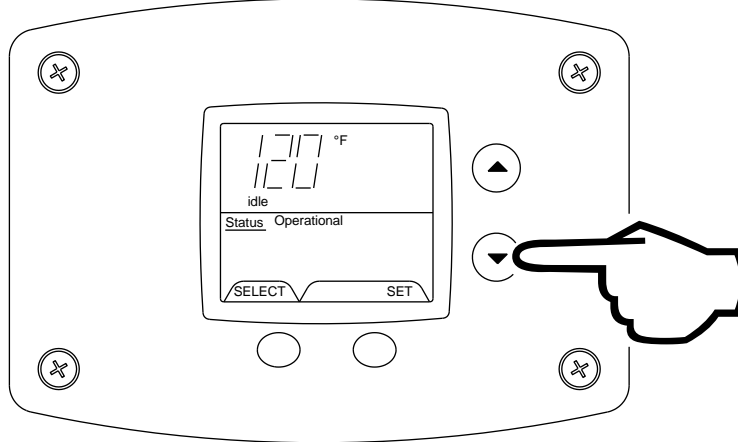

Step 2: "Setpoint" indicator begins flashing in the display after pressing "Temperature Down" button.

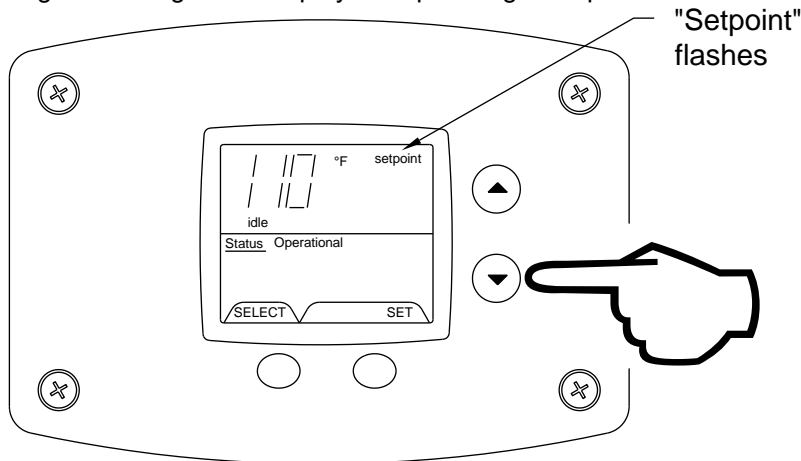

Step 3: Press "SET" button for new setting to take effect immediately. The setpoint will stop flashing. If the "SET" button is not pressed, the new temperature setting will take effect in approximately 10 seconds.

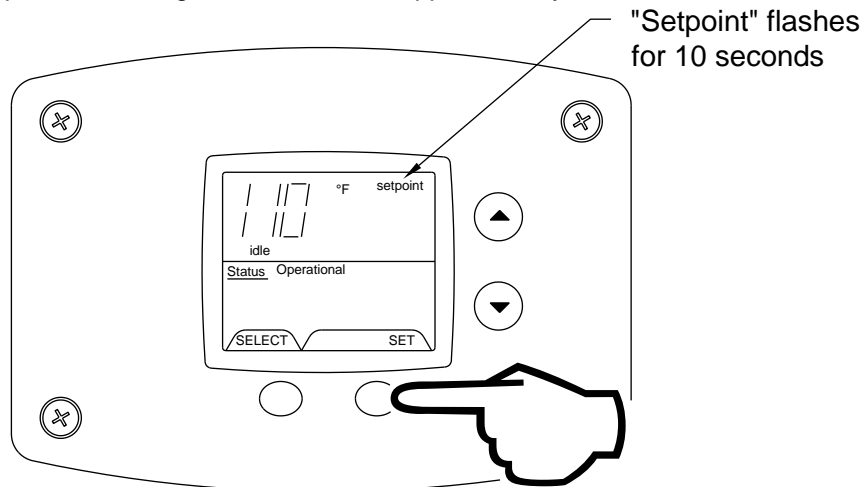

Press SET for setting to take effect immediately

To Change Temperature Format in Display from °F to °C or °C to °F:

Step 1: Press "SELECT" button until °F/°C is displayed.

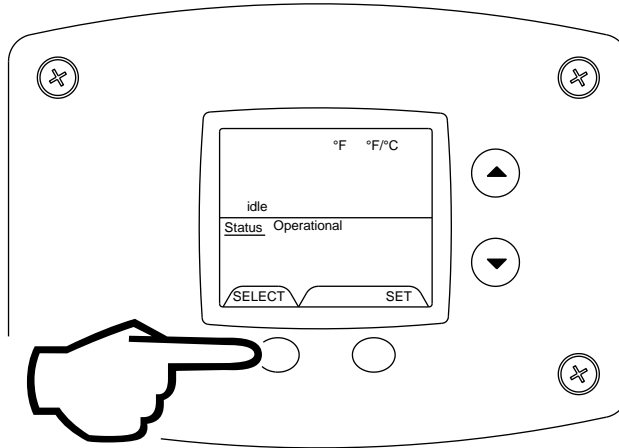

Press select

Step 2: Press "SET" button to change temperature format. Symbol °F/°C will flash.

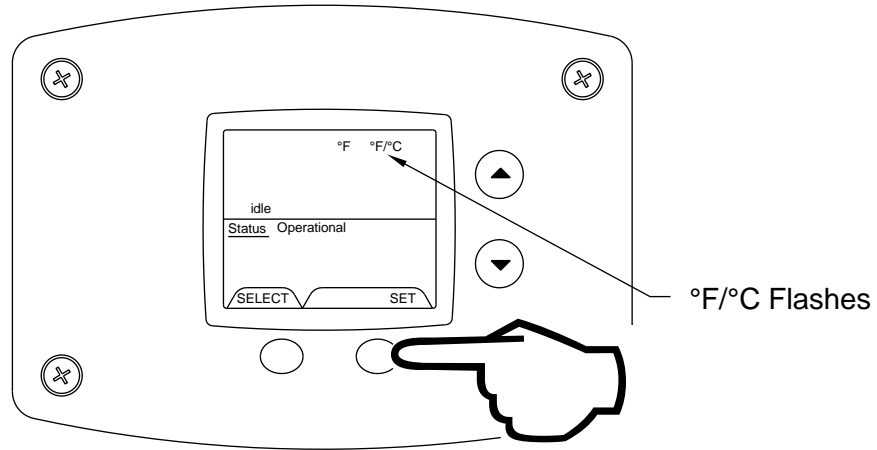

Step 3a: Press "Temperature Up" button to change temperature format to °C.

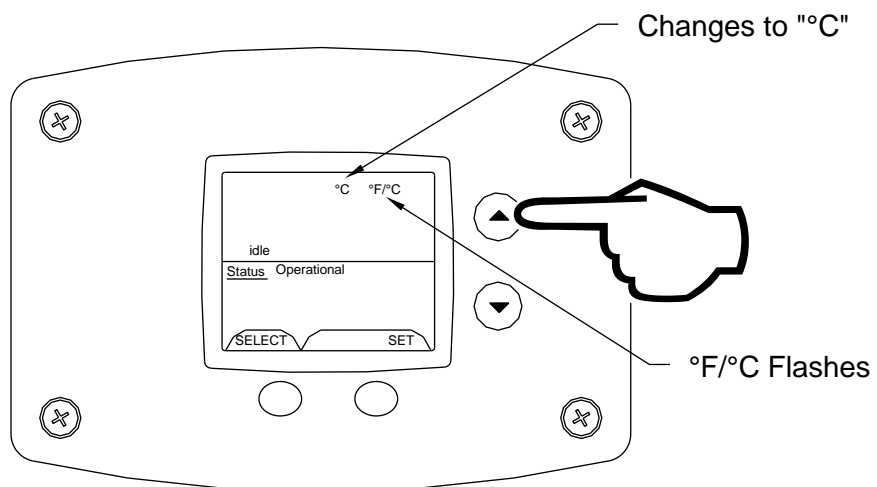

Step 3b: Press "Temperature Down" button to change temperature format to °F.

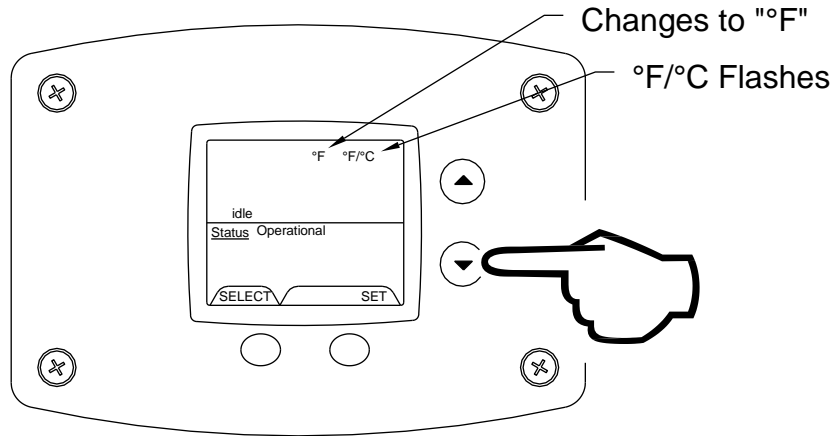

Step 4: Press "SET" button to confirm °F or °C format. °F/°C will stop flashing. Setpoint display will appear in the format selected (°F or °C) in 10 seconds.

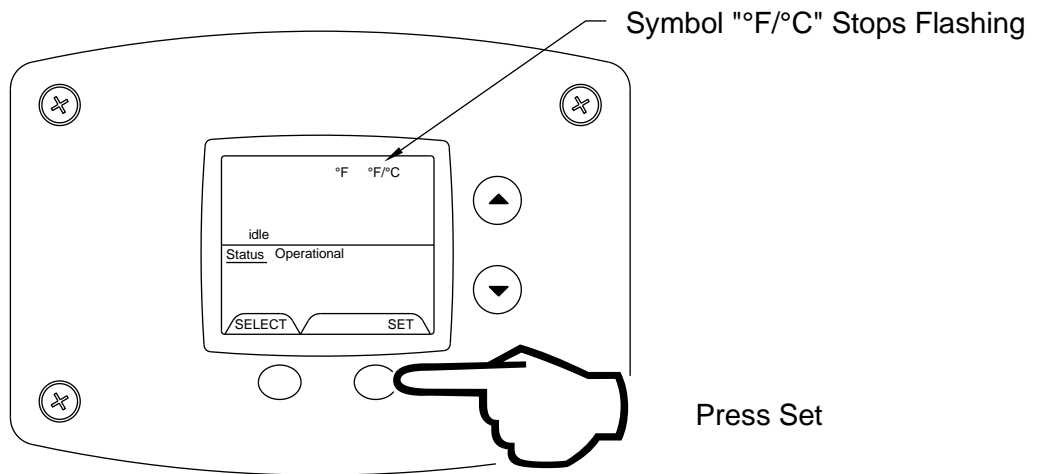

Step 5: Pressing "SELECT" button will return display to setpoint in format selected (°F or °C) immediately.

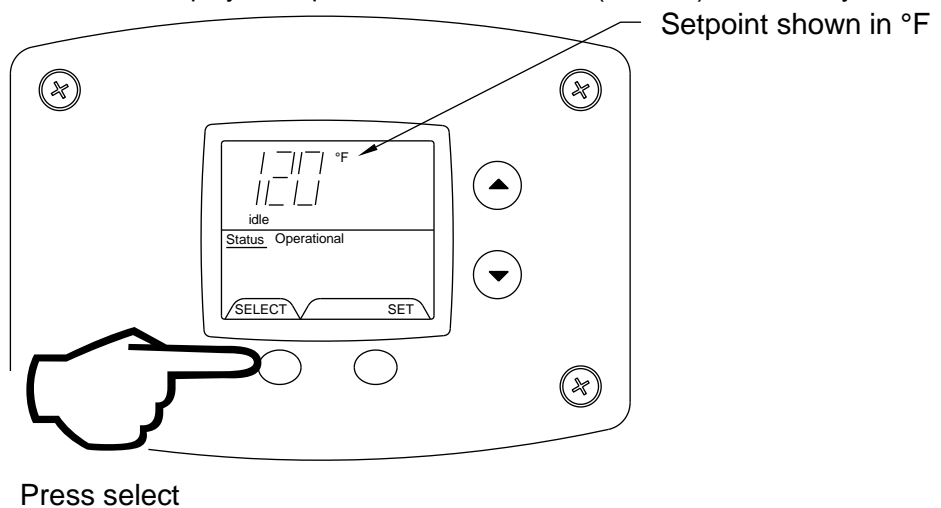

An energy cut out (ECO) is incorporated in the sensor and control board which will shut off all gas supply to the burner if the water heater temperature exceeds 200°F (93°C). Should the ECO function (open), the water temperature should be reduced to approximately 120°F (49°C) and call a qualified service agent to place the water heater in operation. The water heater must have the problem corrected by a qualified service person before putting the water heater back in operation. It is recommended that all service work be performed by a qualified service agency.

If the water heater is to remain idle for 30 days or more or is subjected to freezing temperatures while shut off, the water heater and piping should be fully drained (See “To Drain the Water Heater”) and the drain valve should be left fully open.

WARNING

Hydrogen gas can be produced in an operating water heater that has not had water drawn from the tank for a long period of time (generally two weeks or more). Hydrogen gas is extremely flammable. To prevent the possibility of injury under these conditions, we recommend the hot water faucet to be open for several minutes at the kitchen sink before you use any electrical appliance which is connected to the hot water system. If hydrogen is present, there will be an unusual sound such as air escaping through the pipes as hot water begins to flow. Do not smoke or have open flame near the faucet at the time it is open.

WARNING

Do not run out of propane gas. Damage to the water heater may occur.

SECTION XI: MAINTENANCE

DANGER

DO NOT ATTEMPT TO REPAIR GAS VALVE.
DO NOT ATTEMPT TO REPAIR IGNITION MODULE.
DO NOT ATTEMPT TO REPAIR VENTURI.
DO NOT ATTEMPT TO REPAIR THERMOSTAT BOARD.
DO NOT ATTEMPT TO REPAIR TRANSFORMER.
DO NOT ATTEMPT TO REPAIR PRESSURE SWITCH.

GENERAL

KEEP APPLIANCE AREA CLEAR AND FREE FROM COMBUSTIBLE MATERIALS, GASOLINE AND OTHER FLAMMABLE VAPORS AND LIQUIDS.

Water heater maintenance includes periodic tank flushing and cleaning, and removal of lime scale. The unit should be inspected and adjusted to maintain proper combustion. Refer to Table 5, “Suggested Maintenance Schedule”. A periodic inspection of the venting system should be made.

BURNER FLAME CHECK

At the time of installation and at monthly intervals, a visual check of the burner flames should be made to determine if they are burning properly. The main burner may be seen through the sight glass window on the front of the combustion insert mounting bracket (Figure 25). The burner flames should be a blue flame near the burner surface in a uniform flame pattern. Occasional yellow or white streaks are normal.

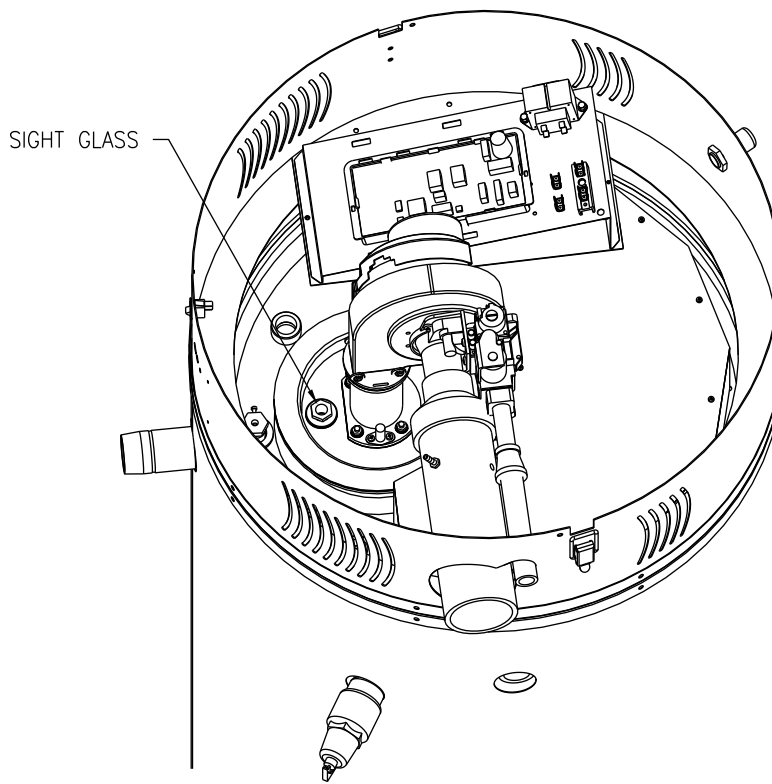

Figure 25. Sight Glass Location

MAINTENANCE SCHEDULE

Following are the instructions for performing some of the recommended maintenance. A competent technician should perform unit inspection and adjustment.

Suggested Maintenance Schedule

Service Interval	Component	Operation	Action
1 Month:	Tank	Sediment removal	Drain off several gallons of water.
	Condensate Line	Inspect & clean	Clear drainline and trap, verify proper pitch.
1 Year:	Powered Anode System	Check LED/inspect rods	1st year: check rods to determine service interval; check LED annually.
	Relief Valve	Function test	Operate lever, inspect for blockage or corrosion.
	Vent & Air Intake System	Inspect	Inspect joint seals/vent supports; clean air filter accessory kit if used.
	Vent Terminals	Free of blockage & debris	Clear intake and exhaust terminals, clean terminal screens.
	Combustion System	Inspect & clean	Clean flame sensor, igniter, & inspect burner.

Table 5.

FLUSHING WATER HEATER

1. Turn OFF the water heater electrical disconnect switch.
2. Open the drain valve and allow water to flow until it runs clean.
3. Close the drain valve when finished flushing.
4. Turn ON the water heater electrical disconnect switch.

DRAINING WATER HEATER

The water heater must be drained if it is to be shut down and exposed to freezing temperatures. Maintenance and service procedures may also require draining the water heater.

1. Turn off the water heater electrical disconnect switch.
2. Connect a hose to the drain valve.
3. Locate hose's discharge in an area where hot water will not cause any damage or injury.
4. Close the cold-water inlet valve to water heater.
5. Open a nearby hot water faucet to vent the system.

6. Open the heater drain valve.
7. If the water heater is being drained for an extended shutdown, it is suggested the drain valve be left open during this period.

FILLING WATER HEATER

1. Close the water heater drain valve by turning the knob or valve stem clockwise. If alternative water connections are provided but not used, make certain they are plugged (i.e. rear connections).
2. Open the cold-water supply shut-off valve.
3. Open several hot water faucets to allow air to escape from the system.
4. When a steady stream of water flows from the faucets, the water heater is filled. Close the faucets and check for water leaks at the water heater drain valve, combination temperature and pressure relief valve and the hot and cold-water connections.

SEDIMENT AND LIME SCALE REMOVAL

Waterborne impurities consist of the particles of soil and sand, which can settle out and form a layer of sediment on the bottom of the tank.

The amount of calcium carbonate (lime) released from water is in direct proportion to water temperature and usage. The higher the water temperature or water usage, the more lime deposits are dropped out of the water. This is the lime scale, which forms in pipes, water heaters and on cooking utensils.

Lime accumulation not only reduces the life of the equipment but also reduces efficiency of the water heater and increases fuel consumption.

The usage of water softening equipment greatly reduces the hardness of the water. However, this equipment does not always remove all of the hardness (lime). For this reason, it is recommended that a regular schedule of de-liming be maintained.

The depth of the buildup should be measured periodically. Water heaters will have about 3 inches (7.6 cm) of lime buildup when the level of lime has reached the bottom of the cleanout opening or about 1 inch (2.5 cm) of lime buildup if it has reached the drain valve opening. A schedule for de-liming should be set up, based on the amount of time it would take for a 1/2-inch (1.3 cm) buildup of lime.

Example 1: Initial inspection shows 1/2-inch (1.3 cm) of lime accumulation. Therefore, the water heater can be de-limed once a year.

To remove sediment and lime scale:

1. Drain the heater. Refer to DRAINING THE WATER instructions in this section.
2. Remove outer cover plate from lower side of water heater jacket.
3. Remove cover and gasket from cleanout opening.
4. Remove lime, scale or sediment using care not to damage the glass lining.
5. Inspect cleanout plate gasket: Replace gasket if necessary (Contact local distributor for correct part number).
6. Install gasket and cleanout plate. Be sure to draw plate up tight by tightening screws securely.
7. Close the drain valve. Open a hot water fixture to allow air to escape. Open the cold-water supply to water heater and allow the tank to fill. Follow the lighting instructions.
8. Check for water leakage.
9. Install outer jacket cover plate.

POWERED ANODE SYSTEM.

The powered anode system provides corrosion protection to the tank by supplying a low voltage current to the titanium anode rods and then periodically comparing this current with the potential between the anode rod and tank wall to make corrections. The powered anode system is designed to extend the tank life without requiring anode rod replacement. The powered anode system consists of two titanium powered anode rods (31 $\frac{7}{8}$ inches (81 cm) long), located in the front top of the water heater tank, and the powered anode control module located on the right side of the control panel.

The powered anode rod must have the electrical power supply connected at all times in order to provide corrosion protection to the water heater tank. If the electrical supply to the water heater is to be off for an extended period of time, the water heater must be drained. Turning off the lighted switch on the front panel to shut off the water heater will not turn off the powered anode system, as long as the line cord is plugged in and the breaker is left on.

The powered anode control module is located on the right vertical side of the control panel inside the surround panel. The control has a LED indicator light to show the status of operation. When the tank is filled with water and the power supply is on to the water heater, the light should have a steady green glow to indicate that protection current is flowing and operating normally. If the indicator light is not glowing, the power supply to the water heater or powered anode system is disconnected. Check the power supply or wire connections to the powered anode control.

If the control is flashing red, then there is a malfunction with the powered anode system. Make sure there are no bare spots in the wire insulation to the powered anode rods. Check all electrical connections. The powered anode rods are insulated from the water heater tank in the bushing. With an ohmmeter, check continuity between the powered anode terminal and the bushing. There should not be continuity. If there is continuity, replace the powered anode assembly.

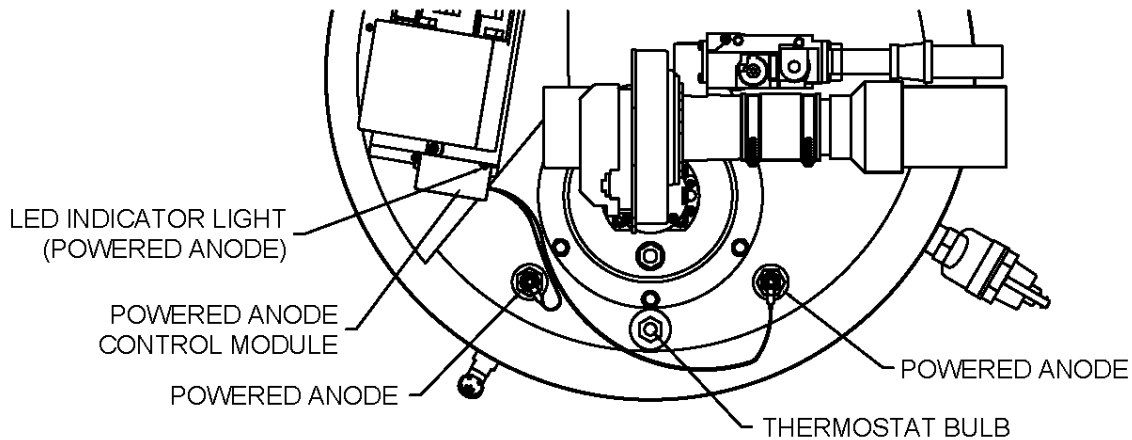

DRAIN VALVE AND TANK ACCESS PANEL

The water heaters are equipped with a 3/4-inch drain valve. An access panel covers the cleanout opening in the tank, which is sealed by a gasket and cover.

RELIEF VALVE

At least twice a year, the temperature and pressure relief valve should be checked to ensure that it is in operating condition. To check the relief valve, lift the lever at the end of the valve several times. The valve should seat properly and operate freely.

If water does not flow, remove and inspect for obstructions or corrosion. Replace with a new valve of the recommended size as necessary. A thorough inspection of the valve should be performed at least every three years by removing the temperature and relief valve from the tank. Do not attempt to repair the valve, as this could result in improper operation and a tank explosion. In areas with poor water conditions, it may be necessary to inspect the T&P valve more often than the recommended maintenance schedule.

CAUTION

Before manually operating the valve, make sure that a drain line has been attached to the valve to direct the discharge to an open drain. Failure to take this precaution could mean contact with extremely hot water passing out the valve during this checking operation.

If the temperature and pressure relief valve on the water heater discharges periodically or continuously, it may be due to thermal expansion of water in a closed water supply system, or, it may be due to a faulty relief valve.

Thermal expansion is the normal response of water when it is heated. In a closed system, thermal expansion will cause the system pressure to build until the relief valve actuation pressure is equaled. Then, the relief valve will open, allowing some water to escape, slightly lowering the pressure.

Contact your water supplier or local plumbing inspector on how to control this situation.

WARNING

Above all, do not plug the temperature and pressure relief valve. This is not a solution and can create a hazardous situation.

VENT AND AIR INTAKE SYSTEM

Examine the vent and air intake system every 3 months. Points of inspection are as follows:

1. Check for obstructions and/or deterioration of vent piping and vent terminal. Replace immediately where needed.
2. Vent pipe and vent hood screen should be cleaned of any foreign material. The screen is located inside the vent hood outlet and is accessible from the outside of the hood. Do not reach inside the vent hood when the water heater is in operation.
3. Check all vent system connections for leakage and reseal as required.

COMBUSTION SYSTEM INSPECTION

Inspect the operation of the combustion system monthly. Use the following procedure to inspect the combustion system.

1. Turn off the main power switch of the water heater.
2. Adjust the thermostat to the **minimum** setting.
3. Remove the top of the combustion surround by unlatching it.
4. While observing the ignition module, turn on the main power switch.
5. Adjust thermostat to the **maximum** setting.
6. Watch the LED's light as the controller goes through the S-OP as previously described.
7. Upon ignition, observe the main burner flame.
8. Readjust thermostat to previous setting.
9. Replace combustion surround top and latch it securely in place.

SECTION XII: DIAGNOSTIC AND TROUBLESHOOTING GUIDE

DIRECT SPARK ICON SYSTEMS INTEGRATED CONTROL SYSTEM **SEQUENCE OF OPERATION**

1. When the tank temperature drops below the temperature setpoint on the display, the control sends power to the combustion blower for a 30 second pre-purge period.
2. At the end of the pre-purge period, the control sends high voltage through the spark cable to the spark rod to spark to the burner and the gas valve also opens.
3. If the burner lights, a microamp current is generated through the flame sense rod allowing the control to detect burner flame.
4. The sparking then ceases and the flame is monitored by the flame sense circuit until the tank temperature reaches the thermostat setpoint and turns off the gas valve.
5. If the burner fails to light, the gas valve closes, sparking to the burner stops, and the combustion blower continues to operate for 60 seconds to purge the heat exchanger of unburned gas.
6. The ignition trial is repeated. The control will make 3 attempts to ignite the burner. If the burner fails to light after the third attempt, the control enters "Soft Lockout", which is an idle period for 60 minutes.
7. There will be an error code 62 or 63 shown on the water heater display indicating that the control cycled through the maximum number of ignition retries for ignition. The control will make another 3 ignition attempts after the 1 hour waiting period.
8. If the exhaust vent terminal should become blocked or the condensate drain becomes plugged, the exhaust vent pressure switch will open and the gas valve closes. The combustion blower will continue to operate. An error code 29 is shown on the water heater display.
9. Removing the blockage will resume normal operation.
10. The burner flame is monitored by the flame sense circuit and if the flame should extinguish, the gas valve closes and the combustion blower will operate to purge the heat exchanger before making an attempt to relight the burner. There may be 3 attempts to relight the burner before going into the Soft Lockout period explained previously.
11. The burner will continue to operate during the heating cycle until the tank temperature reaches the setpoint. The gas valve opens and the combustion blower continues to operate for 30 seconds to purge the heat exchanger of flue gases.
12. If for some reason, the tank temperature should exceed 200°F (93°C), then the control closes the gas valve and goes into a "Hard Lockout" state and will not operate until reset by a qualified service person. The display will read error code "65", which indicates the tank high limit temperature has been exceeded. No attempt should be made to reset the control until a service person has corrected the cause of the high limit condition.

13. Refer to the diagnostic service section at the end of this Installation and Operation Manual.

ACCESSING SERVICE MODE ON THE WATER HEATER DISPLAY (FOR SERVICE PERSONNEL ONLY)

The display has a “Service Mode” for changing the maximum setpoint and accessing information in aiding servicing of the water heater. This procedure is for service and installation personnel only. To enter the Service Mode, follow the steps illustrated below:

 **WARNING**

The following procedure is for service and installation personnel only. Resetting lockout conditions without correcting the malfunction can result in a hazardous condition.

Step 1: Press “Select” and “Temperature Up” buttons together and hold for 3 seconds until “Max Setpoint” is shown in the display.

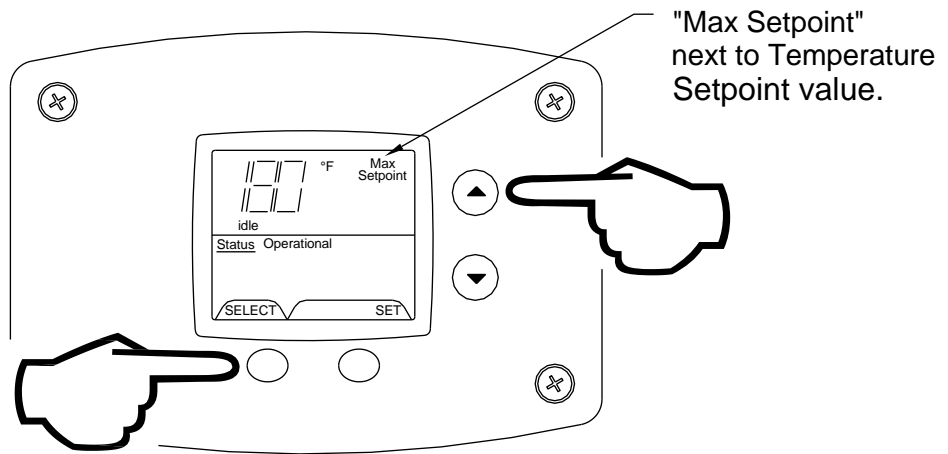

NOTICE

12.5 minutes after the last button press, the display will automatically return to the “User Mode”. Simultaneously pressing the “Select” and “Temperature Up” buttons will switch the display immediately to the “User Mode”.

Step 2: Pressing “Select” button will change display to next mode

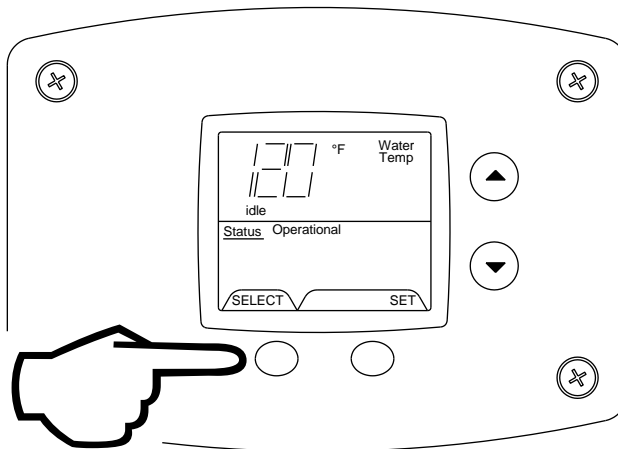

The following is the sequence of modes available in “Service Mode” by pressing the “Select” button

Error Code Number (Display/Reset). This is only shown if there is an operating error in the “User Mode”.

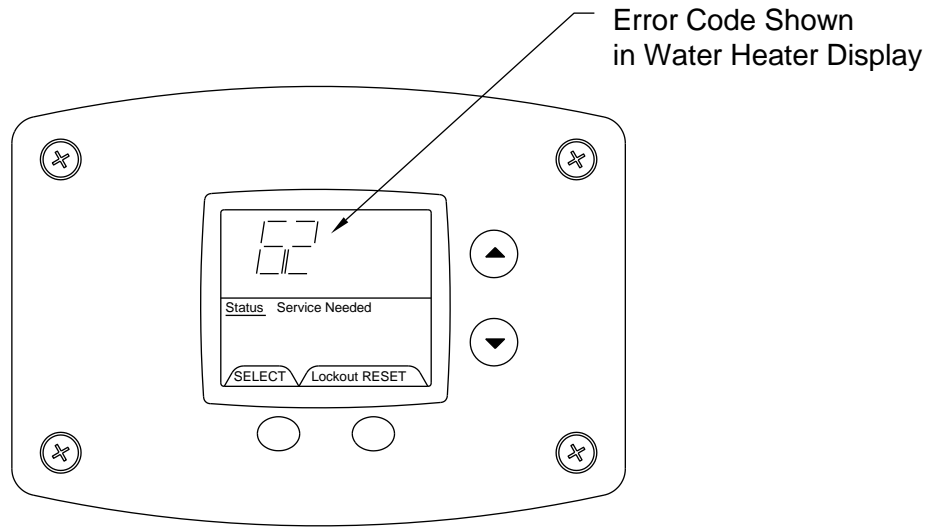

1. Max Setpoint (Display/Change).

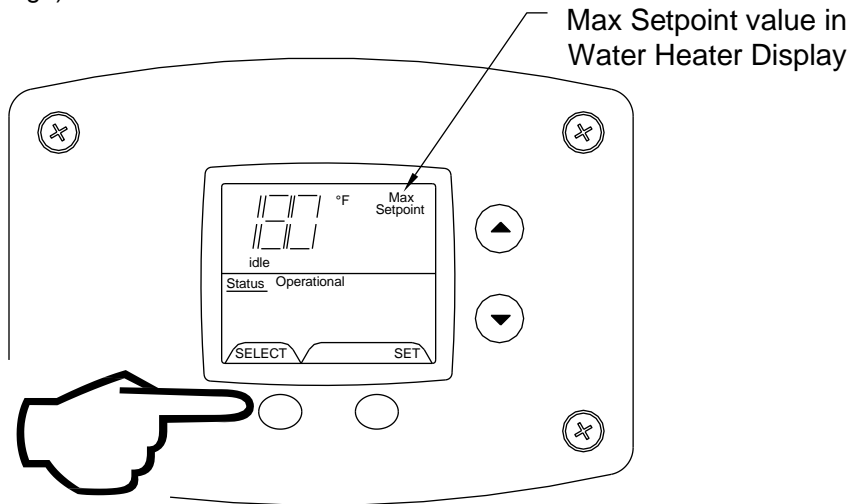

2. Water Temperature Sensor Reading.

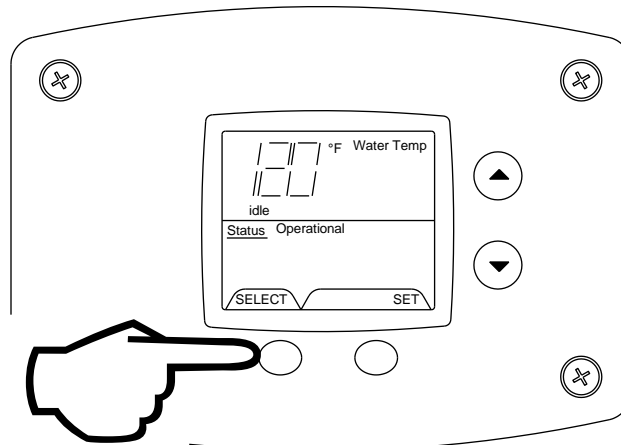

3. Flame Current of Pilot Flame Sensor (Displays only in the Heating Cycle).

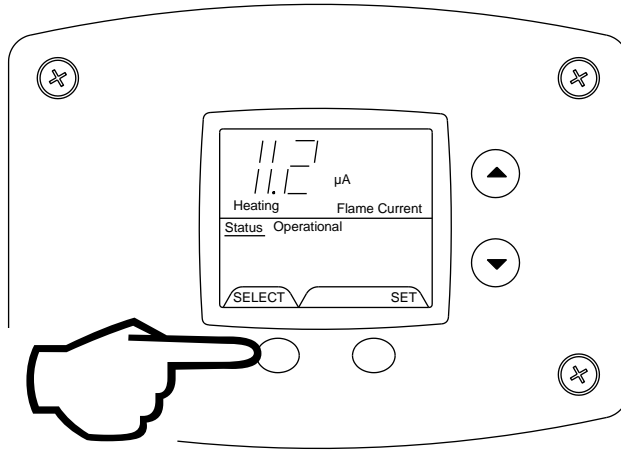

4. Setpoint (Display/Change).

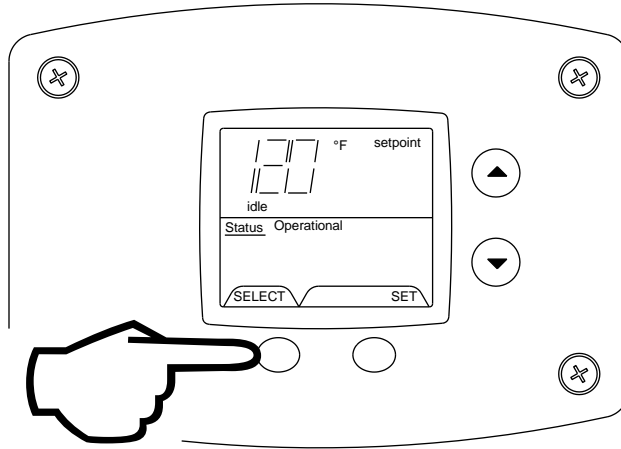

5. °F/°C (Display/Change).

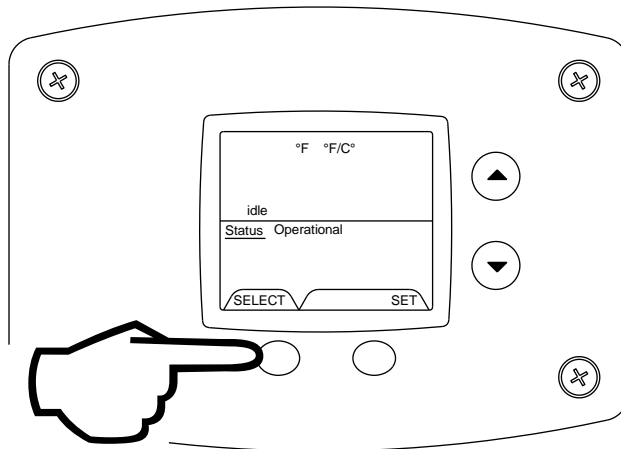

6. Differential (Display only – shows the differential of the thermostat).

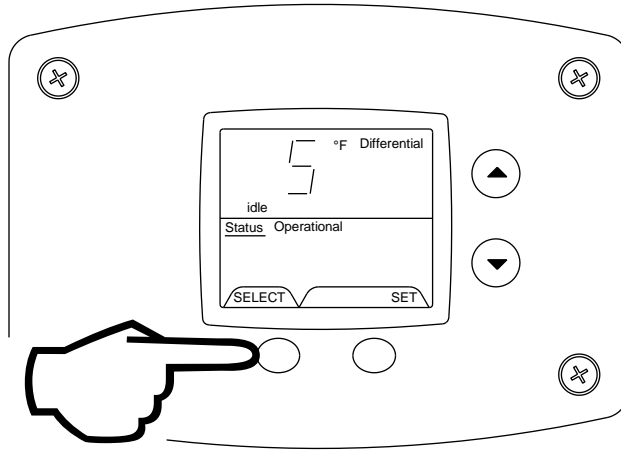

7. Software Version (Display only).

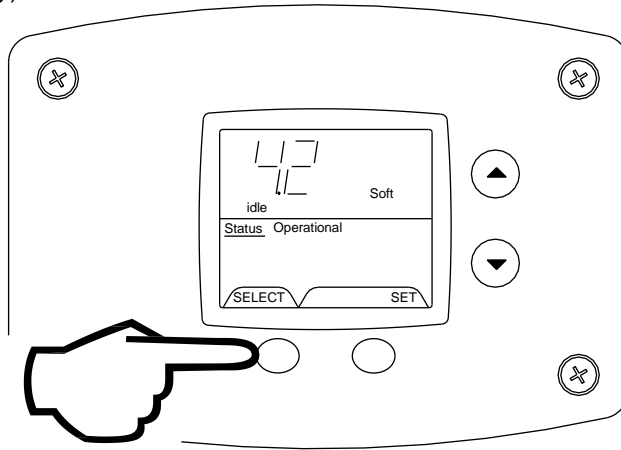

8. Error Code History (Displays if there are present error codes or up to 10 previous error codes). Water Heater Display will show -- if there are no error codes.

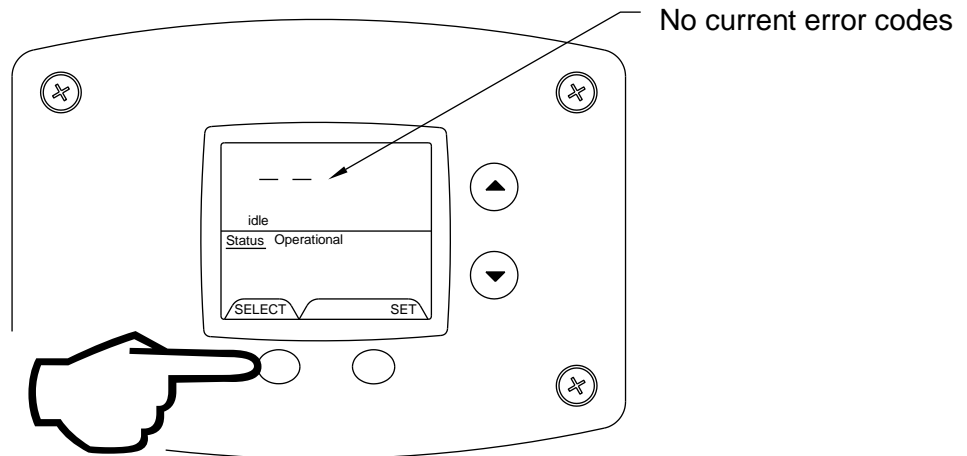

To change the Maximum Setpoint Limit (Max Setpoint) for the temperature setpoint



WARNING

Setting the water temperature to the maximum set point can result in scalding hot water delivered to the faucets. It is highly recommended that the maximum setpoint be adjusted to the lowest temperature possible for the needs of the installation. See following section to change the maximum setpoint limit (max setpoint). Make sure the water heater control display is not in a public area that can result in the temperature settings being improperly adjusted. See previous warning on scalds and an ASSE approved mixing valve.

Step 1: In service mode press the "Select" button until "Max Setpoint" is displayed.

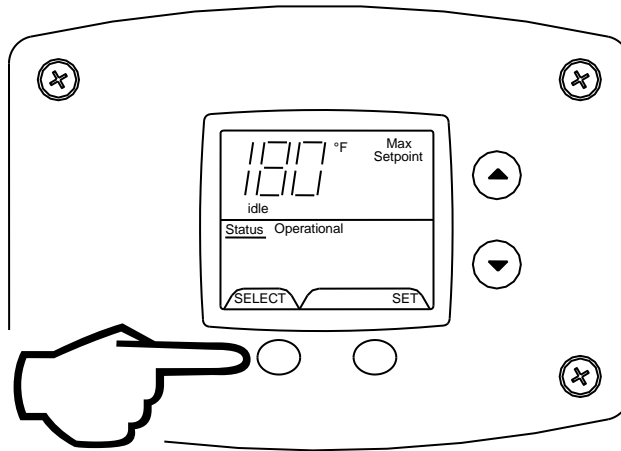

Step 2: Press "Set" button to enter setting mode. "Max Setpoint" will flash to indicate setting mode.

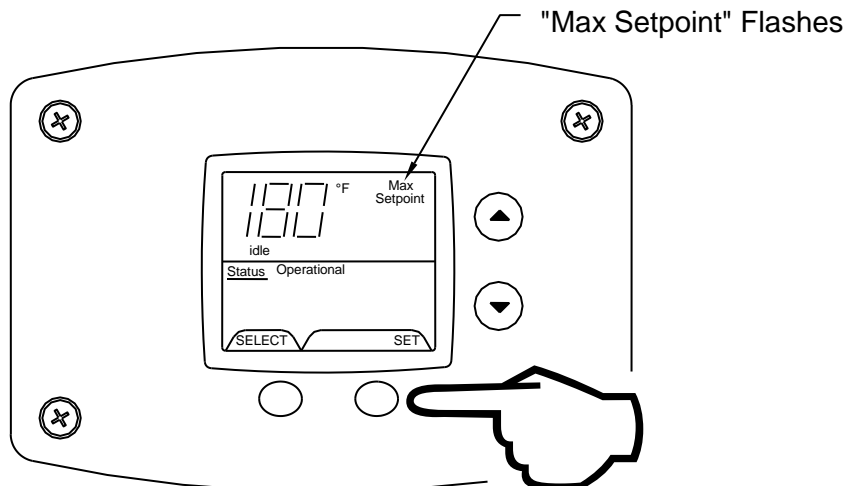

Step 3: Press the “UP” or “DOWN” buttons to change the maximum setpoint value. This will limit the maximum setpoint the user can select. Note: The maximum setpoint is approximately 180°F (82°C).

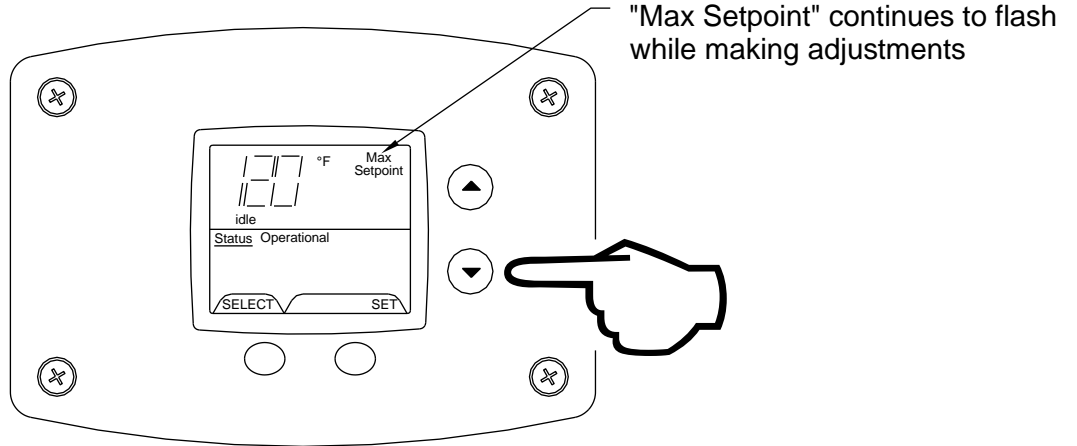

Step 4: Press “Set” button to confirm new “Max Setpoint” value and stop setting mode.

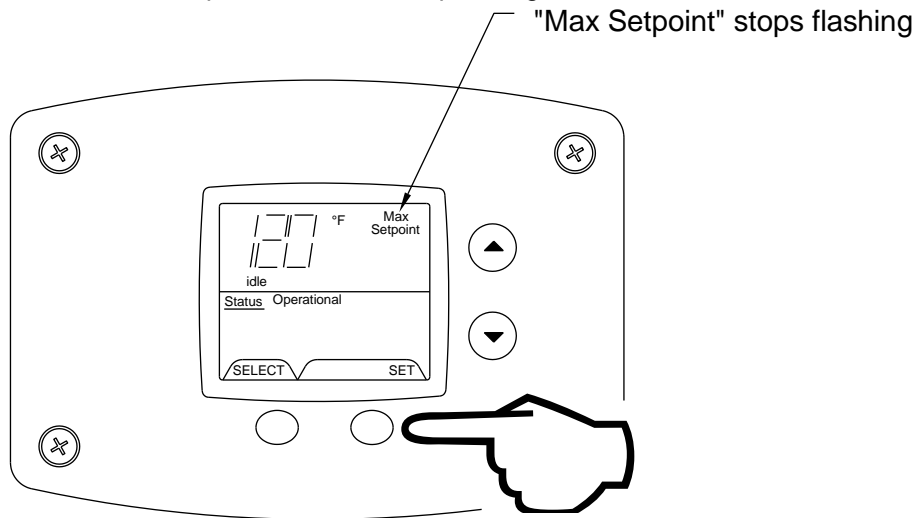

Step 5: 12.5 minutes after the last button press, the Water Heater Display will go back to “User Mode”. It will read “Max Setpoint” without showing a temperature value if the temperature setpoint is at the maximum setting. The Water Heater Display can be set back to the “User Mode” immediately by pressing both the “Temperature Up” and “Select” buttons together for 3 seconds.

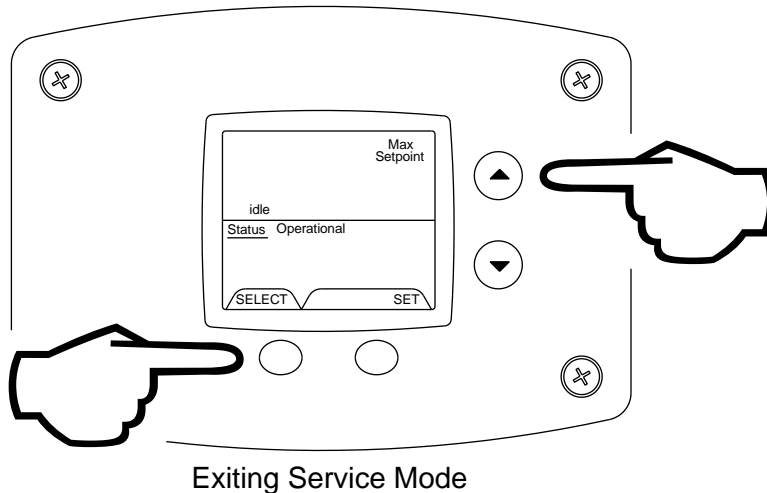

Display of Water Temperature

Step 1: In Service Mode, Press the “Select” button until “Water Temp” is displayed in the upper right section of the water heater display. This is the reading for the tank sensor.

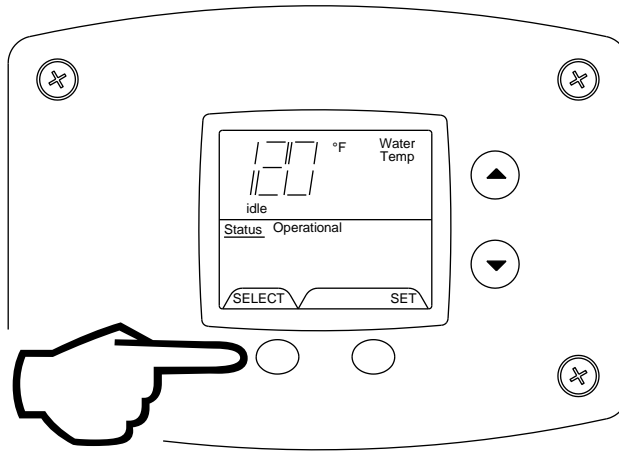

To Display Flame Sense Current of the Pilot Flame Sensor

The pilot flame sense current is available only when the burners are in operation. Step 1: Make sure the status displays “Heating” or draw enough hot water to start the burners. Step 2: Enter the “Service Mode” described previously. Step 3: Press the “Select” button until a number value is displayed with “Flame Current” to the right of the number. The value displayed is in microamps (μA).

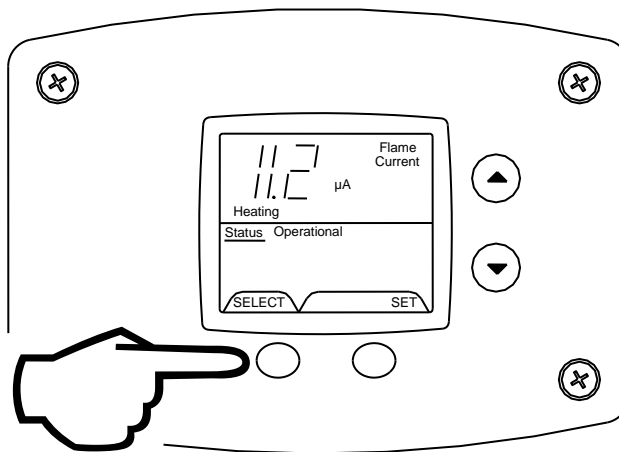

To Display and Change Temperature Setpoint

Step 1: In "Service Mode" press the "Select" button until "Setpoint" is shown in the water heater display.

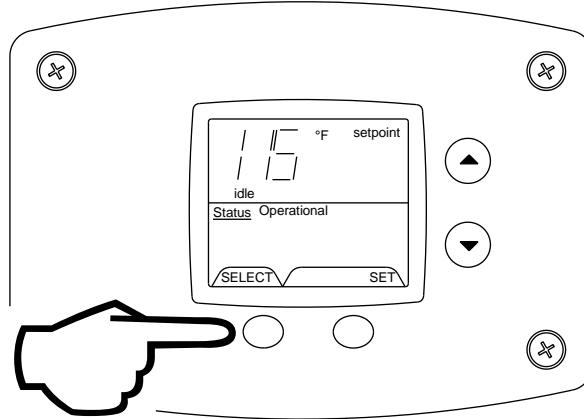

Step 2: Press the "Set" button to enter the setting mode. "Setpoint" will flash in the water heater display.

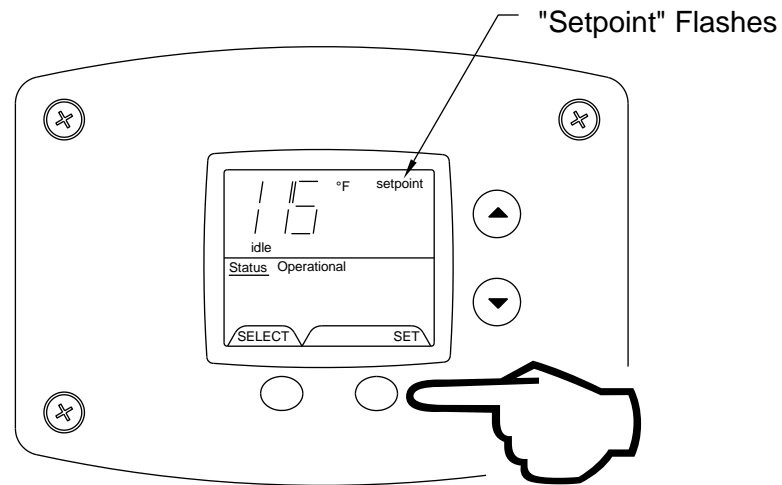

NOTICE

Note: The maximum temperature that can be set in the Water Heater Display is limited to the "Max Setpoint" described previously. To change the "Max Setpoint", refer to the procedure "To Change the Maximum Setpoint Limit..." described previously under "Accessing the Service Mode on the Water Heater Display".

Step 3: To raise the temperature setpoint, press the "Temperature Up" button until the desired temperature is shown on the water heater display.

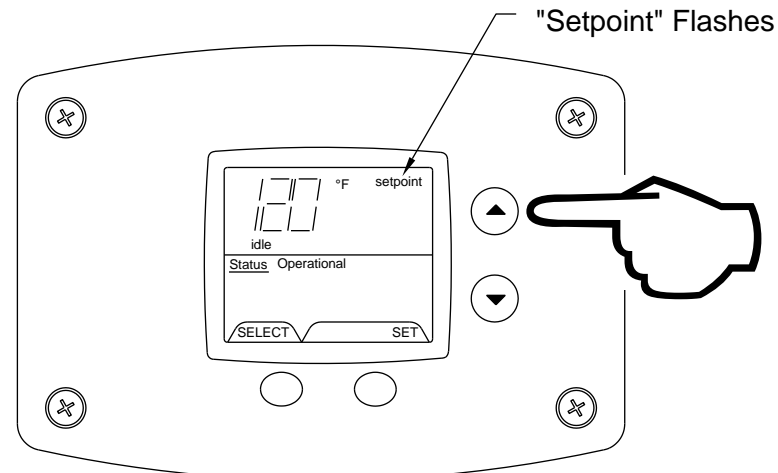

Step 4: To lower the temperature setpoint, press the “Temperature Down” button until the desired temperature is shown on the water heater display.

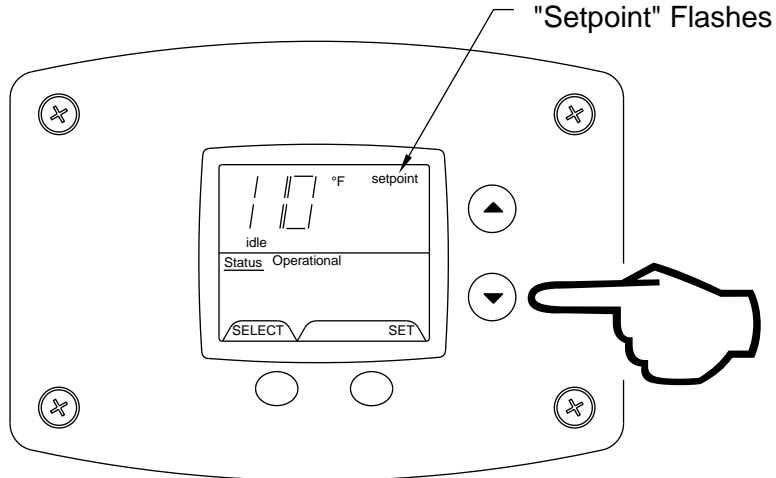

Step 5: When the desired setpoint is reached on the water heater display, press the “Set” button to confirm the new setpoint. “Setpoint” stops flashing in the water heater display.

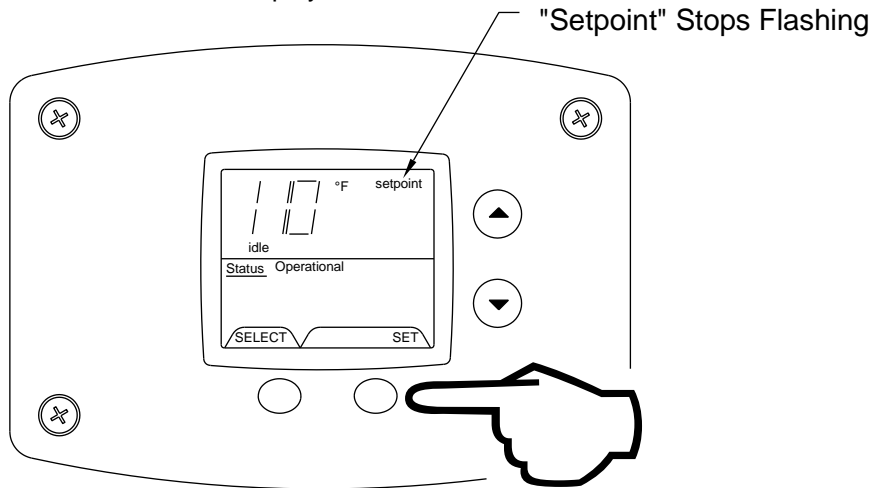

To Change Temperature Format in Display from °F to °C or °C to °F

Step 1: While in “Service Mode”, press “Select” button until “F/C” is shown in the upper right portion of the water heater display.

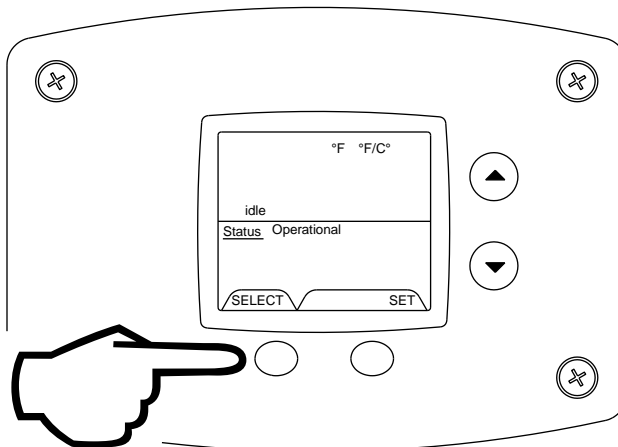

Step 2: Press "Set" button to change temperature format. "°F/°C" symbol will flash in the water heater display.

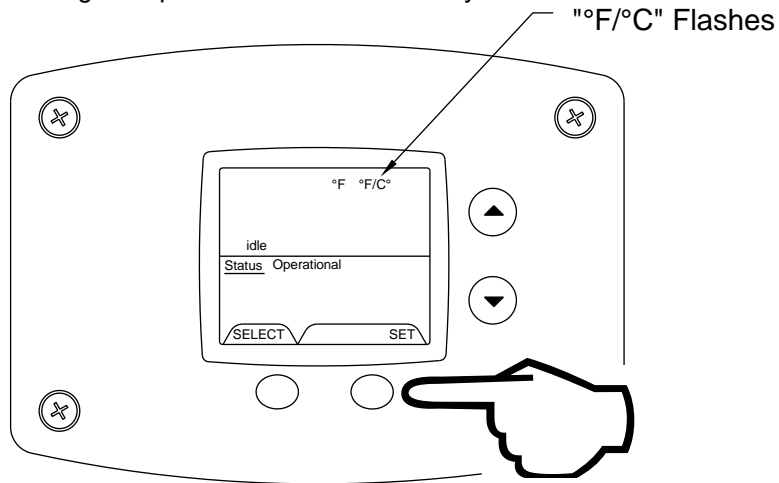

Step 3a: Press "Temperature Up" button to change temperature format to °C.

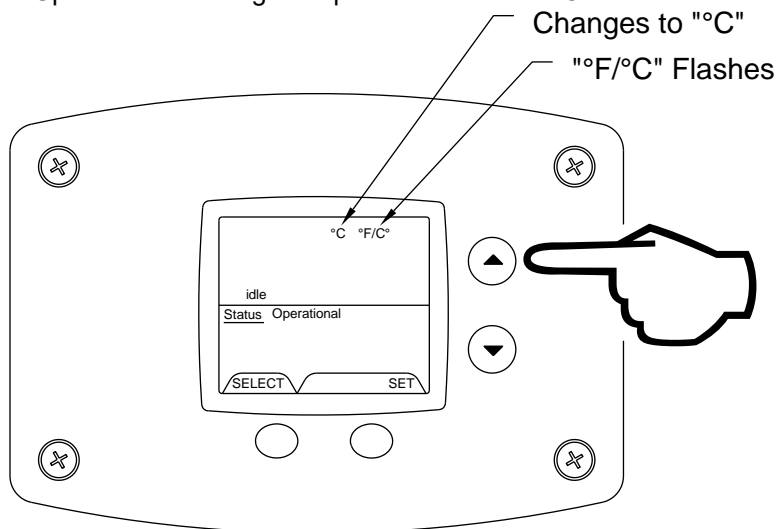

Step 3b: Press "Temperature Down" button to change temperature format to °F.

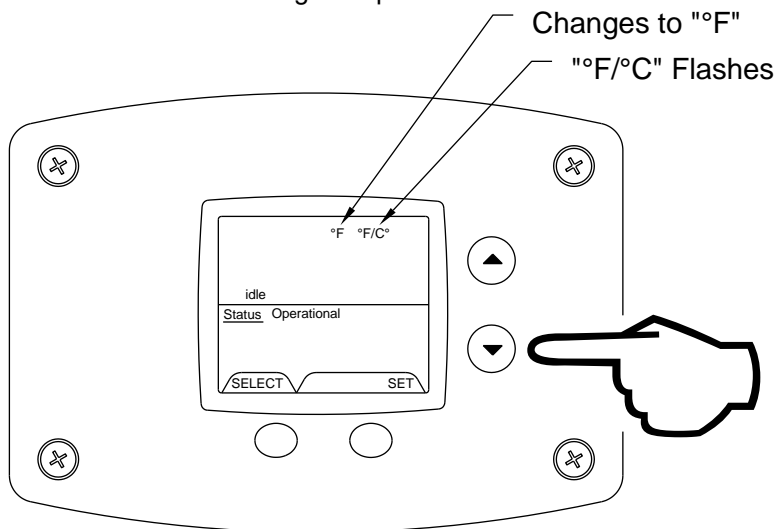

Step 4: Press "Set" button to confirm °F or °C format. °F/°C will stop flashing.

"°F/°C" Symbol Stops Flashing

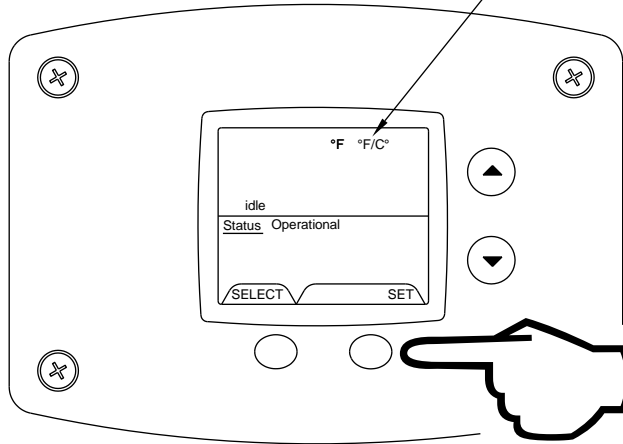

Step 5: Pressing "Select" button will return display to setpoint in format selected (°F or °C) immediately.

Setpoint shown in °F

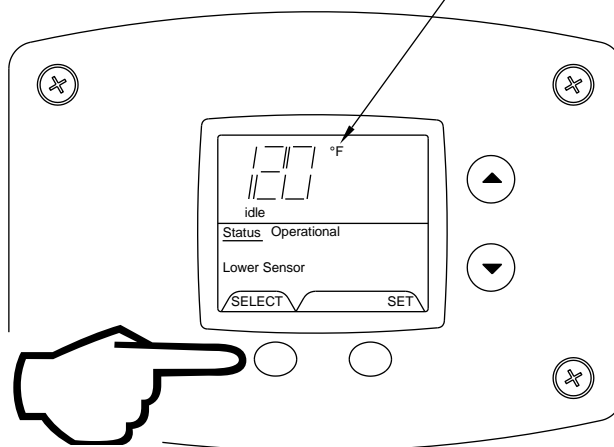

WARNING

The following procedure is for service and installation personnel only. Resetting lockout conditions without correcting the malfunction can result in a hazardous condition.

How to reset the control from Lockout Conditions

If an error code is displayed (except for #4, low flame sense current), the water heater will be in a “lockout condition” with the water heater display showing the error code number and “Service Needed” in the status section of the display window. Error codes 62 (maximum number of retries detected) and 63 (maximum number if ignition recycles detected) are “Soft Lockouts” in which the control can be reset in the “User Mode” by pressing the lower right button under “Lockout Reset” shown in the lower right portion of the display. The control will also go through 3 attempts to relight the burners every hour in the soft lockout condition.

Resetting Error Codes in Soft Lockout Condition

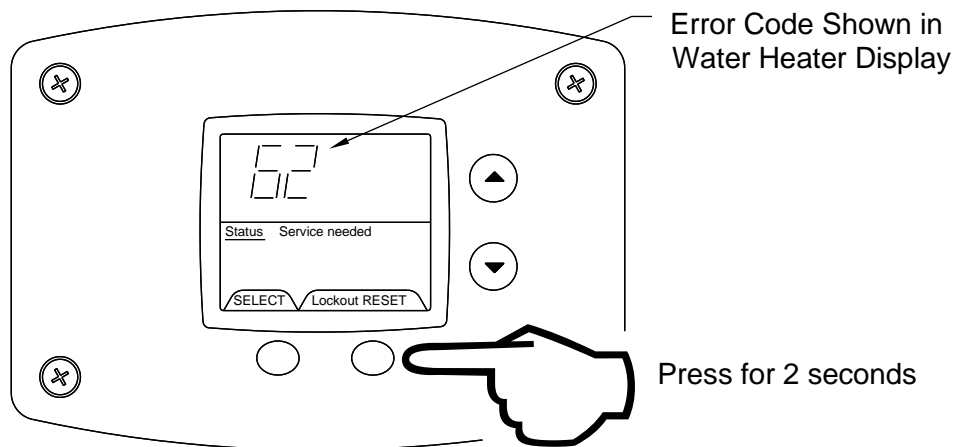

All other error codes will put the water heater into a “Hard Lockout” condition, in which the water heater will not operate and cannot be reset in the “User Mode”. To reset a hard lockout, first enter the “Service Mode” described earlier by pressing both the “Temperature Up” and “Select Buttons” at the same time for 3 seconds. Then press the lower right button under “Lockout Reset” in the water heater display and hold for 3 seconds.

Resetting Error Codes in Hard Lockout Condition

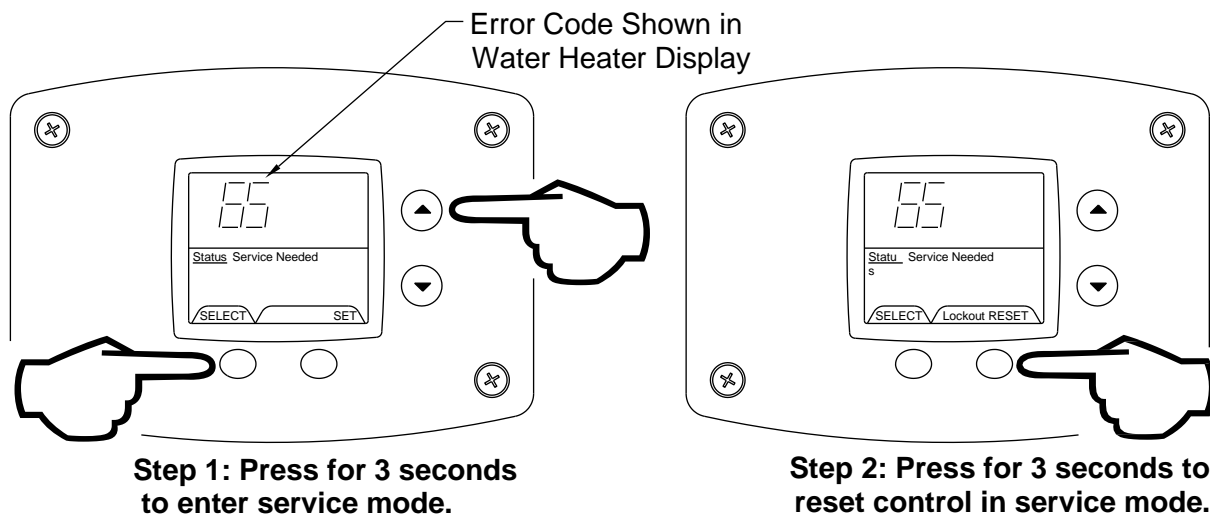

Error Codes and Error History Display

If there is an operating problem with the water heater, an error code number will appear on the water heater display with “Service Needed” to the right of the “Status” indicator. The error code label is located below the water heater display and the following section in this Installation and Operation Manual explains the error codes with corrective actions to repair the water heater.

Example of Error Code in the Display

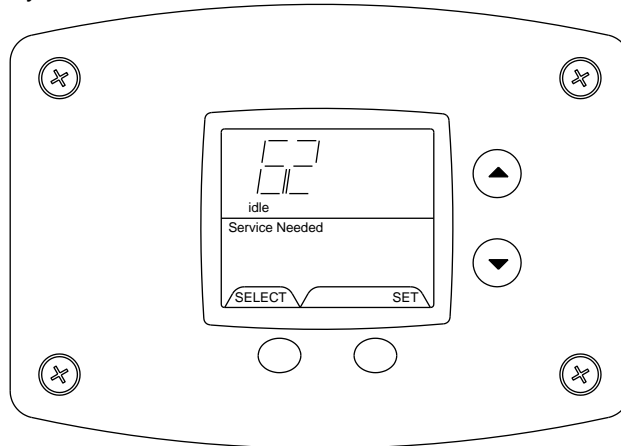

Error Code History

In “Service Mode” pressing the “Select” button after the “Software Version” (item 8 in the previously described sequence of service modes) will show an error code history, if there have been any previous operating problems with the water heater. If the display shows --, there is not a current error code.

The Water Heater Display will provide up to 10 previous error codes. The oldest error code will be stored in code index #1 and the most recent in code index #10 (if there are 10 error codes).

To view previous error codes:

Step 1: In “Service Mode” press the “Select” button until the next display after the “Software Version”. If there are no current error codes, the display will show “--”.

No Current Error Code

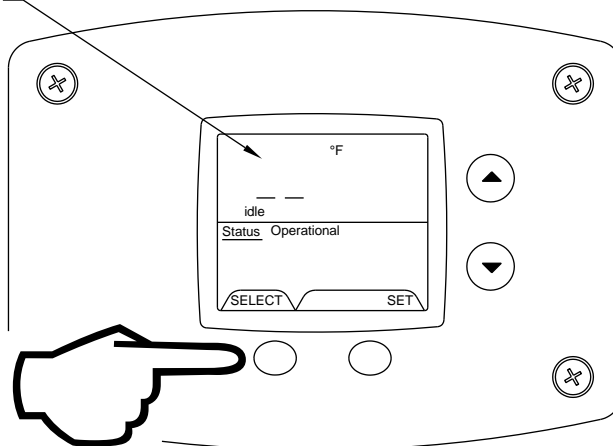

Step 2: Press the "Temperature Down" button to select the error code index, starting with the most recent error code "10".

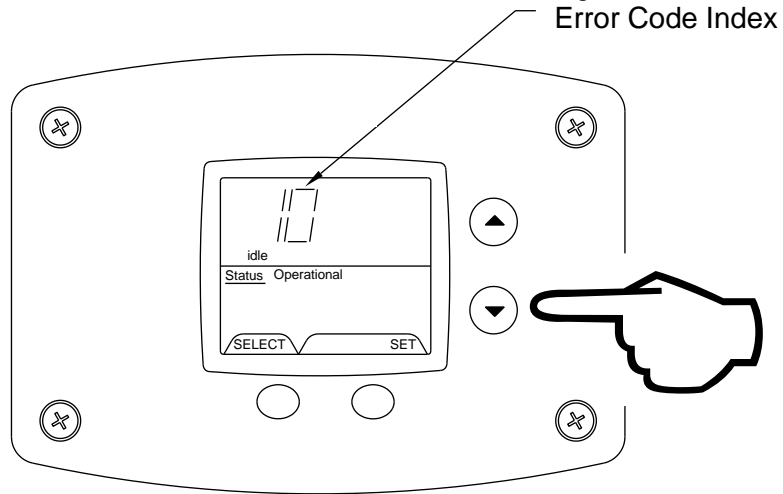

Step 3: Press the "Select" button to view the error code for "code 10". If there is a number displayed, note what the number is. The label next to the water heater display will identify the code number. If no number is displayed with only a "--" in the water heater display, then there has not been an error code for error code index 10.

No Error Code Shown
for Code Index 10

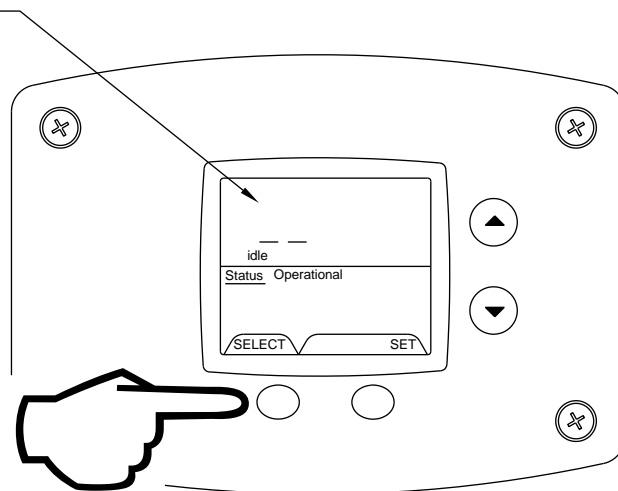

Step 4: Press the "Temperature Down" button to change to the previous code index, code #9.

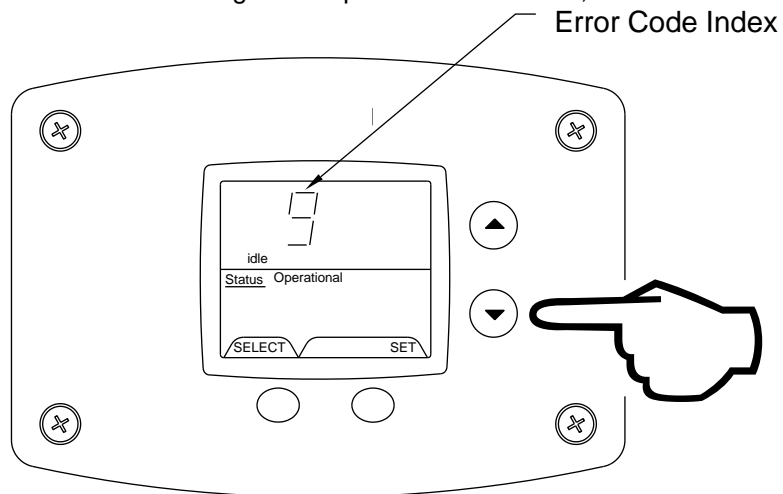

Step 5: Press the "Select" button for code index #9 to view if there are any code numbers.

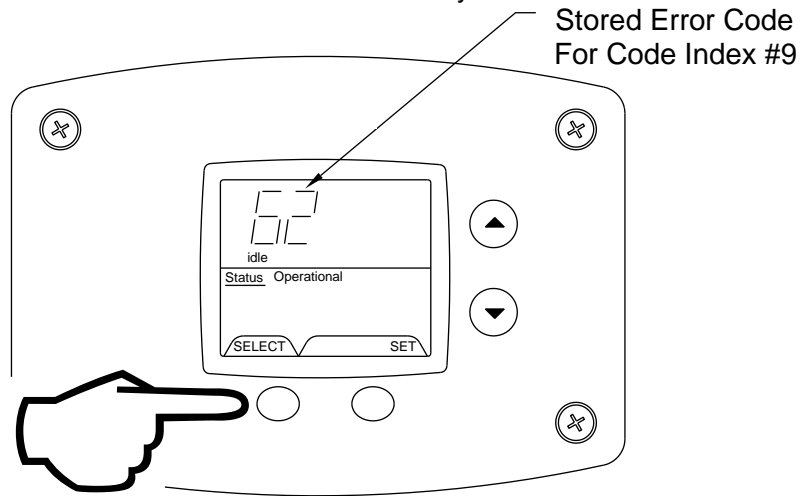

Step 6: Continue pressing the "Temperature Down" button to change to the next error code index and press "Select" to view the error code number, if any, for that index number. Continue to index #1, the oldest error code index. The water heater display will store up to 10 error codes with the oldest code starting in code index #1 with the most recent code in code index #10.

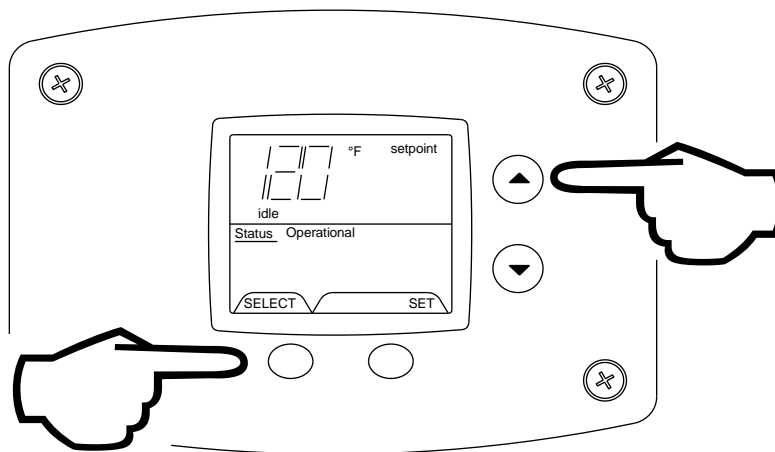

Exiting Service Mode

Step 7: 10 seconds after the last button press, the Water Heater Display will revert back to the current error code display. To exit Service Mode, press Temperature Up button and Select Button for 3 seconds.

DIAGNOSTIC ERROR CODES AND TROUBLESHOOTING PROCEDURES FOR EF MODELS WITH ICON SYSTEMS INTEGRATED DIRECT SPARK IGNITION CONTROL SYSTEM

Error Code	Definition of Code	Cause of Problem and Actions Taken to Correct
No code – blank display		<ul style="list-style-type: none"> • Check power supply to the water heater. • Make sure water heater is plugged in and the breaker is on. • Check if there is 120 volts power supply to the LINE connections on the control board. • If 120 volts is present, check for 24 volts output to SECONDARY terminals on the Control Board. • Check for loose wires, defective transformer. • Check wire harness connections from display to the control board.
4	Low Flame Sense Current	<ul style="list-style-type: none"> • Determine flame sense current in the Service Mode with the water heater operating. • If less than 4.0 microamps, check burner flame sense rod and wire. Clean flame sense rod with emery cloth. • If problem is not solved, check for debris clogging burner or replace flame sense rod.
6	Flame Sensed Out of Normal Sequence (Before Opening Gas Valve or After Closing Gas Valve)	<ul style="list-style-type: none"> • Check to make sure gas valve has closed. • No voltage should be present at the gas valve before or after ignition cycle. • Make sure wire positions on the wire harness are correct. • If gas valve is stuck open, replace.
23	Flame Detected Before Ignition	<ul style="list-style-type: none"> • Check to make sure gas valve has closed. • No voltage should be present at the gas valve before the ignition cycle. • Make sure wire positions on the wire harness are correct. • If gas valve is stuck open, replace.
24	Flame Detected After Heating Cycle Completes	<ul style="list-style-type: none"> • Check to make sure gas valve has closed. • No voltage should be present at the gas valve before the ignition cycle. • Make sure wire positions on the wire harness are correct. • If gas valve is stuck open, replace.
26	Exhaust Collector Limit Switch Open	<ul style="list-style-type: none"> • Check to see if the exhaust collector high limit switch, located in the exhaust collector area near the pressure switch has opened. • Depress the red manual reset button on the high limit switch. • If it resets with a “click”, the switch has opened. • Check for evidence of high temperatures in this compartment. • If there is evidence of high temperatures, call Tech Support. • Do not continue to operate the water heater if high temperature is occurring in this area.
29	Pressure Switch Failed to Close	<ul style="list-style-type: none"> • The blocked vent pressure switch contacts have opened. • Check to make sure the venting system is not blocked. • Check to make sure the condensate drain is not clogged and is sloping toward the drain. • Make sure the vent length does not exceed the specified limits. • Make sure the vent terminal is not blocked. • Check to make sure the pressure switch tubing is clear. • Replace the pressure switch if the venting system has checked out O.K. Control will reset once problem is corrected.
32	Lower Sensor Readings Faulty	<ul style="list-style-type: none"> • Resistance of lower sensor out of operating range. • Check continuity of wire harness to lower sensor, and if O.K., replace lower sensor.
57	Flame Rod Shorted to Ground	<ul style="list-style-type: none"> • Pilot flame sensor rod is shorted to ground. • Check to see if flame sensor wire has bare spots touching metal parts or if flame sensor rod is touching the burner or other metal parts. • Replace if flame sense wire is damaged or flame rod is bent.

58	AC Line Frequency Error – Signal Too Noisy or Frequency Incorrect	<ul style="list-style-type: none"> • Check line voltage frequency to the water heater. • Determine if there are wide fluctuations. • Call an electrician if the problem persists. • The water heater should be on a separate line.
59	Line Voltage Too Low or High	<ul style="list-style-type: none"> • Check line voltage to the water heater. • Determine cause of low or high voltage. • Call an electrician or your utility. • The water heater should be on a separate line.
61	DC Output Voltage Unstable	<ul style="list-style-type: none"> • Check line voltage to the water heater for erratic readings. • Also check wiring to make sure there are no shorts. • If power supply and wiring are O.K., replace control board.
62	Maximum Number of Retries Detected	<ul style="list-style-type: none"> • Burner is either not lighting or not staying lit during ignition cycle. • Check inlet gas pressure for minimum pressure on rating label. • Can you hear sparking to the burner? • Check high voltage cable connections. • Check inlet gas pressure to the gas valve making sure the pressure is within the limits specified on the rating label. • Check gas valve wire harness for broken wires or shorts. • Check outlet gas pressure. • If 24 volts is present to the terminals at the gas valve, replace gas valve. • Check for voltage output to the blue gas valve wires on the control board pins. • If during the ignition trial period, there is no voltage present at the control board pin terminals for the blue wires leading to the gas valve, then replace the control board. • Replace spark rod if insulator is damaged or rod is loose. • Check to make sure combustion blower is operating when thermostat calls for heat. • If blower is not running check for 120 volts to blower harness and then at blower pin connections. • Replace control, wire harness, or blower if defective. • Check to make sure vent terminals are clear of debris or snow and ice. Make sure the condensate drain flows freely.
63	Maximum Number of Ignition Recycles Detected	<ul style="list-style-type: none"> • Burner flame is lost during run cycle, then re-established on ignition cycle. • Check inlet gas pressure. • Is gas pressure dropping below the minimum operating pressure on the rating label after the gas valve opens? • Is the gas pipe size to the water heater adequate? • Check the condition of the burner. • Clean or replace as needed. • Check the burner flame and observe the microamp output on the run cycle. • Replace burner if clogged with dirt and debris. • Replace spark rod or flame sensor if damaged. • Check to make sure vent terminals are clear of debris or snow and ice. Make sure the condensate drain flows freely.
64	Electronics Failure	<ul style="list-style-type: none"> • Replace control board.
65	High Water Temperature (Over 200°F (93°C))	<ul style="list-style-type: none"> • Water temperature in tank has exceeded 200°F (93°C). • Check tank sensor. • Make sure sensor is fully inserted into the well (clip on sensor wire secures sensor in place). • Check sensor reading. • If not within specifications, replace sensor. • If sensor and wire harnesses check O.K., replace control board.

Procedure for Checking Thermostat Sensors

Set the thermostat above water temperature (See temperature adjustment section) and observe system through one (1) complete cycle. Make sure system operates as desired.

To check the sensor assembly, compare the resistance of the sensor wires (either outside black to center wire with yellow marking) as measured by an ohmmeter to the water temperature as measured by an accurate thermometer. Thermistor resistance increases as the temperature decreases. The tables below show the correct sensor resistance at various temperatures. Both thermistors in the sensor assembly should have approximately the same readings. Replace the sensor if the ohm reading in the chart does not approximate the reading from the sensor at the temperature measured in the tank. Use a thermometer or thermocouple to measure the temperature from the hot water outlet or T&P valve.

In Degrees F										
°F	0	1	2	3	4	5	6	7	8	9
40	26109	25400	24712	24045	23399	22771	22163	21573	21000	20445
50	19906	19383	18876	18383	17905	17440	16990	16553	16128	15715
60	15314	14925	14548	14180	13823	13477	13140	12812	12494	12185
70	11884	11592	11308	11032	10763	10502	10248	10000	9760	9526
80	9299	9078	8862	8653	8449	8250	8057	7869	7685	7507
90	7333	7165	7000	6839	6683	6531	6383	6238	6098	5961
100	5827	5697	5570	5446	5326	5208	5094	4982	4873	4767
110	4663	4562	4464	4368	4274	4183	4094	4006	3922	3839
120	3758	3679	3602	3527	3453	3382	3312	3244	3177	3112
130	3048	2986	2925	2866	2808	2752	2697	2643	2590	2538
140	2488	2439	2391	2344	2298	2253	2209	2166	2124	2083
150	2043	2004	1966	1928	1891	1856	1820	1786	1753	1720
160	1688	1656	1625	1595	1566	1537	1509	1481	1454	1427
170	1402	1376	1351	1327	1303	1280	1257	1235	1213	1191
180	1170	1150	1129	1110	1090	1071	1053	1035	1017	999
190	982	965	949	933	917	901	886	871	857	842
200	828	814	801	788	775	762	749	737	725	713

In Degrees C										
°C	0	1	2	3	4	5	6	7	8	9
0	32648	31026	29495	28049	26682	25389	24166	23010	21915	20879
10	19898	18968	18088	17253	16461	15710	14998	14322	13680	13071
20	12492	11942	11419	10922	10450	10000	9572	9165	8778	8409
30	8057	7722	7403	7099	6808	6532	6268	6016	5775	5546
40	5327	5117	4917	4726	4543	4368	4201	4042	3889	3742
50	3602	3468	3340	3217	3099	2986	2878	2774	2675	2579
60	2488	2400	2316	2235	2157	2083	2011	1942	1876	1813
70	1752	1693	1637	1582	1530	1480	1432	1385	1340	1297
80	1256	1216	1177	1140	1105	1070	1037	1005	974	944
90	916	888	861	835	810	786	763	741	719	698

SECTION XIII: PARTS BREAKDOWN

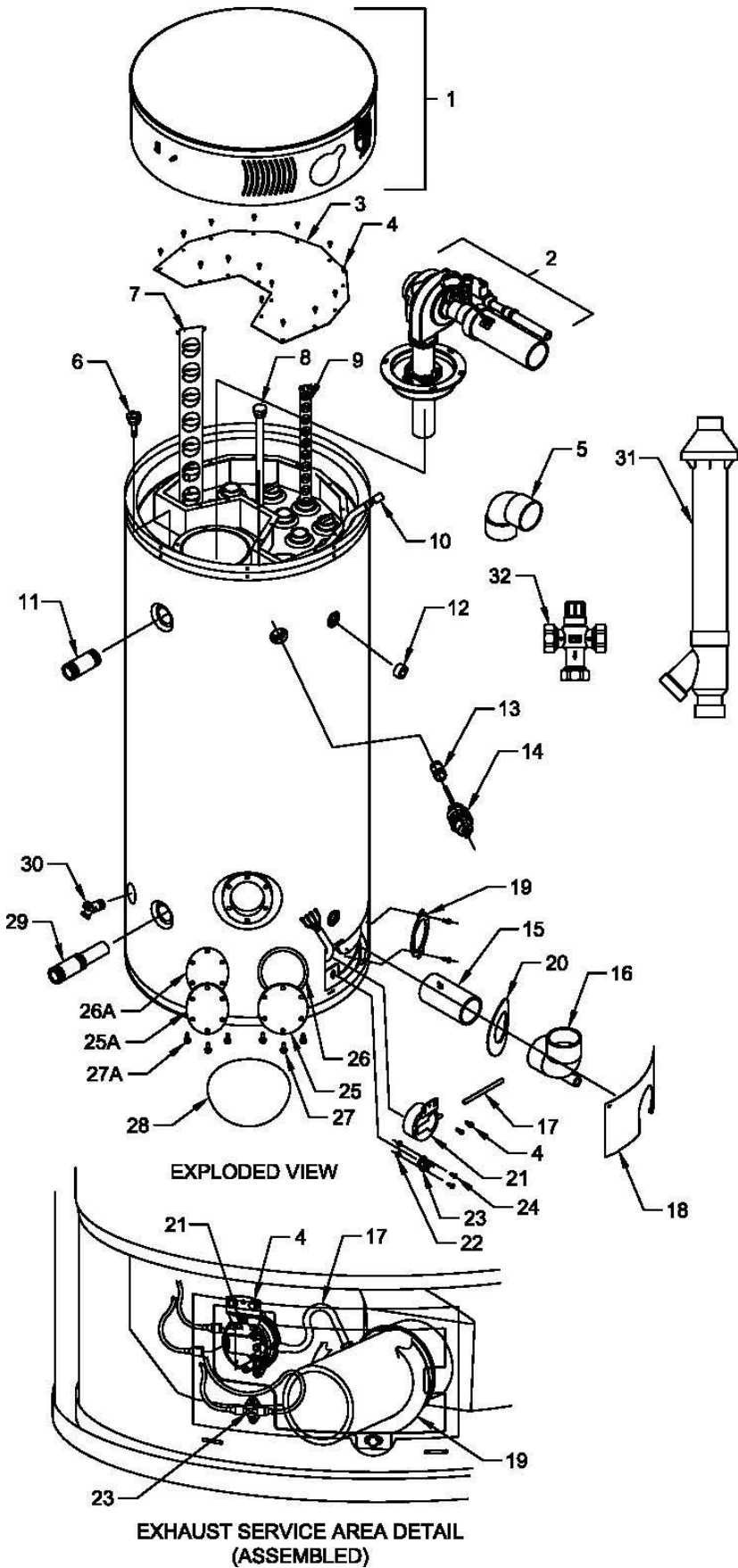

Commercial Gas Water Heater

1	Combustion Surround Ass'y
2	Burner Ass'y
3	2nd Pass Top Collector Cover
4	2nd Pass Top Collector Screws
5	Vent Termination Elbow
6	Immersion Well
7	Baffle 4" Flue
8	Powered Anode
9	Baffle 2" Flue
10	Wire Harness-Service Panel
11	Plastisert Nipple 1 1/2" NPT
12	Plug
13	Nipple 3/4" NPT
14	T&P Relief Valve
15	Exhaust Pipe (PVC) w/ Barb Tap
16	Condensate Trap Elbow
17	Washers
18	Outer Door Service Panel
19	Service Panel Ass'y
20	Service Panel Bracket
21	Pressure Switch
22	Nuts
23	Collector Limit Switch
24	Screw 1/4 - 20 x 5/8 HWH
25	Cleanout Access
26	Cleanout Gasket
27	Screw 5/16 - 18 x 3/4 HH Grade 5
28	Cleanout Cover
29	Cold Water Inlet (Hydrojet) Ass'y
30	No Handle Brass Drain Valve
31	Vertical Coaxial Vent Terminal (optional)
32	Thermostatic Mixing Valve
33	Exhaust Limit Switch

Combustion Surround

1 Ass'y

AA	Keeper Latch & Catch
BB	Screw 8-32 x 1/2" RHCR
CC	Control Panel Assembly
DD	Jacket Head 28 1/4" Grey
EE	Switch Main Power
FF	Control Display
GG	Combustion Surround
JJ	Surround Bas/Jacket Head
KK	Display Harness

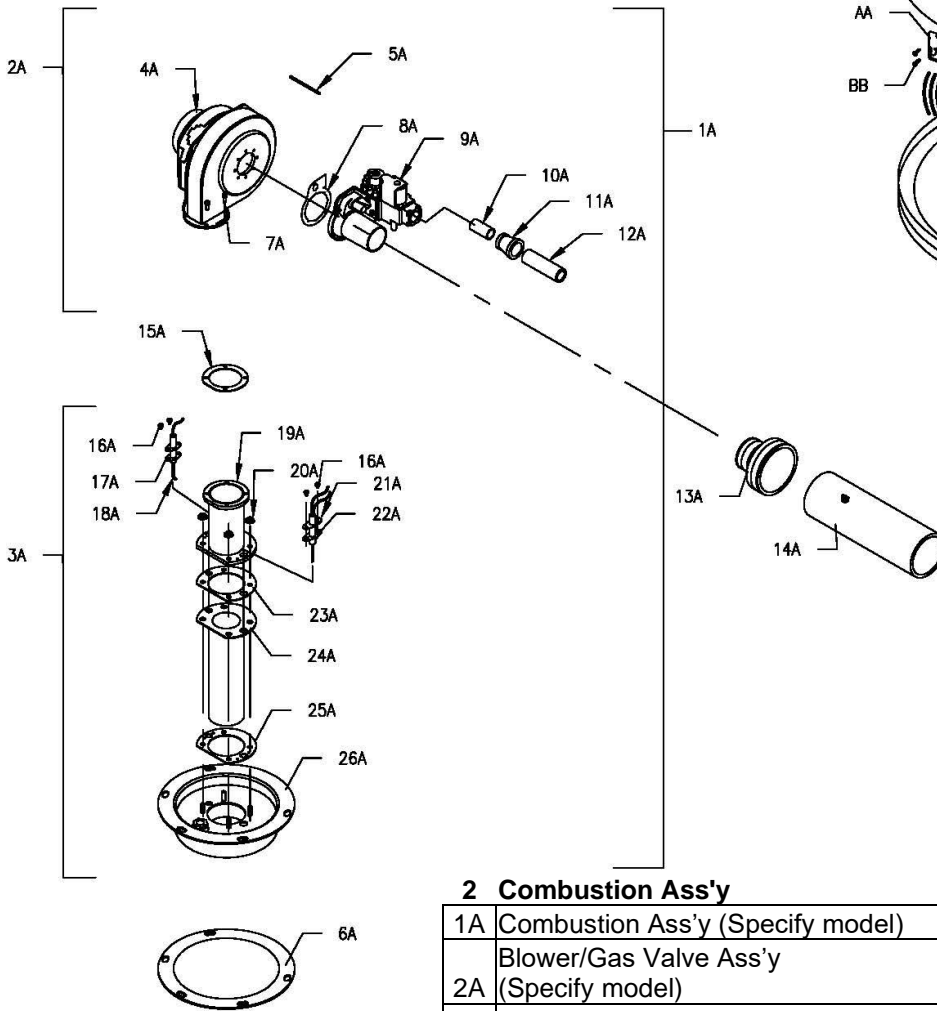
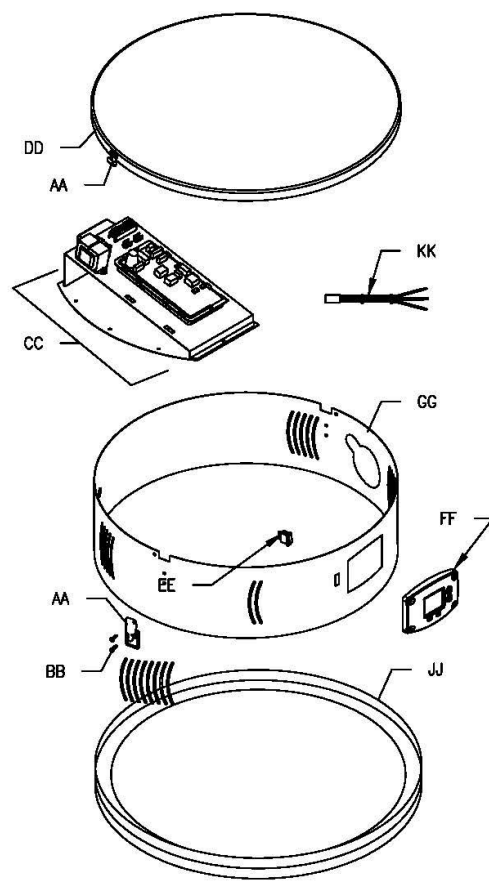

2 Combustion Ass'y

1A	Combustion Ass'y (Specify model)	14A	Inlet Pipe
2A	Blower/Gas Valve Ass'y (Specify model)	15A	Gasket Blower Transition (Specify model)
3A	Burner Ass'y (Specify model)	16A	Screw 8 -32 x 1/4" RHCR
4A	Blower – EBM (Specify model)	17A	Gasket Flame Sensor
5A	Silicone Hose	18A	Flame Sensor
6A	Burner Mounting Insert Gasket	19A	Transition Tube
7A	Screw 10-32 x 3/4" SHCS	20A	Nut Hex Washer
8A	Gasket & Screw	21A	Spark Rod Ignitor
9A	Gas Valve (Specify model)	22A	Spark Rod
10A	Nipple 1/2"NPT x 3"	23A	Burner Mounting Gasket
11A	Reducer 3/4" x 1/2" NPT	24A	Burner (Specific Model)
12A	Nipple 3/4" NPT x 7"	25A	Burner Mounting Gasket
13A	2" dia. Flex Reducer	26A	Burner Mounting Insert

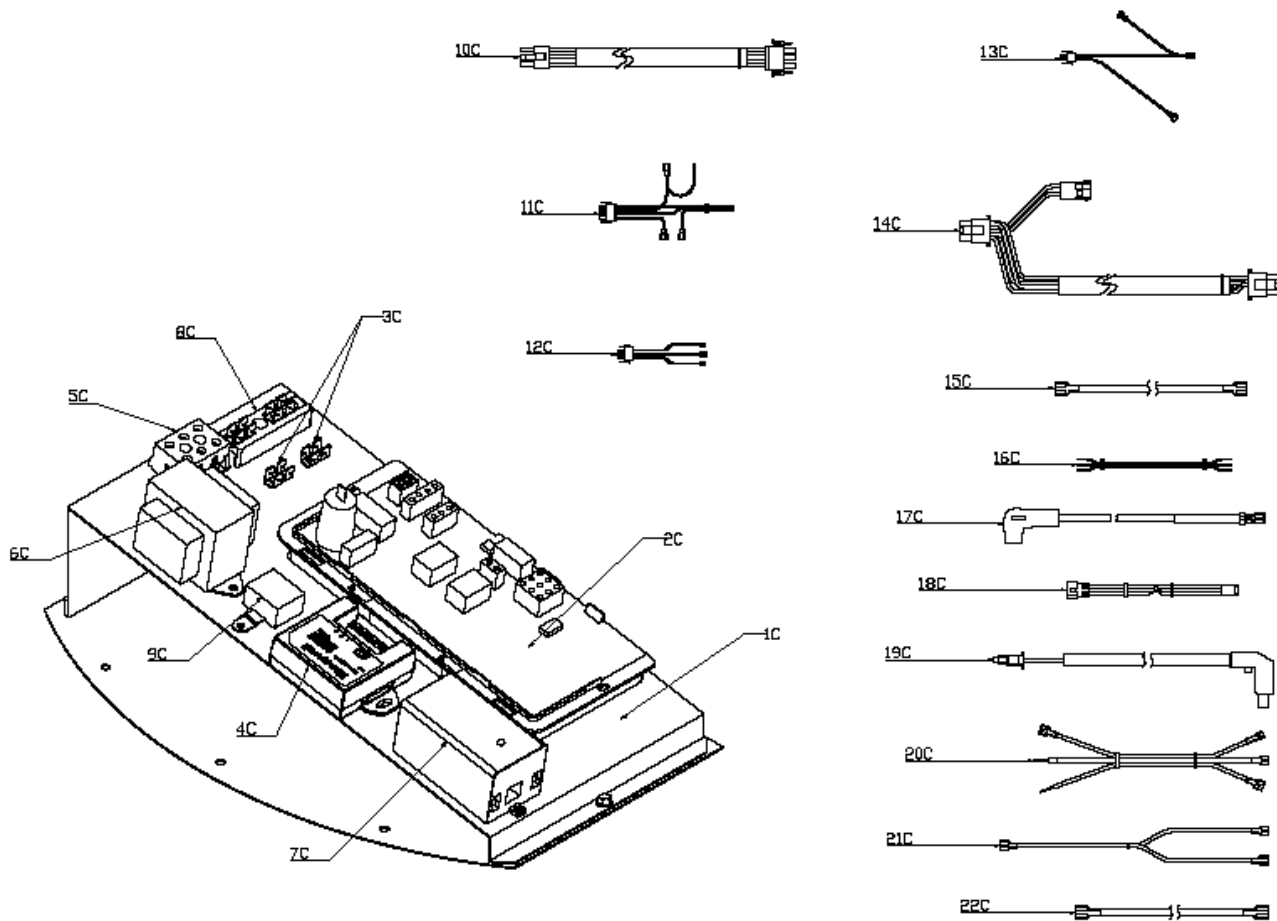

CC Ignition Control Assembly			
1C	Control Mounting Panel	12C	Transformer Harness
2C	Thermostat PC Board	13C	Transformer Harness (Secondary)
3C	Terminal	14C	Controller Harness
4C	Alarm Module	15C	Wire - Black
5C	Terminal Block	16C	Alarm Module Harness
6C	Transformer 240V	17C	Cable - High Voltage Spark
7C	Power Anode Control	18C	Display Harness
8C	Terminal Strip	19C	Gas Valve Rectifier Harness
9C	Noise Suppression Capacitor	20C	Powered Anode Control Harness
10C	Blower Harness	21C	Powered Anode Harness
11C	Power Switch Harness	22C	Wire - Blue

NOTES

NOTES
