

Installation and Operation Manual

Condensing Power (Direct) Vent Gas Water Heater

A Spanish language version of these instructions is available by contacting the manufacturer listed on the rating plate.

La versión española de estas instrucciones se puede obtener al escribirle a la fábrica cuyo nombre aparece in la placa de especificaciones.

⚠ WARNING

If the information in these instructions is not followed exactly, a fire or explosion may result in property damage, personal injury or death.

For Your Safety

Do not store or use gasoline or other flammable, combustible, or corrosive vapors and liquids in the vicinity of this or any other appliance.

WHAT TO DO IF YOU SMELL GAS:

- **DO NOT** try to light any appliance.
- **DO NOT** touch any electrical switch.
- **DO NOT** use any phone in your building.
- Immediately call your gas supplier from a neighbor's phone. Follow the gas supplier's instructions.
- If you cannot reach your gas supplier, call the fire department.

Installation and service must be performed by a qualified installer, service agency, or the gas supplier.

For your family's comfort, safety and convenience, it is recommended this water heater be installed and serviced by a plumbing professional.

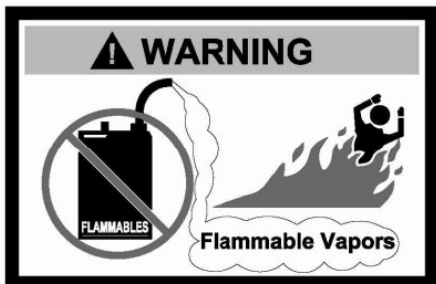

As required by the state of California Proposition 65.

CONGRATULATIONS!

You have purchased one of the finest water heaters on the market today!

This installation, operation and instruction manual will explain in detail the installation and maintenance of your new water heater. We strongly recommend that you contact a plumbing professional for the installation of this water heater.

We require that you carefully read this manual, as well as the enclosed warranty, and refer to it when questions arise. If you have any specific questions concerning your warranty, please consult the plumbing professional from whom your water heater was purchased. For your records we recommend that you write the model, serial number and installation date of your water heater in the maintenance section in the back of this manual.

This manual should be kept with the water heater.



Table of Contents

	Page
General Information	4
Installation	5
Locating the Water Heater	5
Minimum Clearances	7
Venting	7
Vent Pipe Preparation and Joining	28
Combustion Air Supply	29
Water Connections	31
Condensate Drain Connection	33
Gas Connections	34
Electrical Connections	35
Wiring Diagram	36
General Operation	37
Lighting and Shutdown Instructions	38
Thermostat Adjustment	39
Burner Flame Check	39
Maintenance	40
Troubleshooting	43
Parts Diagram	46
Installation Instructions For Potable Water & Space Heating	47

GENERAL INFORMATION

This gas-fired water heater is design certified by CSA International under the American National Standard Z21.10.3 and CAN/CGA 4.3-M most current editions at the time of manufacture. This is a category IV water heater.

This water heater must be installed in accordance with local codes or, in the absence of local codes, the National Fuel Gas Code, ANSI Z223.1-Latest Edition) and/or in Canada CAN/CGA B149 Installation Codes (Latest Editions). The warranty for this water heater is in effect only when the water heater is installed, adjusted, and operated in accordance with these Installation and Operation Instructions. The manufacturer will not be held liable for any damage resulting from alteration and/or failure to comply with these instructions.

This water heater is NOT design certified for installation in a mobile home. Such an installation may create a hazardous condition and will nullify the warranty.

CAUTION

Incorrect operation of this appliance may create a hazard to life and property and will nullify the warranty.

DO NOT use this appliance if any external part to the tank has been submerged in water. You should contact a qualified service technician to inspect the appliance and to replace any part of the control system including the gas control which has been submerged in water. See the Gas Connections section of this manual before servicing or replacing a water heater that has had any external part to the tank submerged in water.

DANGER

DO NOT store or use gasoline or other flammable, combustible, or corrosive vapors and liquids in the vicinity of this or any other appliance.

IMPORTANT

Before proceeding, please inspect the water heater and its components for possible damage. **DO NOT** install any water heater with damaged components. If damage is evident then please contact the supplier where the water heater was purchased, or the manufacturer listed on the rating plate for replacement parts.

Make sure that you check the rating plate and gas control on the water heater to be certain that the type of gas being supplied corresponds with the marking on the rating plate and gas control. Sacrificial anodes are used to extend tank life. Anode removal, except for inspection and/or replacement, will nullify the warranty. In areas where water is unusually active, an odor may occur at the hot water faucet due to a reaction between the sacrificial anodes and the impurities in the water. If this should happen, alternative anodes may be purchased from the supplier that installed this water heater. This will minimize the odor while protecting the tank. Additionally, the water heater should be flushed with appropriate dissolvers to eliminate any bacteria.

DANGER

This product contains one or more chemicals known to the State of California to cause cancer, birth defects, or reproductive harm.

INSTALLATION

Locating the Water Heater

⚠ WARNING

Water heaters are heat producing appliances. To avoid damage or injury, **DO NOT** store materials against the water heater or vent-air intake system. Use proper care to avoid unnecessary contact (especially by children) with the water heater and vent-air intake components. **UNDER NO CIRCUMSTANCES SHOULD FLAMMABLE MATERIALS, SUCH AS GASOLINE OR PAINT THINNER BE USED OR STORED IN THE VICINITY OF THIS WATER HEATER, VENT-AIR INTAKE SYSTEM OR IN ANY LOCATION FROM WHICH FUMES COULD REACH THE WATER HEATER OR VENT-AIR INTAKE SYSTEM.**

DO NOT install the water heater in any location where gasoline or flammable vapors are likely to be present.

Water heaters in residential garages must be installed so that all burner(s) and burner ignition device(s) are located not less than 18 in. (46 cm) above the floor and must be located or protected to avoid physical damage. For other installations refer to local codes. In the absence of local codes, the water heater must be installed in compliance with the National Fuel Gas Code, ANSI Z223.1 - (Latest Edition) and/or in Canada, CAN/CGA B149 Installation Codes (Latest Editions).

The location of this water heater is of the utmost importance. Before installing this water heater, read the installation section of these instructions. After reading these installation and operation instructions, select a location for the water heater where the floor is level and is easily accessible to gas and water supply lines.

DO NOT locate the water heater where water lines could be subjected to freezing temperatures. Make sure the cold water pipes are not located directly above the gas control so that condensate during humid weather does not drip on the controls.

Water heater corrosion and component failure can be caused by the heating and breakdown of airborne chemical vapors. Examples of some typical compounds that are potentially corrosive are: spray can propellants, cleaning solvents, refrigerator and air conditioning refrigerants, swimming pool chemicals, calcium and sodium chloride, waxes and process chemicals. These materials are corrosive at very low concentration levels with little or no odor to reveal their presence.

NOTE: Damage to the water heater caused by exposure to corrosive vapors is not covered by the warranty. DO NOT operate the water heater if exposure has or will occur. DO NOT store any potentially corrosive compounds in the vicinity of the water heater.

To comply with NSF requirements this water heater is to be:

- a. Sealed to the floor with sealant, in a smooth and easily cleanable way, or
- b. Installed with an optional leg kit that includes legs and/or extensions that provide a minimum clearance of 6" beneath the water heater.

Locating the Water Heater continued-

⚠ WARNING

Liquefied petroleum gases/propane gas are heavier than air and will remain at floor level if there is a leak. Basements, crawl spaces, closets, and areas below ground level will serve as pockets for accumulation of leaking gas. Before lighting, smell all around the appliance area for gas. Be sure to smell next to the floor.

IF YOU SMELL GAS:

- **DO NOT** try to light any appliance.
- **DO NOT** touch any electric switch; **DO NOT** use any telephone in your building.
- Immediately call your gas supplier from a neighbor's telephone. Follow the gas supplier's instructions.
- If you cannot reach your gas supplier, call the fire department.

DO NOT OPERATE APPLIANCE UNTIL THE LEAKAGE IS CORRECTED!

⚠ WARNING

DO NOT ATTEMPT TO LIGHT ANY GAS APPLIANCE IF YOU ARE NOT CERTAIN OF THE FOLLOWING:

- Liquefied petroleum gases/propane gas and natural gas have an odorant added by the gas supplier that aids in the detection of the gas.
- Most people recognize this odor as a "sulfur" or "rotten egg" smell.
- Other conditions, such as "odorant fade" can cause the odorant to diminish in intensity, or "fade", and not be as readily detectable.
- If you have a diminished sense of smell or are in any way unsure of the presence of gas, immediately contact your gas supplier from a neighbor's telephone.
- Gas detectors are available. Contact your gas supplier, or plumbing professional, for more information.

The water heater must be located close enough to the outside wall to keep the venting distance within the maximum distance described in the installation instructions. Locate the water heater as close as possible to the vent opening. Read the venting section in this instruction manual before locating the water heater.

This water heater must be located in an area where leakage of the tank, condensate trap, or water line connections and the combination temperature and pressure relief valve will not result in damage to the area adjacent to the water heater or to lower floors of the structure. Verify all condensate tubing is properly connected to the blower for proper drainage.

When such locations cannot be avoided, a suitable drain pan adequately piped for proper drainage must be installed under the water heater. The pan must not restrict combustion air flow. The drain pan must have a minimum length and width of at least 4 in. (10.2 cm) greater than the diameter of the water heater and must not restrict proper combustion air flow to the water heater. The drain pan, as described above, can be purchased from your plumbing professional. The drain pan must be piped to an adequate drain. The piping must be at least 3/4 in. (1.9 cm) in diameter and pitched for proper drainage.

It is recommended that a minimum clearance of 4 in. (10.2 cm) be provided on the side of the water heater for servicing and maintenance of the combination temperature and pressure relief valve.

Locating the Water Heater continued-

This water heater **MUST** be installed indoors out of the wind and weather.

Note: Per Section 507.2 Seismic Provisions of the 2021 Uniform Plumbing Code (UPC). Water heaters shall be anchored or strapped to resist horizontal displacement due to earthquake motion. Strapping shall be at points within the upper one-third and lower one-third of its vertical dimensions. At the lower point, a distance of not less than 4 inches shall be maintained from the controls with the strapping.

IMPORTANT

This water heater can be installed as either power direct vent or power vent (air from inside) system. If it is installed as a direct vent system, then the air intake and the exhaust vent are piped to the outside. If a power vented system is used, then air is drawn from inside and only the exhaust is piped to the outside. Horizontal and vertical venting can be mixed. Determine which system is best for your application and install as described in the following sections.

Minimum Clearances

⚠ WARNING

Failure to adhere to these installation and operation instructions may create a hazard to life and property and will nullify the warranty.

This installation must allow access to the front of the water heater and adequate clearance must be provided for servicing and operating this water heater. The water heater may be installed on either a combustible or non-combustible floor. If the water heater is to be installed directly on carpeting, it must be installed on top of a metal or wood panel extending beyond the full width and depth of the appliance by at least 3 in. (7.6 cm) in any direction or, if the appliance is to be installed in an alcove or closet, the entire floor must be covered by the panel. The minimum clearances to combustibles for this water heater are: 0 in. from the sides and rear, 5 in. (12.7 cm) from the front of the jacket, 0 in. from the vent connector and 15 in. (38.1 cm) from the jacket top. Increase distances to provide clearance for servicing.

Venting

The venting instructions must be followed to avoid restricted combustion or recirculation of flue gases. Such conditions cause sooting or risks of fire and asphyxiation. This water heater can be installed as either a power direct vent system or power vent (air from inside) system. If it is installed as a direct vent system, then the air intake and the exhaust vent are piped to the outside. If a power vented system is used, then air is drawn from inside and only the exhaust is piped to the outside. Determine which system is best for your application and install as described in the following sections.

Power Direct Vent Installation

Venting may be run horizontally through an outside wall or vertically through a roof through using either 2 in. (5.1 cm), 3 in. (7.7 cm), or 4 in. (10.2 cm) diameter pipe. This water heater is supplied with a screened intake elbow and exhaust coupling referred to as the air intake terminal and the exhaust vent terminal.

Venting continued-

Power Vent Installation

Power venting is where the indoor air is used, and the exhaust is vented to the outside. Venting may be run horizontally through an outside wall or vertically through a roof through using either 2 in (5.1 cm), 3 in (7.7 cm), or 4 in. (10.2 cm) diameter pipe.

WARNING

The vent system must be properly installed. Failure to properly install the vent system could result in property damage, personal injury, or death.

DO NOT install damaged venting system components. If damage is evident then contact the supplier where the water heater was purchased, or the manufacturer listed on the rating plate for replacement parts.

Use only the vent terminals provided or factory authorized terminals for venting this water heater.

The water heater requires its own separate venting system. **DO NOT** connect the exhaust vent into an existing vent pipe or chimney.

All of the exhaust venting connections must be leak checked with a soap solution upon initial start-up of the water heater. Any leaks must be repaired before continuing operation of the water heater.

DO NOT terminate the venting where noise from the exhaust or intake will be objectionable. This includes locations close to or across from windows and doors. Avoid anchoring the vent and intake pipes directly to framed walls, floors, or ceilings unless rubber isolation pipe hangers are used. This prevents any vibrations from being transmitted into the living spaces.

DO NOT exceed the venting distances or the number of elbows listed in this manual. Exceeding the maximum venting distances may cause the water heater to malfunction or cause an unsafe condition.

DO NOT operate this water heater until the venting installation is complete and the piping completed. Failure to complete installation before operation can result in property damage, personal injury, or death.

WARNING

Risk of carbon monoxide poisoning or fire due to joint separation or pipe breakage.

This water heater must be properly vented and connected to an approved vent system in good condition. **DO NOT** operate the water heater with the absence of an approved vent system. A clean and unobstructed vent system is necessary to allow noxious fumes that could cause injury or loss of life to vent safely and will contribute toward maintaining the water heater's efficiency. The acceptance of the venting system is dependent upon full compliance with these installation instructions. When an existing Category I appliance is removed or replaced, the original venting system may no longer be sized to properly vent the attached appliances.

For installations in Canada, the venting system must **NOT** pass through rated fire separations. The venting system must be free to expand and contract. This venting system **must be** supported in accordance with these instructions.

Venting continued-

IMPORTANT

For installations in Canada, field supplied vent piping must comply with CAN/CGA B149.1 (Latest Edition) and be certified to the Standard For Type BH, Class II, 65°C, Gas Venting Systems, ULC S636. Components of this listed system shall not be interchanged with other vent systems or un-listed pipe/fittings. All components and specified primers and cements of the certified vent system must be from a single system manufacturer and not intermixed with other system manufacturer's vent system parts. The supplied vent connector and vent termination are certified under ULC S636 and are also certified as part of the water heater. Refer to the following tables for approved venting materials, primers, and cements. All approved primers and cements are to be used within their marked time limitations.

Approved Venting Materials

For installations in the US only

- PVC DWV (ASTM D-2665)
- PVC Sch. 40, 80, 120 (ASTM-D1785)
- CPVC Sch. 40, 80 (ASTM-F441)
- CPVC (ASTM D2846)
- ABS Sch. 40 DWV (ASTM D2661)

For installations in CANADA

- ULC S636 approved PVC for flue gas venting rated Class II, 65°C
- ULC S636 approved CPVC for flue gas venting rated Class II, 65°C

Approved Primers and Cements

For installations in the US only

- PVC and CPVC Primer (ASTM-F656)
- PVC Cement (ASTM D-2564)
- CPVC Cement (ASTM F493)
- ABS Primer and Cement (ASTM D-2235)

For installations in CANADA

- ULC S636 approved Primer and Cement for flue gas venting rated Class II, 65°C

IMPORTANT

Use of cellular core PVC (ASTM F891), cellular core CPVC, or Radel® (polyphenosulfone) in non-metallic venting systems is prohibited and covering non-metallic venting with thermal insulation is prohibited.

IMPORTANT

Before beginning installation of any vent pipe, read the vent pipe manufacturer's installation instructions.

DO NOT install the water heater in any location where the ambient temperature may fall below freezing. Water heater must be protected from freezing downdrafts during shutdown periods. Provide protection of the building materials from degradation by flue gases from the exhaust vent terminal.

The vent shall terminate a minimum of 12 in. (30.5 cm) above expected snowfall level to prevent blockage of vent termination.

The horizontal centerline of the exhaust vent terminal (if applicable) must not be located lower than the horizontal centerline of the air intake terminal if vented through the same wall.

A service drain loop must be installed in the drain tubing to serve as a condensate trap to prevent flue gases from escaping into the room.

DO NOT position the air intake above the exhaust terminal.

NEVER locate the air intake where exhaust gases can be introduced.

Venting continued-

This water heater has a certified category IV, per latest ANSI Z 21.10.3-2015.CSA 4.3-2015 revision. Refer to the latest edition of the National Fuel Gas Code (ANSI Z223.1-latest edition), or in Canada, the Natural Gas and Propane installation Code (B149.1-00 latest edition).

Power Direct Vent Terminal Location

Plan the vent system layout so that proper clearances are maintained from plumbing and wiring. Before the vent is installed, determine the vent pipe termination location as shown in Figure 1.

Power Vent Terminal Location

Plan the vent system layout so that proper clearances are maintained from plumbing and wiring. Before the vent is installed, determine the vent pipe termination location as shown in Figure 2.

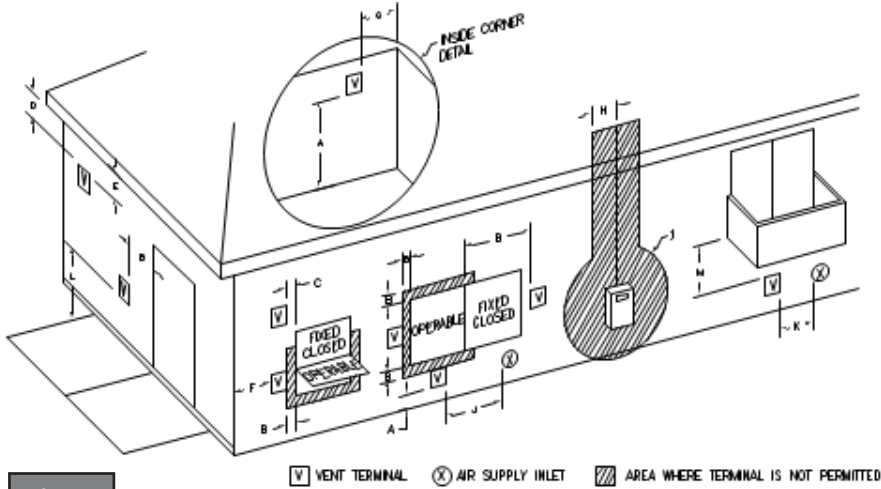

Fig. 1 Direct Vent and Powered Direct Vent Terminal Clearances

		Canadian Installations ¹	US Installations ²
A=	Clearance above grade, veranda, porch, deck or balcony	12 inches (30 cm)	12 inches (30 cm)
B=	Clearance to window or door that may be opened	6 in (15cm) for appliances ≤10,000 Btuh (3kW); 12 in (30 cm) for appliances >10,000 Btuh (3kW) and ≤100,000 Btuh (30kW); 36 in (91 cm) for appliances >100,000 Btuh (30 kW)	4 feet (1.2 m) below or to the side of opening; 12 inches (30 cm) above opening
C=	Clearance to permanently closed window	*b	*b
D=	Vertical clearance to ventilated soffit located above the terminal within a horizontal distance of 2 feet (61 cm) from the center line of the terminal	*b	*b

Venting continued-

		Canadian Installations ¹	US Installations ²
E=	Clearance to unventilated soffit	*b	*b
F=	Clearance to outside corner	*b	*b
G=	Clearance to inside corner	*b	*b
H=	Clearance to each side of center line extended above meter/regulator assembly	3 feet (91 cm) within a height 15 feet (4.6 m) above the meter/regulator assembly	*b
I=	Clearance to service regulator vent outlet or oil tank vent	36 inches (91 cm)	*b
J=	Clearance to non-mechanical air supply inlet to building or the combustion air inlet to any other appliance	6 in (15cm) for appliances ≤10,000 Btuh (3kW); 12 in (30 cm) for appliances >10,000 Btuh (3kW) and ≤100,000 Btuh (30kW); 36 in (91 cm) for appliances >100,000 Btuh (30 kW)	6 in (15 cm) for appliances ≤10,000 Btuh (3 kW); 9 in (23 cm) for appliances >10,000 Btuh (3 kW) and ≤ 50,000 Btuh (15 kW); 12 in (30 cm) for appliances >50,000 Btuh (15 kW)
K=	Clearance to a mechanical air supply inlet	6 feet (1.83 m)	3 feet (91 cm) above if within 10 feet horizontally
L=	Clearance above paved sidewalk or paved driveway located on public property	7 feet (2.13 m) †	7 feet (2.13 m) †
M=	Clearance under a veranda, porch, deck, or balcony	12 inches (30 cm) ‡	12 inches (30 cm) ‡

¹ In accordance with the current CAN/CGA-B149 Installation Codes.

² In accordance with the current ANSI Z223.1-(Latest Edition)/NFPA 54 National Fuel Gas Code.

† A vent shall not terminate directly above a sidewalk or paved driveway that is located between two single-family dwellings and serves both dwellings.

‡ Permitted only if a veranda, porch, deck or balcony is fully open on a minimum of two sides beneath the floor.

*a) A minimum clearance value determined by testing in accordance with section 2.20.

*b) "Clearance in accordance with local installation codes and the requirements of the gas supplier".

Venting continued-

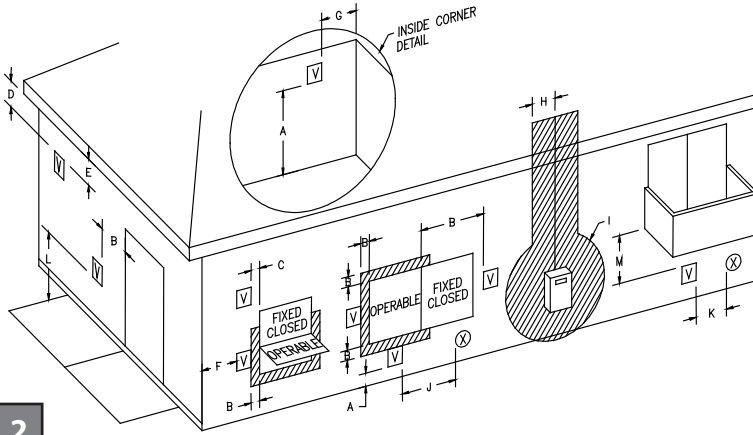

Fig. 2

V VENT TERMINAL
 X AIR SUPPLY INLET
 AREA WHERE TERMINAL IS NOT PERMITTED

Vent Terminal Clearances (Other than Direct Vent or Powered Direct Vent Installations)

		Canadian Installations ¹	US Installations ²
A=	Clearance above grade, veranda, porch, deck or balcony	12 inches (30 cm)	12 inches (30 cm)
B=	Clearance to window or door that may be opened	6 in (15cm) for appliances ≤10,000 Btuh (3kW); 12 in (30 cm) for appliances >10,000 Btuh (3kW) and ≤100,000 Btuh (30kW); 36 in (91 cm) for appliances >100,000 Btuh (30 kW)	4 feet (1.2 m) below or to the side of opening; 12 inches (30 cm) above opening
C=	Clearance to permanently closed window	*b	*b
D=	Vertical clearance to ventilated soffit located above the terminal within a horizontal distance of 2 feet (61 cm) from the center line of the terminal	*b	*b
E=	Clearance to unventilated soffit	*b	*b
F=	Clearance to outside corner	*b	*b
G=	Clearance to inside corner	*b	*b
H=	Clearance to each side of center line extended above meter/regulator assembly	*b	*b
I=	Clearance to service regulator vent outlet or oil tank vent	36 inches (91 cm)	*b

Venting continued-

		Canadian Installations ¹	US Installations ²
J=	Clearance to non-mechanical air supply inlet to building or the combustion air inlet to any other appliance	6 in (15cm) for appliances ≤10,000 Btuh (3kW); 12 in (30 cm) for appliances >10,000 Btuh (3kW) and ≤100,000 Btuh (30kW); 36 in (91 cm) for appliances >100,000 Btuh (30 kW)	4 feet (1.2m) below or to side of opening; 12 inches (30 cm) above opening.
K=	Clearance to a mechanical air supply inlet	6 feet (1.83 m)	3 feet (91 cm) above if within 10 feet horizontally
L=	Clearance above paved sidewalk or paved driveway located on public property	7 feet (2.13 m) †	7 feet (2.13 m) †
M=	Clearance under a veranda, porch, deck, or balcony	12 inches (30 cm) ‡	*b

¹ In accordance with the current CAN/CGA-B149 Installation Codes.

² In accordance with the current ANSI Z223.1-(Latest Edition)/NFPA 54 National Fuel Gas Code.

† A vent shall not terminate directly above a sidewalk or paved driveway that is located between two single-family dwellings and serves both dwellings.

‡ Permitted only if a veranda, porch, deck or balcony is fully open on a minimum of two sides beneath the floor.

*a) A minimum clearance value determined by testing in accordance with section 2.20.

*b) "Clearance in accordance with local installation codes and the requirements of the gas supplier".

The vent system must terminate so that proper clearances are maintained as cited in local codes or the Latest Edition of the National Fuel Gas Code, ANSI Z223.1.73.4e and 7.8a, b as follows:

1. Do not terminate near soffit vents or crawl space or other area where condensate or vapor could create a nuisance or hazard or cause property damage.
2. Do not terminate the exhaust vent terminal where condensate or vapor could cause damage or could be detrimental to the operation of regulators, relief valves, or other equipment.
3. Do not terminate the exhaust vent terminal over public area or walkways where condensate or vapor can cause nuisance or hazard.
4. The vent shall terminate a minimum of 12 inches (25.4 cm) above expected snowfall level to prevent blockage of vent termination.

Vent pipes serving power vent appliances are classified by building codes as "vent connectors". Required clearances from combustible materials must be provided in accordance with information in this manual under "Locating the Water Heater," "Minimum Clearances," and with the National Fuel Gas Code and local codes.

Clearance to combustibles for all venting pipes and terminals	
For installations in the US 0" minimum	For installations in Canada Refer to vent pipe and terminal manufacturer's installation instructions for clearances to combustibles.
DO NOT place insulation or other materials in the required clearance spaces between the venting to combustible material unless otherwise specified.	

Venting System Condensation

Condensate formation will occur in the venting of this condensing unit, whether as a power vent water heater or a power direct vent water heater. In order to effectively drain the condensate from the venting, tubing has been installed on a factory supplied exhaust adapter with drain outlet mounts on the blower. The tubing will drain any accumulated condensate from the venting system.

In a horizontal application, it is important that condensate not be allowed to buildup in the exhaust vent pipe. To prevent this from happening, the pipe should be installed with a slight upward slope of $\frac{1}{4}$ in./ft. (*.6 cm/.3 m*). The vent system must be supported every 5 ft. (*1.5 m*) of vertical run and every 5 ft. (*1.5 m*) of horizontal run of vent pipe length.

This water heater is a condensing power vented or power direct vented appliance and is designed to vent its products of combustion through 2 in. (*5.1 cm*), 3 in. (*7.6 cm*), or 4 in. (*10.2 cm*) diameter vent pipe to the outdoors. This water heater may be either vented horizontally through the wall or vertically through the roof. Use a 2 in. (*5.1 cm*) to 3 in. (*7.6 cm*) reducer to connect to the vent outlet when using 3 in. (*7.6 cm*) vent pipe or 2 in. (*5.1 cm*) to 4 in. (*10.2 cm*) reducer to connect to the vent outlet when using 4 in. (*10.2 cm*) vent pipe. Apply the proper cement at the joint locations.

Table 1 lists the maximum vent lengths for this water heater using 2 in. (*5.1 cm*) vent pipe. Locate the water heater so that the venting length and number of elbows are kept to the minimum distance necessary to reach the outside. If the installation requires venting lengths that exceed the lengths listed for 2 in. (*5.1 cm*) vent pipe in Table 1, then use 3 in. (*7.6 cm*) vent pipe for the vent connector or 4 in. (*10.2 cm*) as necessary.

Table 2 lists the venting distances allowed with 3 in. (*7.6 cm*) diameter vent pipe. When venting with 3 in. (*7.6 cm*) vent pipe, use a 3 in. (*7.6 cm*) to 2 in. (*5.1 cm*) reducer to exit through the building wall with 2 in. (*5.1 cm*) vent pipe. Use the 2 in. (*5.1 cm*) vent terminal supplied with the water heater to terminate on the outside of the building. If the length of 2 in. (*5.1 cm*) vent pipe needed to go through the wall is greater than 14 in. (*35.5 cm*), use 3 in. (*7.6 cm*) to go through the wall and reduce to 2 in. (*5.1 cm*) vent pipe immediately after exiting the outside wall. Refer to the venting illustrations on the following pages. Make sure the vent pipe terminal elbow fitting is at least 1 in. (*2.5 cm*) away from the edge of the wall.

Table 3 lists the venting distances allowed with 4 in. (*10.2 cm*) diameter vent pipe. When venting with 4 in. (*10.2 cm*) vent pipe, use a 4 in. (*10.2 cm*) to 2 in. (*5.1 cm*) reducer to exit through the building wall with 2 in. (*5.1 cm*) vent pipe. Use the 2 in. (*5.1 cm*) vent terminal supplied with the water heater to terminate on the outside of the building. If the length of 2 in. (*5.1 cm*) vent pipe needed to go through the wall is greater than 14 in. (*35.5 cm*), use 4 in. (*10.2 cm*) to go through the wall and reduce to 2 in. (*5.1 cm*) vent pipe immediately after exiting the outside wall. Refer to the venting illustrations on the following pages. Make sure the vent pipe terminal elbow fitting is at least 1 in. (*2.5 cm*) away from the edge of the wall.

Venting continued-

TABLE 1 – VENT CONNECTOR LENGTHS FOR 2" (5.1 cm) DIAMETER VENT PIPE

Terminating	# of 90° Elbows (excl. vent term)	Maximum straight Length ft (m)	Min. straight Length ft (m)
Through the Wall	1	45 (13.7)	2 (.6)
Through the Wall	2	40 (12.2)	2 (.6)
Through the Wall	3	35 (10.7)	2 (.6)
Through the Wall	4	30 (9.1)	2 (.6)
Through the Roof	0	50 (15.2)	7 (2.1)
Through the Roof	1	45 (13.7)	7 (2.1)
Through the Roof	2	40 (12.2)	7 (2.1)
Through the Roof	3	35 (10.7)	7 (2.1)
Through the Roof	4	30 (9.1)	7 (2.1)

TABLE 2 - VENT CONNECTOR LENGTHS FOR 3" (7.6 cm) DIAMETER VENT PIPE

Terminating	# of 90° Elbows (excl. vent term)	Maximum straight Length ft (m)	Min. straight Length ft (m)
Through the Wall	1	115 (35.0)	10 (3.1)
Through the Wall	2	110 (33.5)	10 (3.1)
Through the Wall	3	105 (32.0)	10 (3.1)
Through the Wall	4	100 (30.5)	10 (3.1)
Through the Wall	5	95 (29.0)	10 (3.1)
Through the Roof	0	120 (36.6)	15 (4.6)
Through the Roof	1	115 (35.0)	15 (4.6)
Through the Roof	2	110 (33.5)	15 (4.6)
Through the Roof	3	105 (32.0)	15 (4.6)
Through the Roof	4	100 (30.5)	15 (4.6)

TABLE 3 - VENT CONNECTOR LENGTHS FOR 4" (10.2 cm) DIAMETER VENT PIPE

Terminating	# of 90° Elbows (excl. vent term)	Maximum straight Length ft (m)	Min. straight Length ft (m)
Through the Wall	1	175 (53.3)	10 (3.1)
Through the Wall	2	170 (51.8)	10 (3.1)
Through the Wall	3	165 (50.3)	10 (3.1)
Through the Wall	4	160 (48.8)	10 (3.1)
Through the Wall	5	155 (47.2)	10 (3.1)
Through the Roof	0	180 (54.9)	15 (4.6)
Through the Roof	1	175 (53.3)	15 (4.6)
Through the Roof	2	170 (51.8)	15 (4.6)
Through the Roof	3	165 (50.3)	15 (4.6)
Through the Roof	4	160 (48.8)	15 (4.6)

Venting continued-

NOTE: When using 3" (7.6 cm) or 4" (10.2 cm) vent pipe, use a reducer to 2" (5.1 cm) and exit the building wall with 2" (5.1 cm) vent pipe using the 2" (5.1 cm) 45° vent terminal supplied. Two 45° elbows are equivalent to one 90° elbow. Each 90° elbow is equivalent to 5 feet (1.5 m) of straight vent pipe.

IMPORTANT

The air intake and exhaust terminals may be located on separate outside walls or one terminal may exit the roof while the other is through the wall. The total combined equivalent vent length must be within the limits specified in the venting tables and the intake length cannot exceed the exhaust by more than 30 ft. (9.2 m).

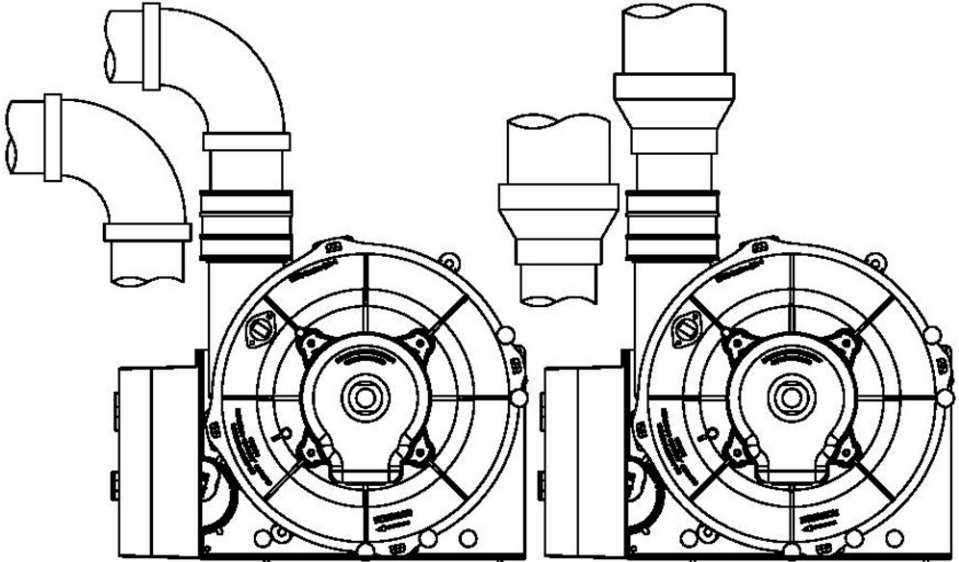

Fig. 3 Vent Connections

NOTE: When connection is made to a 3 in. (7.6 cm) or a 4 in. (10.2 cm) vent pipe, the reducer must be applied to the 2 in. (5.1 cm) pipe attached to the blower exhaust as shown.

IMPORTANT

All venting connections must be leak checked with a soap and water solution upon initial startup of the water heater. Any leaks must be repaired before continuing operation of the water heater.

Venting continued- Power Direct Vent

Through the Wall Venting (Horizontal Venting With Standard Vent Terminals):

Cut two 2 1/2 in. (6.4 cm) diameter holes in the wall at the point where the vent connector is going to pass through the wall. Use the proper cement to secure the 45° vent terminal provided with the water heater to the vent connector. The distance between the edges of the 45° vent terminal and the exterior wall must be 1 in. (2.5 cm) (see Figure 4). The exhaust and intake must not be less than 16 in. (40.6 cm) apart, and the exhaust terminal must be a minimum of 2 in. (5.1 cm) higher than the intake terminal (see Figure 5). Use the proper cement and assembly procedures to secure the vent connector joints between the terminal and the blower outlet. Provide support brackets for every 5 ft. (1.5 m) of horizontal vent.

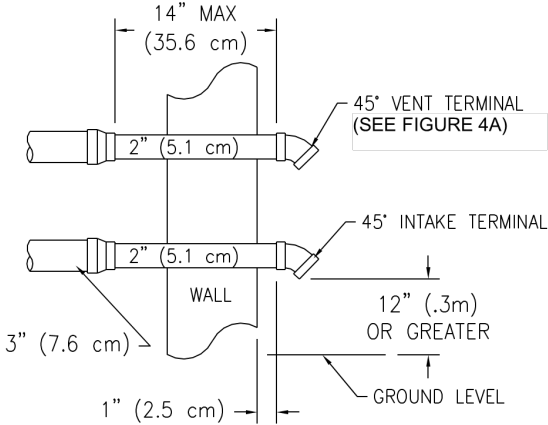

2" VENT INSTALLATION

Fig. 4

Vent Installations

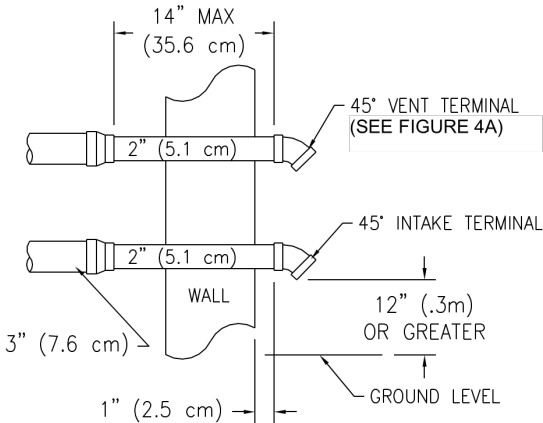

3" VENT INSTALLATION

Venting continued-

Vent Terminal Configurations For Through The Wall Venting:

When venting through the wall, the exhaust terminal must exit the structure at a minimum distance of 16 in. (40.6 cm) from the intake terminal. The exhaust terminal must not be located below the intake terminal for any reason (see Figure 6 for examples of acceptable vent terminal configurations).

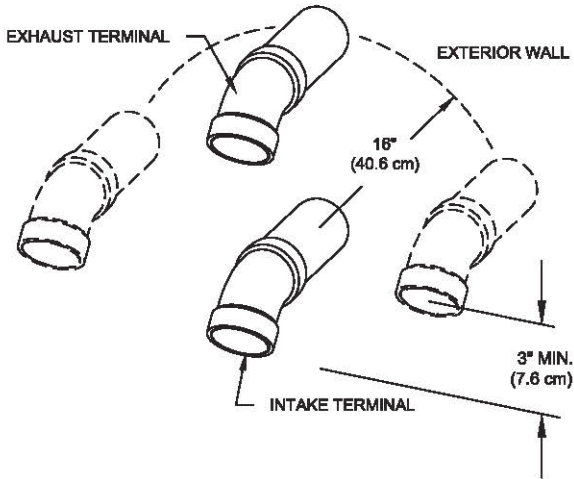

Fig. 5

CAUTION

NEVER INSTALL AIR INTAKE ABOVE EXHAUST

When local conditions present a risk of ice accumulation on the vent terminals, the configurations in Figures 5 and 6 or the concentric termination are preferred.

The air intake screen can be removed for cold installations, but this may make the air intake susceptible to debris buildup from birds or other animals. If the air intake screen is removed to prevent freezing, then it is recommended that the air inlet screen be installed during the spring.

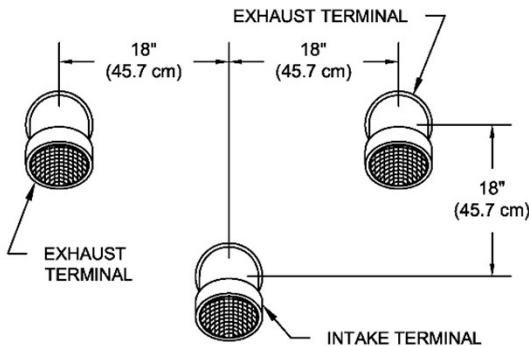
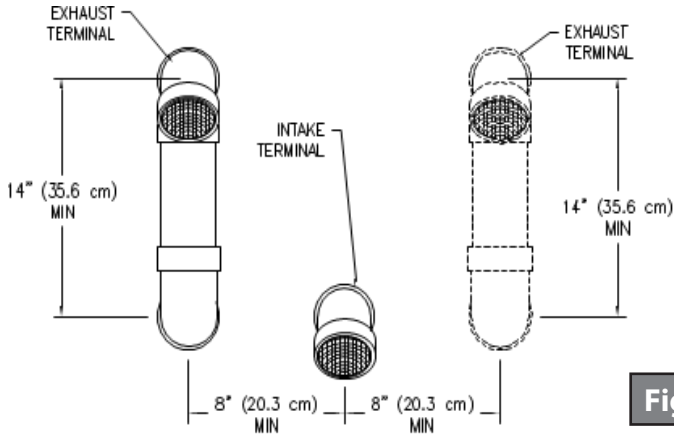

Fig. 6

Venting continued-



IMPORTANT

When using the vent terminal configuration shown in Figure 7 the extra elbows must be accounted for in the total vent length see Table 5, Table 6 or Table 7.

Through the Wall Venting (Horizontal Venting With Concentric Vent):

Cut one 3 5/8 in. (11.7 cm) diameter hole in the wall at the point where the vent connector is going to pass through the wall. Use the proper cement to secure the vent terminal to the vent connector. Use the proper cement and assembly procedures to secure the vent connector joints between the terminal and the blower outlet. Provide support brackets for every 5 ft. (1.5 m) of horizontal vent.

IMPORTANT

When using the concentric vent terminal, the maximum vent length is reduced by 10 ft. (3.1 m).

Fig. 8

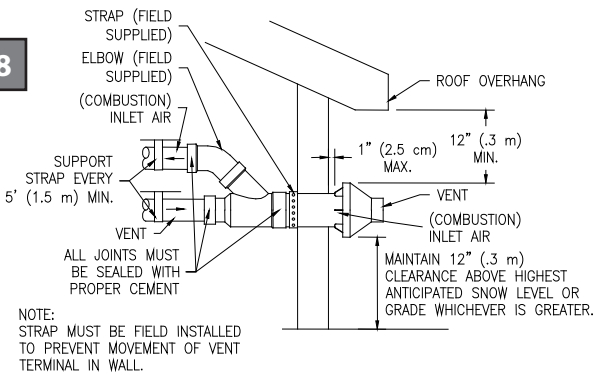

Venting continued-

It is acceptable to install a 90° elbow on IPEX concentric vent terminations use with this power direct vent water heater (see Figure 9). A short length of appropriate diameter vent pipe should be used to transition from the vent terminal to the 90° elbow. Approved venting materials along with primers and cements are listed at the beginning of this venting section. When the 90° elbow is used the equivalent length of the elbow and short length of vent pipe must be factored into the total vent/air intake pipe determinations (see Tables 4 and 5 for appropriate vent connector lengths).

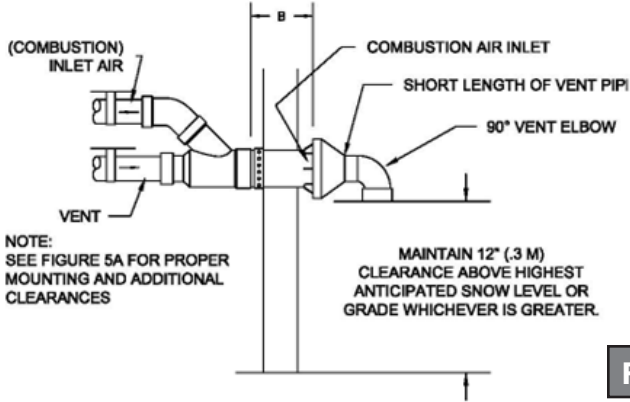

Fig. 9

(B) DIMENSION	
MIN	MAX
12 IN (30.5 CM)	44 IN (111.8 CM)

Low Profile Side Wall Termination Kit

The IPEX Low Profile side wall termination kits are fully certified for use with IPEX product only. IPEX System 636 PVC Low Profile vent kits are made from certified compound and IPEX System 1738 PVC Low Profile vent kits are made from a UL1738 certified PVC compound. Both are rated to a maximum temperature of 149°F (65°C).

Each kit contains: 1 Base (two holes), 1 Cap (one hole), 8 Stainless Steel Screws, and 4 Plastic Anchors.

IMPORTANT

The vent termination **must** maintain all termination clearances and be installed in accordance with local building codes and/or The National Fuel Gas Code ANSI Z223.1 (Latest Edition) or CGA/CAN B149 Installation Code.

⚠ WARNING

When locating the penetration of the vent and air pipe, ensure the termination is properly oriented as shown in Figure 11 and ensure that it maintains minimum clearance requirements as shown in Figure 10. For multiple vent terminations, ensure that a minimum clearance of 12 in (30 cm) is maintained between edge of air inlet and adjacent vent outlet and that all vent pipes and air inlets terminate at the same height to avoid the recirculation of flue gases and the possibility of causing severe personal injury, death, or substantial property damage (see Figure 11).

Venting continued-

⚠ CAUTION

When installing the vent termination in a vertical configuration, ensure the vent piping is located above the air inlet piping. This will avoid the risk of flue gas products recirculating into the air inlet and building.

Table 4 – Approved 3” & 4” Low-Profile Terminals

Terminal Description	Bradford White Part Number	Pipe O.D.	Hole Spacing (ctr to ctr)	IPEX System	IPEX Part Number
2” Low Profile	---	2.375”	5.6”	636	196984
2” Low Profile	---	2.375”	5.6”	1738	397984
3” Low Profile	---	3.5”	5.6”	636	196985
3” Low Profile	---	3.5”	5.6”	1738	397985
4” Low Profile	---	4.5”	5.6”	636	196986
4” Low Profile	---	4.5”	5.6”	1738	397086

Installation Procedure

1. Once the proper location has been determined, cut 2 holes in the wall large enough to accommodate the pipe. Pipe diameters and distance between hole centers can be found in Table 4.
2. Slide both the intake and vent pipe through the holes. Solvent weld both pipes to the base of the vent termination kit (see Figure 10).
3. To fasten the base to the wall, use the supplied screws and anchors. A 3/16 in (5 mm) diameter, 1/16-3/16 in (30 mm) deep hole will need to be drilled for the anchors. Locate the anchor hole by using the base as a template and then drill the required holes.
4. Screw the cap to the base using the supplied screws.
5. Once the vent termination and pipes are secured, the wall penetrations will need to be sealed from the interior using a PVC compatible material.

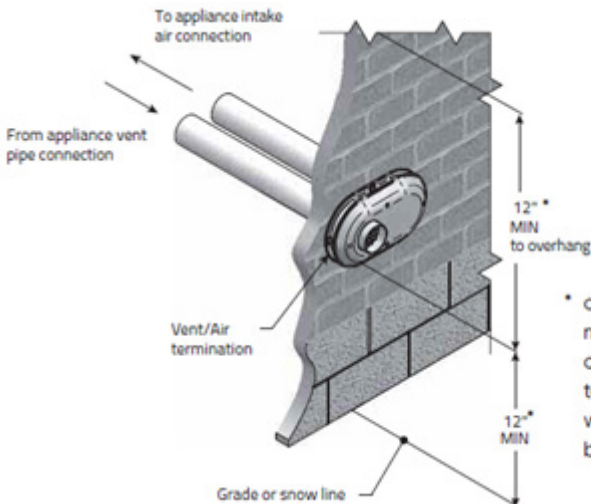

Fig. 10

Typical Side Wall Termination

Venting continued-



Fig. 11 Approved Installation Orientation

Fig. 12

Side Wall Termination Assembly

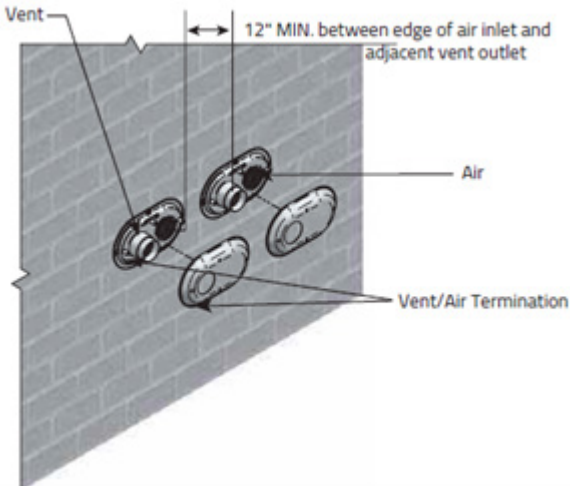
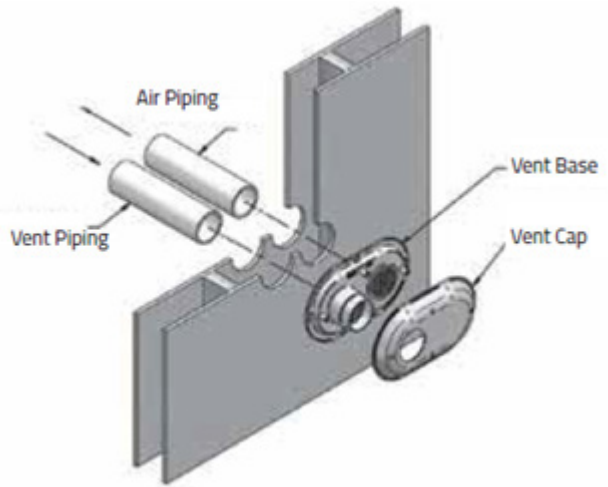

Fig. 13

Minimum Clearances: Multiple Side Wall Terminations

Venting continued-

Through the Roof Venting (Vertical Venting Standard Terminals):

Cut the necessary holes through the roof and ceiling and install the vent connector as shown in Figure 14. Make sure that the installation meets the local codes and/or The National Fuel Gas Code ANSI Z223.1 (Latest Edition) or CGA/CAN B149 Installation Code (latest edition).

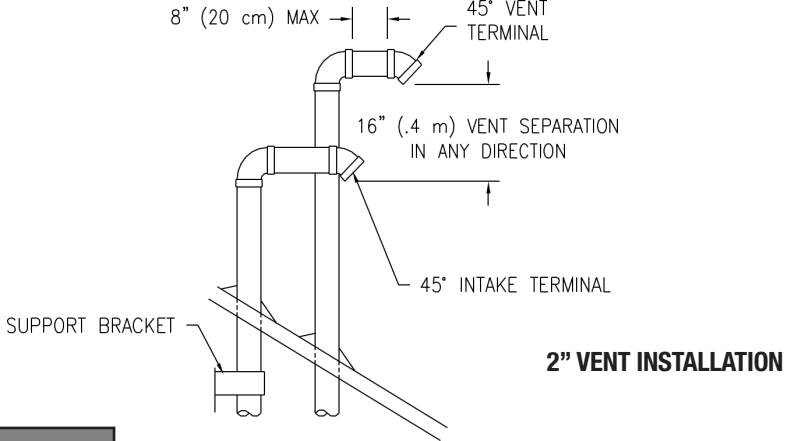
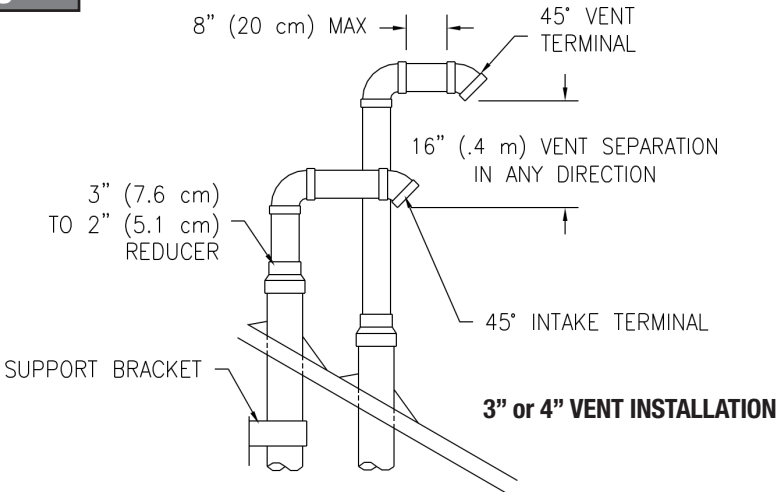

Fig. 14



NOTE: For installations requiring both horizontal and vertical runs, the following rule must be followed: **Total length of straight pipe (both horizontally and vertically) must not exceed the maximum equivalent length listed in these instructions.**

Venting continued-

Through the Roof Venting (Vertical Venting Concentric Vent Terminal):

Cut the necessary holes through the roof and ceiling and install the vent connector as shown in Figure 15. Make sure that the installation meets the local codes and/or the National Fuel Gas Code ANSI Z223.1 (Latest Edition) or CAN/CGA B149 installation code (latest edition).

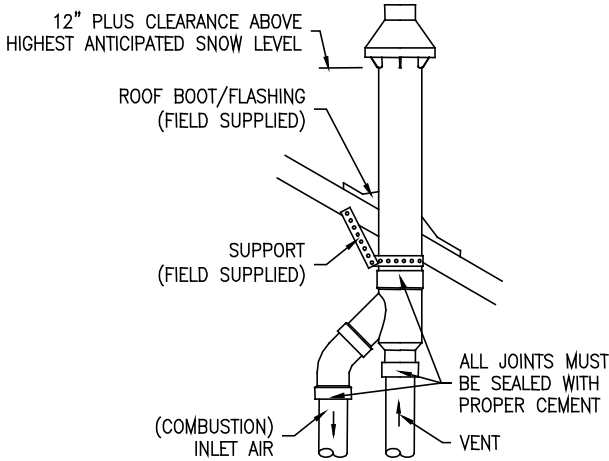

Fig. 15

NOTE: For installations requiring both horizontal and vertical runs, the following rule must be followed: Total length of straight pipe (both horizontally and vertically) must not exceed the equivalent length listed in these instructions. For the concentric vent terminal, the maximum vent length is reduced by 10 ft. (3.1 m).

Power Vent Installation

Power venting is where the indoor air is used, and the exhaust is vented to the outside. Venting may be run horizontally through an outside wall or vertically through a roof through using either 2 in. (5.1 cm), 3 in. (7.7 cm), or 4 in. (10.2 cm) diameter pipe.

When using this model as a power vent type (drawing intake air from indoors), it is still required to have at least the minimum vent length on your intake assembly. The equivalent length of intake venting must be within 30 ft (9.2 m) of the equivalent exhaust length.

Through the Wall Venting (Horizontal Venting):

Cut a 2 1/2 in. (8.9 cm) diameter hole in the wall at the point where the vent connector is going to pass through the wall. Use the proper cement to secure the 90° vent terminal provided with the water heater to the vent connector. The distance between the edges of the 90° vent terminal and the exterior wall (see Figure 16) must be 1 in. (2.5 cm). Use the proper cement and assembly procedures to secure the vent connector joints between the terminal and the blower outlet. Provide support brackets for every 5 ft. (1.5 m) of horizontal vent.

Venting continued-

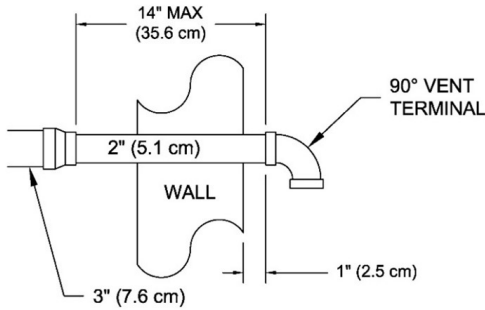
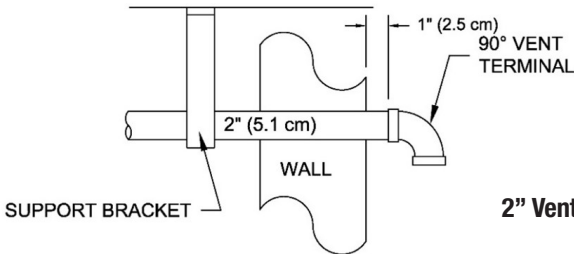

Fig. 16

3" or 4" Vent Installation



2" Vent Installation

Through the Roof Venting (Vertical Venting):

Cut the necessary holes through the roof and ceiling and install the vent connector as shown in Figure 17. Make sure that the installation meets the local codes and/or The National Fuel Gas Code ANSI Z223.1 (Latest Edition) or CGA/CAN B149 Installation Code (Latest Edition).

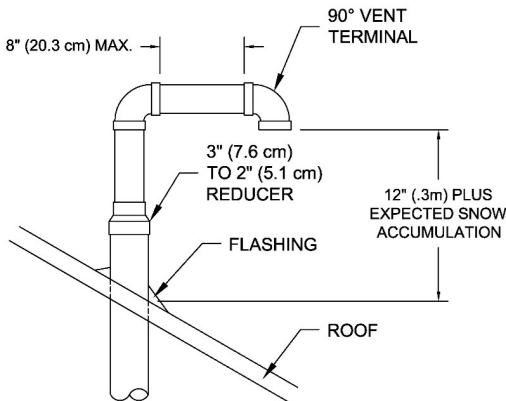

Fig. 17

NOTE: For installations requiring both horizontal and vertical runs, the following rule must be followed: Total length of straight pipe (both horizontally and vertically) must not exceed the allowable length listed in Table 5, Table 6 or Table 7 for the total number of elbows used.

Venting continued-

Through the Wall Venting With Low Ground Clearance:

When venting cannot exit through the wall at a height greater than or equal to 12 in. (30.5 cm) above the ground, or anticipated snow level, the installation must be modified as shown below (see Figure 18). Refer to Table 5 for maximum venting lengths using 2 in. (5.1 cm) vent pipe, Table 6 for maximum lengths using 3 in. (7.6 cm) vent pipe or Table 7 for maximum lengths using 4 in. (10.2 cm) vent pipe.

Power Vent Low Clearance Installation

2" Vent Installation

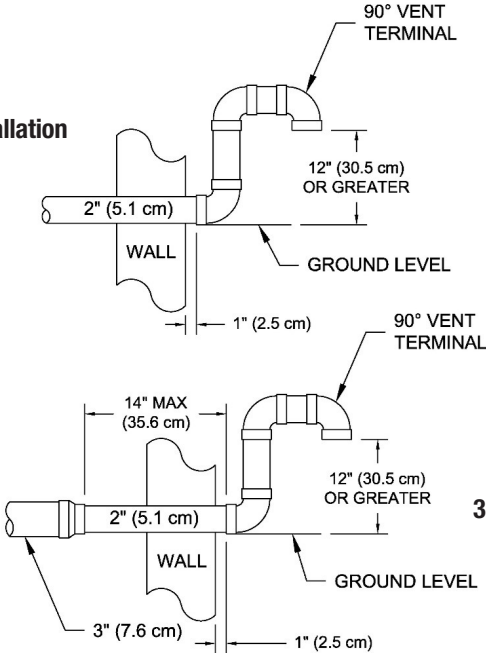

Fig. 18

3" or 4" Vent Installation

NOTE: For installations requiring both horizontal and vertical runs, the following rule must be followed: **Total length of straight pipe (both horizontally and vertically) must not exceed the allowable length listed in Table 5, Table 6 or Table 7 for total number of elbows used.**

Venting continued- Power Direct Vent Low Clearance Installation

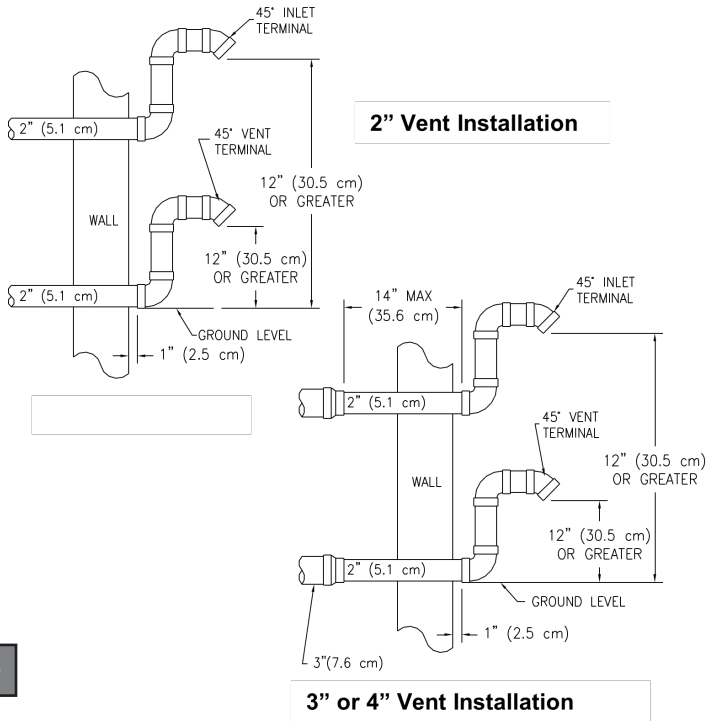

Fig. 19

NOTE: For installations requiring both horizontal and vertical runs, the following rule must be followed: Total length of straight pipe (both horizontally and vertically) must not exceed the allowable length listed in Table 5, Table 6 or Table 7 for total number of elbows used.

Table 5 - 2" (5.1 cm) Vent Connector Lengths From Inside Wall For Low Ground Clearance Installations

Terminating	# of Elbows (excl. vent term.)	Max Straight Length ft (m)	Min Straight Length ft (m)
(2) 90° Elbows with Vent Terminal	1	30 (9.1)	5 (1.5)
(2) 90° Elbows with Vent Terminal	2	25 (7.6)	5 (1.5)
(2) 90° Elbows with Vent Terminal	3	20 (6.1)	5 (1.5)
(2) 90° Elbows with Vent Terminal	4	15 (4.6)	5 (1.5)

Venting continued-

Terminating (Reduce 3" to 2") (Reduce 7.6 cm to 5.1 cm)	# of Elbows (excl. vent term.)	Max Straight Length ft (m)	Min Straight Length ft (m)
(2) 90° Elbows with Vent Terminal	1	100 (30.5)	10 (3.1)
(2) 90° Elbows with Vent Terminal	2	95 (29.0)	10 (3.1)
(2) 90° Elbows with Vent Terminal	3	90 (27.4)	10 (3.1)
(2) 90° Elbows with Vent Terminal	4	85 (25.9)	10 (3.1)
(2) 90° Elbows with Vent Terminal	5	80 (24.4)	10 (3.1)

Terminating (Reduce 4" to 2") (Reduce 10.2 cm to 5.1 cm)	# of Elbows (excl. vent term.)	Max Straight Length ft (m)	Min Straight Length ft (m)
(2) 90° Elbows with Vent Terminal	1	160 (48.8)	10 (3.1)
(2) 90° Elbows with Vent Terminal	2	155 (47.2)	10 (3.1)
(2) 90° Elbows with Vent Terminal	3	150 (45.7)	10 (3.1)
(2) 90° Elbows with Vent Terminal	4	145 (44.2)	10 (3.1)
(2) 90° Elbows with Vent Terminal	5	140 (42.7)	10 (3.1)

HIGH ALTITUDE INSTALLATIONS FOR ELEVATIONS OVER 2,000 FEET (762 m) ABOVE SEA LEVEL

The capacity of the induced draft blower declines with increasing altitude due to a reduction in the air density. In order to assure safe and reliable performance of the water heater, contact the supplier for a high-altitude kit.

PV/PDV Vent Pipe Preparation and Joining

Most failures in vent systems result from improper preparation and joining of pipe and fittings. The guidelines below must be followed when installing the venting system. If you have any question about the application or installation of the venting system, contact the vent pipe manufacturer, supplier, or your plumbing professional.

1. Specific cleaners, solvents, primers and cements are available for PVC, CPVC, and ABS pipe. Be sure these materials match the type of pipe to be installed. The vent pipe manufacturers joining instructions must be followed in all cases. Never use all-purpose cements, commercial glues and adhesives or ABS cement to join PVC or CPVC pipe and fittings. Refer to the table at the beginning of the "Venting" section for approved primers and cements.
 - a. **CLEANERS, SOLVENTS, PRIMERS AND CEMENTS ARE FLAMMABLE. DO NOT store or use these materials near heat or open flame, or in the vicinity of other appliances.**

PV/PDV Vent Pipe Preparation and Joining continued-

2. Use proper cutting, deburring and applicator tools to ensure proper preparation and joining of pipe and fittings.
 - a. Cutting Tools
 - i. A square cut must be achieved with a miter box saw or pipe cutter to ensure a proper mating with the female. If a pipe cutter is used, the burr created at the outer edge of the pipe must be removed.
 - b. Deburring Tools
 - i. A file, knife or plastic deburring tool can be used to remove burrs. Burrs must be removed from the inside and outside edges of the pipe to ensure a proper seal.
 - c. Applicator Tools
 - i. A natural bristle paintbrush or roller may be used to apply cement. Prompt application of the cement is important due its fast-drying properties.
3. Inspection, Cleaning, Priming and Cementing
 - a. Inspect the pipe inside and out for dirt, dust, moisture, or grease etc. Check pipe and fittings for splits or cracks and replace if found.
 - b. Clean pipe and fittings are imperative for proper joining. Following cutting and deburring, wipe away any foreign material with a clean dry rag. If wiping fails to thoroughly clean surfaces, chemical cleaning is necessary.
 - c. Primer must be applied to the pipe surface and fitting socket with a natural bristle brush. This serves to soften and prepare the pipe for cementing.
 - d. Cementing must be done quickly to avoid over-drying before joining.
 - i. Apply one coat to the outside end of the pipe at a width slightly greater than the depth of the socket.
 - ii. Apply a coat around the inside of the fitting socket.
 - iii. Apply a second coat around the end of the pipe.
4. Joining
 - a. Joints should be made immediately after cement is applied.
 - b. After fully inserting pipe into fitting socket, hold joint together for about 15 to 20 seconds.
 - c. Remove excess cement from around pipe and fitting with a clean rag.
 - d. Cement drying times may vary. Be sure to allow for the recommended drying time before disturbing joints.

For more specific and detailed information about the above, contact the vent pipe manufacturer, supplier, or competent professional.

Combustion Air Supply

WARNING

Liquefied petroleum gas/propane gas is heavier than air and will remain at floor level if there is a leak. Basements, crawl spaces, closets and areas below ground level will serve as pockets for accumulation of leaking gas. Before lighting, smell all around the appliance area for gas. Be sure to smell next to the floor.

IF YOU SMELL GAS:

- **DO NOT** try to light any appliance.
- **DO NOT** touch any electric switch; **DO NOT** use any telephone in your building.
- Immediately call your gas supplier from a neighbor's telephone. Follow the gas supplier's instructions.
- If you cannot reach your gas supplier, call the fire department.

DO NOT OPERATE APPLIANCE UNTIL LEAKAGE IS CORRECTED!

Combustion Air Supply continued-

IMPORTANT

The flow of combustion and ventilating air must not be obstructed

Provide adequate air for combustion and ventilation. An insufficient supply of air will cause recirculation of combustion products resulting in air contamination that may be hazardous to life. Such a condition often will result in a yellow, luminous burner flame, causing carbon build up or sooting of the combustion chamber, burners, and flue tubes with possible damage to the water heater.

When an exhaust fan is installed in the same room with a water heater, sufficient openings for air must be provided in the walls. Undersized openings will cause air to be drawn into the room through the venting, causing recirculation of combustion products.

Unconfined Spaces

In unconfined spaces in buildings, infiltration may be adequate to provide air for combustion, ventilation, and dilution of flue gases. However, in buildings of tight construction (for example: weather stripping, heavily insulated, caulked, vapor barrier, etc.), additional air may need to be provided using the methods described under Confined Spaces: All Air from Outdoors or Specially Engineered Installations.

Confined Spaces

Confined spaces are spaces defined as having less than 50 ft.³/1000 BTU (*1.4 m³/0.29 kw-hr*).

All Air From Inside the Building

The confined space must be provided with two permanent openings communicating directly with an additional room(s) of sufficient volume so that the combined volume of all spaces meets the criteria for an unconfined space. The total input of all gas utilization equipment installed in the combined space must be considered in making this determination. Each opening must have a minimum free area of 1 in.²/1000 BTU (*6.5 cm²/0.29 kw*) per hour of the total input rating of all gas utilization equipment in the confined space, but not less than 100 in.² (*645 cm²*). One opening must be within 12 in. (*31 cm*) of the top and one within 12 in. (*31 cm*) of the bottom of the enclosure.

All Air From Outdoors

The confined space must be provided with two permanent openings, one commencing within 12 in. (*31 cm*) of the top and one commencing within 12 in. (*31 cm*) from the bottom of the enclosure. The openings must communicate directly, or by ducts, with the outdoors or spaces (crawl or attic) that freely communicate with the outdoors.

1. When directly communicating with the outdoors, each opening must have a minimum free area of 1 in.²/4000 BTU (*6.5 cm²/1.2 kw*) per hour of total input rating of all equipment in the enclosure.
2. When communicating with the outdoors through vertical ducts, each opening must have a minimum free area of 1 in.² (*6.5 cm²*) per 4000 BTU (*1.2 kw*) per hour of total input rating of all equipment in the enclosure.
3. When communicating with the outdoors through horizontal ducts, each opening must have a minimum free area of 1 in.²/2000 BTU (*6.5 cm²/0.6 kw*) per hour of total input rating of all equipment in the enclosure.
4. When ducts are used, they must be of the same cross-sectional area as the free area of the openings to which they connect. The minimum dimension of rectangular air ducts must be not less than 3 in. (*7.5 cm*).

Combustion Air Supply continued-

Specialty Engineered Installations

The requirements noted in the Confined Spaces section addressed previously does not necessarily govern when special engineering, approved by the authority having jurisdiction, provides an adequate supply of air for combustion, ventilation, and dilution of flue gases.

Water Connections

NOTE: BEFORE PROCEEDING WITH THE INSTALLATION, CLOSE THE MAIN WATER SUPPLY VALVE.

After shutting off the main water supply, open a faucet to relieve the water line pressure to prevent any water from leaking out of the pipes while making the water connections to the water heater. After the pressure has been relieved, close the faucet. The COLD water inlet and HOT water outlet are identified on the top of the water heater. The fittings at the cold water inlet and hot water outlet are dielectric waterway fittings with $\frac{3}{4}$ " NPT male thread. Make the proper plumbing connections between the water heater and the plumbing system to the house. Install a shut-off valve in the cold water supply line.

CAUTION

If sweat fittings are to be used, **DO NOT** apply heat to the nipples on top of the water heater. Sweat the tubing to the adapter before fitting the adapter to the water connections. It is imperative that heat is not applied to the nipples containing a plastic liner.

If this water heater is installed in a closed water supply system, such as one having a back-flow preventer in the cold water supply, provisions must be made to control thermal expansion. **DO NOT** operate this water heater in a closed system without provisions for controlling thermal expansion. Your water supplier or local plumbing inspector should be contacted on how to control this situation.

WARNING

FAILURE TO INSTALL AND MAINTAIN A NEW, LISTED $\frac{3}{4}$ " X $\frac{3}{4}$ " TEMPERATURE AND PRESSURE RELIEF VALVE WILL RELEASE THE MANUFACTURER FROM ANY CLAIM THAT MIGHT RESULT FROM EXCESSIVE TEMPERATURE AND PRESSURES.

After installation of the water lines, open the main water supply valve and fill the water heater. While the water heater is filling, open several hot water faucets to allow air to escape from the water system. When a steady stream of water flows through the faucets, close them and check all water connections for possible leaks. **NEVER OPERATE THE WATER HEATER WITHOUT FIRST BEING CERTAIN IT IS FILLED WITH WATER.**

IMPORTANT

If this water heater is installed in a closed water supply system, such as the one having a back-flow preventer, check valve, pressure reducing valve, or water meter with check valve in the cold-water supply, provisions shall be made to manage thermal expansion. DO NOT operate this water heater in a closed water supply system without proper provisions. A properly sized and properly installed thermal expansion tank and/or other device(s) must be installed. Work with your installation professional, your water supplier, or local plumbing inspector on how to properly manage this situation. Warranties do NOT cover damages from thermal expansion, such as pressure bulges and/or deformities.

Water Connections continued-

⚠ WARNING

For protection against excessive temperatures and pressure, install temperature and pressure protective equipment required by local codes, but not less than a combination temperature and pressure relief valve certified by a nationally recognized testing laboratory that maintains periodic inspection of production of listed equipment or materials as meeting the requirements of the *Standard for Relief Valves and Automatic Gas Shutoff Devices for Hot Water Supply Systems, ANS Z21.22 or the Standard CAN1-4.4. Temperature and Pressure and the Standard CAN1-4.4, Temperature, Pressure, Temperature and Pressure Relief Valves and Vacuum Relief Valves*. The combination temperature and pressure relief valve must be marked with a maximum set pressure not to exceed the maximum working pressure of the water heater. The combination temperature and pressure relief valve must also have an hourly rated temperature steam BTU discharge capacity not less than the hourly rating of the water heater.

Install the combination temperature and pressure relief valve into the opening provided and marked for this purpose on the water heater.

Note: Some models may already be equipped or supplied with a combination temperature and pressure relief valve. Verify that the combination temperature and pressure relief valve is in compliance with local codes. If the combination temperature and pressure relief valve does not comply with local codes, replace it with one that does. Follow the installation instructions above on this page.

Install a discharge line so that water discharged from the combination temperature and pressure relief valve will exit within 6 in. (15.2 cm) above or any distance below the structural floor and cannot contact any live electrical part. The discharge line is to be installed to allow for complete drainage of both the combination temperature and pressure relief valve and the discharge line. The discharge opening must not be subjected to blockage or freezing. **DO NOT** thread, plug or cap the discharge line. It is recommended that a minimum clearance of 4 in. (10.2 cm) be provided on the side of the water heater for servicing and maintenance of the combination temperature and pressure relief valve.

DO NOT place a valve between the combination temperature and pressure relief valve and the tank.

⚠ WARNING

Hydrogen gas can be produced in an operating water heater that has not had water drawn from the tank for a long period of time (generally two weeks or more). Hydrogen gas is extremely flammable. To prevent the possibility of injury under these conditions, we recommend the hot water faucet to be open for several minutes at the kitchen sink before you use any electrical appliance which is connected to the hot water system. If hydrogen is present, there will be an unusual sound such as air escaping through the pipes as hot water begins to flow. **DO NOT** smoke or have open flame near the faucet at the time it is open.

This water heater can deliver scalding temperature water at any faucet in the system. Be careful whenever using hot water to avoid scalding injury. Certain appliances such as dishwashers and automatic clothes washers may require increased temperature water. By setting the thermostat on this water heater to obtain the increased temperature water required by these appliances, you may create the potential for scald injury. To protect against injury, an ASSE approved mixing valve should be installed in the water system. This valve will reduce point of discharge temperature by mixing cold and hot water in branch supply lines. Such valves are available from the manufacturer of this water heater or a local plumbing supplier. Please consult with a plumbing professional.

Water Connections continued-

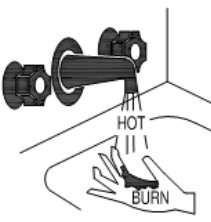

Water temperature over 125°F (52°C) can cause severe burns instantly or death from scalds.

Children, disabled, and elderly are at highest risk of being scalded.

Review this instruction manual before setting temperature at water heater.

Feel water before bathing or showering.

Temperature limiting valves are available, contact local plumbing supplier.

Approximate Time/Temperature Relationships in Scalds

120°F (49°C)	More than 5 minutes
125°F (52°C)	1 1/2 to 2 minutes
130°F (54°C)	About 30 seconds
135°F (57°C)	About 10 seconds
140°F (60°C)	Less than 5 seconds
145°F (63°C)	Less than 3 seconds
150°F (66°C)	About 1 1/2 seconds
155°F (68°C)	About 1 second

Condensate Drain Connection

This is a condensing water heater and requires a drain to allow the condensate to discharge safely. If a drain is not in close proximity, a condensate pump may be required to pump the condensate to the closest drain. A self-priming trap is integrated in the condensate/pressure tube, allowing the connection to the 1/2" (1.3 cm) port to run directly to the drain without an external trap connected. The preferred connection to the condensate port is with plastic pipe and fittings. Tubing is an acceptable alternative to plastic pipe. If tubing is applied, ensure it is properly secured. Ensure that no part is elevated above the drain port. Make sure that the condensate trap and components comply with local codes. Verify all condensate tubing is properly connected from the blower for proper drainage. **DO NOT** use copper tubing, iron, or steel pipe for the condensate drain line. Verify that the condensate drain line slopes down, away from the water heater at least 1/8"/ft. (.3 cm/.3 m) toward the drain. Upon initial startup, a gurgling sound may come from the condensate drain while the trap is being primed. This gurgle will cease once the trap is primed.

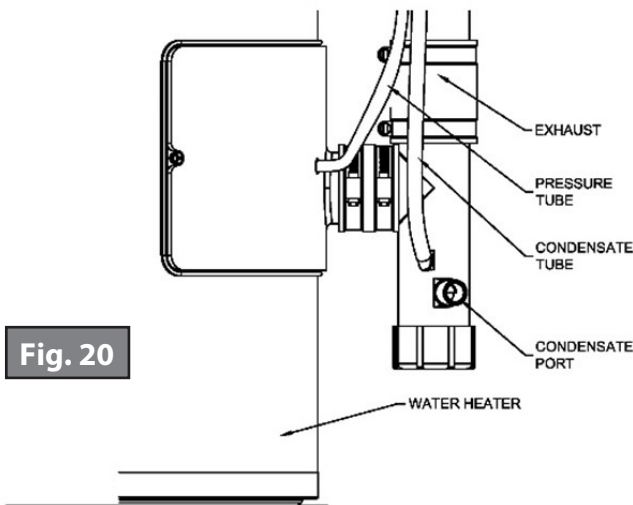

Condensate Drain Connection continued-

IMPORTANT

Condensate from this water heater is mildly acidic. Please note that some local codes require that condensate is treated by using a pH neutralizing filter prior to disposal.

⚠ CAUTION

The condensate drain pipe must **NOT** be routed through an area subject to below freezing temperatures. Ensure that the condensate can drain freely and free of debris to allow proper operation. **DO NOT** install any portion of the condensate trap above the condensate port on the water heater. Blockage of the condensate will make the water heater inoperable. Verify all tubing for condensate is properly connected from the blower for proper drainage.

IF A DRAIN IS NOT IN CLOSE PROXIMITY, A CONDENSATE PUMP MAY BE REQUIRED TO PUMP THE CONDENSATE TO THE CLOSEST DRAIN.

Gas Connections

⚠ WARNING

Prior to connecting the gas supply line to a gas fired water heater, ensure that the gas supply line **DOES NOT** have moisture/water or dirt/scale inside the gas line. Commonly this check is done at the lowest point in the gas distribution system prior to gas burning appliances.

The gas supply lines must meet all requirements of the National Fuel Gas Code (ANSI Z223.1-Latest Edition), or in Canada CAN/CGA B149.1 Natural Gas Installation Code (Latest Edition) or CAN/CGA B149.2 Propane Installation Code (Latest Edition).

The minimum permissible gas supply pressure for the purpose of input adjustment is 1 in. (0.25 kPa) water column above the operating manifold pressure. See the rating plate and gas valve for the manifold pressure and gas type. The maximum permissible gas supply pressure is 14 in. (3.5 kPa) water column for natural gas and liquefied petroleum gases/propane gas.

1. Connect this water heater only to the type of gas (Natural or Propane gas) as shown on the rating plate. Use clean black iron pipe or equivalent material approved by local codes and ordinances (dirt and scale from the pipe can enter the gas valve and cause it to malfunction). The inlet gas line must have a minimum length of 3 in. (7.6 cm) drip leg (sediment trap) installed as close to the water heater's gas valve as possible. A ground joint union must be installed as close to the water heater as possible in the gas supply line feeding the water heater to permit servicing of the water heater. Compounds used on the threaded joints of the gas piping must be resistant to the action of liquefied petroleum gases/propane gas. **DO NOT** apply pipe dope to the gas valve inlet and make certain that no pipe dope has become lodged in the inlet screen of the gas valve. Extreme care must be taken to ensure no pipe dope enters the gas valve. Avoid excessive torque when tightening the gas supply line to the gas valve. Excessive torque may result in cracking of the gas valve housing and could create a gas leak. The suggested maximum torque is 31.5 ft. lbs. (4.4 kg-m).

Gas Connections continued-

⚠ WARNING

The manufacturer of this water heater will not be liable for any damage or injury caused as a result of a cracked gas inlet as a result of excessive torque.

- This water heater and its gas connection must be leak tested before placing the water heater in operation. Check for gas leaks with a soap and water solution and a brush or a commercial leak detector fluid. **NEVER USE A MATCH OR OPEN FLAME FOR TESTING!**

⚠ CAUTION

The water heater and individual shutoff valve must be disconnected from the gas supply piping system during any pressure testing of the system at test pressures in excess of 1/2 psi (3.5 kPa). The water heater must be isolated from the gas supply piping system by closing its manual shutoff valve during any pressure testing of the gas supply system at test pressures equal to or less than 1/2 psi (3.5 kPa). The supply line must be capped when not connected to the water heater.

- While checking for leaks care must be taken to prevent solution from contacting the electrical connections at the control. If electrical connections at the control become wet, they must be thoroughly dried before attempting to operate the water heater.



Electrical Connections

All electrical wiring and connections must be in accordance with the National Electric Code ANSI/NFPA No. 70 (Latest Edition), or the Canadian Electrical Code C22.1 (Latest Edition) and any local codes which may apply. The water heater must be electrically grounded.

If a flexible line cord and plug is permitted by local code, then provide a 3-wire grounding type receptacle within 6 ft. (1.9 m) of the water heater and use the flexible cord provided. **DO NOT** plug the line cord into a receptacle that can have its power supply interrupted by a switch that is used to turn on and off lights.

If wiring in conduit is required, cut the flexible line cord flush with the bushing. Remove the junction box cover and cut the three wires from the line cord at the bushing inside of the junction box. Drill a hole to receive the 1/2 in. (1.3 cm) electrical conduit connector on the backside of the blower. Wire the power supply into the circuit at the appropriate locations. Replace the junction box cover.

⚠ CAUTION

Turn OFF or disconnect the electrical power supply to the water heater before servicing. Label all wires prior to disconnection when servicing controls. Wiring errors can cause improper and dangerous operation. Verify proper operation after servicing.

Wiring Diagram

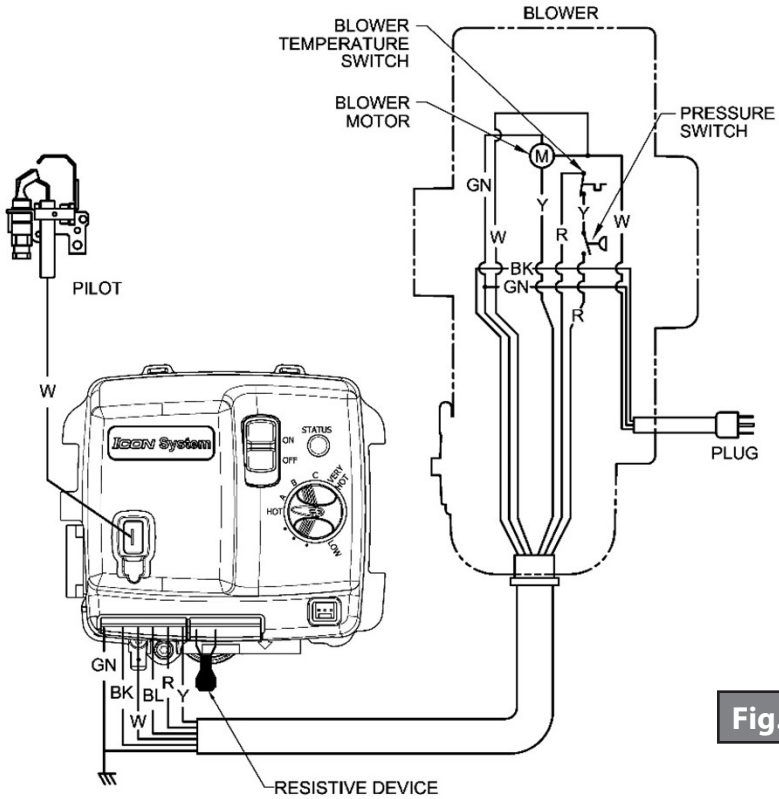
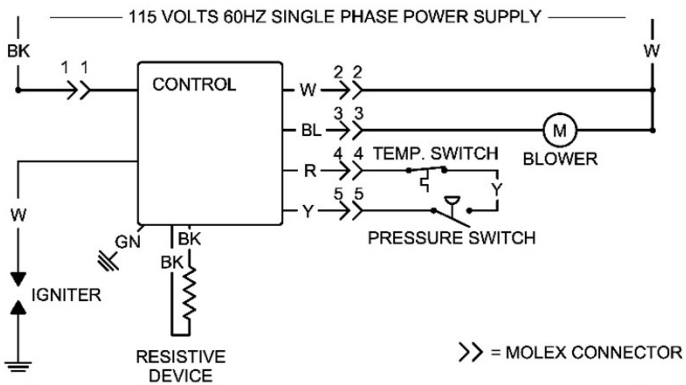

Fig. 21



ELECTRICAL RATING
115 VOLTS 60HZ LESS THAN 12 AMPS

IF ANY OF THE ORIGINAL WIRES SUPPLIED WITH THE APPLIANCE MUST BE REPLACED, IT MUST BE REPLACED WITH APPLIANCE WIRE MATERIAL WITH A MINIMUM TEMPERATURE RATING OF 105°C AND A MINIMUM SIZE OF NO. 18 AWG.

TANK MUST BE ELECTRICALLY GROUNDED
 LE RESERVOIR DOIT ETRE ELECTRIQUEMENT FONDU

GENERAL OPERATION

WARNING

Water heaters are heat producing appliances. To avoid damage or injury there must be no materials stored against the water heater or vent-air intake system, and proper care must be taken to avoid unnecessary contact (especially by children) with the water heater and vent-air intake system. **UNDER NO CIRCUMSTANCES SHOULD FLAMMABLE MATERIALS, SUCH AS GASOLINE OR PAINT THINNER BE USED OR STORED IN THE VICINITY OF THIS WATER HEATER, VENT-AIR INTAKE SYSTEM OR IN ANY LOCATION FROM WHICH FUMES COULD REACH THE WATER HEATER OR VENT-AIR INTAKE SYSTEM.**

TO FILL THE WATER HEATER:

1. Close the water heater drain valve by turning the stem clockwise. Note that the drain valve is fully closed with a $\frac{1}{4}$ turn.
2. Open the cold water supply shut-off valve.
3. Open several hot water faucets to allow air to escape from the system.
4. When a steady stream of water flows from the faucets, the water heater is filled. Close the faucets and check for water leaks at the water heater drain valve, combination temperature and pressure relief valve and the hot and cold water connections.

TO DRAIN THE WATER HEATER:

Should it become necessary to completely drain the water heater, make sure you follow the steps below:

1. Shut off the gas supply to the water heater.
2. Turn off/disconnect all electric power to the water heater.
3. Close the cold water supply shut-off valve.
4. Open the drain valve on the water heater by turning the stem counter-clockwise. Note that the drain valve is full open with a $\frac{1}{4}$ turn. The drain valve has threads on the end that will allow the connection of a standard hose coupling.
5. Open a hot water faucet to allow air to enter the system.

To refill the water heater, refer to "TO FILL THE WATER HEATER" from above.

Lighting and Shutdown Instructions

FOR YOUR SAFETY READ BEFORE LIGHTING

WARNING: If you do not follow these instructions exactly, a fire or explosion may result causing property damage, personal injury or loss of life.

- A. This appliance is equipped with an ignition device which automatically lights the pilot. Do not try to light the pilot by hand.
- B. BEFORE OPERATING smell all around the appliance area for gas. Be sure to smell next to the floor because some gas is heavier than air and will settle to the floor.
- WHAT TO DO IF YOU SMELL GAS**
- Do not try to light any appliance.
 - Do not touch any electrical switch; do not use any phone in your building.
 - Immediately call your gas supplier from a neighbor's phone. Follow the gas supplier's instructions.
- If you cannot reach your gas supplier, call the fire department.
- C. Use only your hand to slide the gas control switch. Never use tools. If the switch cannot be moved by hand, do not try to repair it, call a service technician. Force or attempted repair may result in a fire or explosion.
- D. Do not use this appliance if any part has been under water. Immediately call a qualified service technician to inspect the appliance and to replace any part of the control system and any gas control which has been under water.

OPERATING INSTRUCTIONS

1. STOP! Read the safety information above.
2. Turn off all electric power to the appliance.
3. Set the thermostat to lowest setting.
4. This appliance is equipped with an ignition device which automatically lights the pilot. Do not try to light the pilot by hand.
5. Slide the switch on the right side of the gas valve down to the "OFF" position
6. Wait five (5) minutes to clear out any gas, then smell for gas, including near the floor. If you the smell gas, STOP! Follow "B" in the safety information at left on this label. If you don't smell gas, go to the next step.
7. Slide the switch on the right side of the gas valve up to the "ON" position.
8. Set thermostat to desired setting.
9. Turn on all electric power to the appliance.
10. If the appliance will not operate, follow the instructions "To Turn Off Gas To Appliance" and call your service technician or gas supplier.

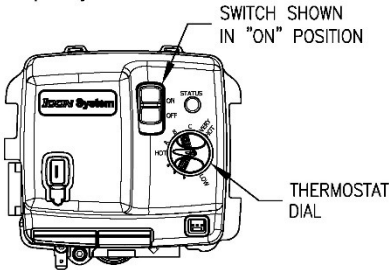

TO TURN OFF GAS TO APPLIANCE

1. Turn off all electric power to the appliance if service is to be performed.
2. Set the thermostat to the lowest setting.
3. Slide the switch on the right side of the gas valve down to the "OFF" position.

Fig. 22

Thermostat Adjustment

The thermostat dial is adjusted to its lowest setting when shipped from the factory. When adjusting the thermostat, it should be remembered that lower temperature settings are more energy efficient. To adjust the thermostat, turn the dial clockwise until the minimum acceptable temperature is set. It is suggested that the starting point setting not exceed the 120°F (49°C) or “HOT” setting on the thermostat.

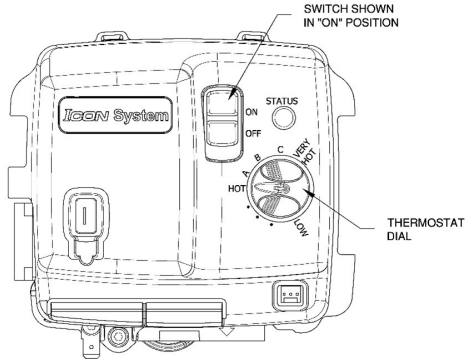

Fig. 23

⚠ DANGER

Hotter water increases the risk of scald injury. Scalding may occur within 5 seconds at a temperature setting of 140°F (60°C). To protect against hot water injury, install an ASSE approved mixing valve in the water system. This valve will reduce point of discharge water temperatures by mixing cold and hot water in branch water lines. A licensed plumbing professional or local plumbing authority should be consulted.

Note: This water heater is equipped with an energy cut out device to prevent overheating. Should overheating occur, turn off the electrical supply to the water heater and contact a qualified service technician.

Burner Flame Check

Steel Burner: These models are equipped with self-adjusting air mixture and do not have an adjustable air shutter (see Figure 24). At periodic intervals a visual check of the main burner and pilot flames should be made to determine if they are burning properly. The main burner flame should light smoothly from the pilot.

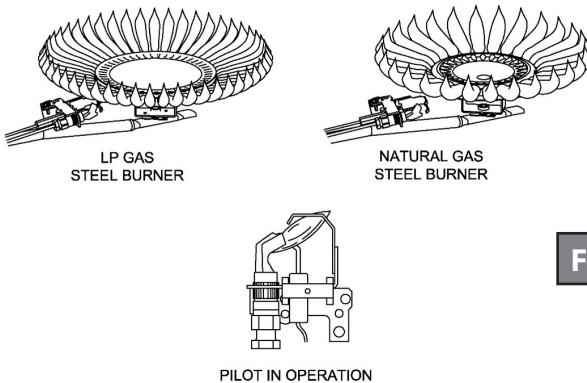

Fig. 24

⚠ WARNING

DO NOT run out of propane gas. Damage to the water heater may occur.

MAINTENANCE

⚠ WARNING

Water heaters are heat producing appliances. To avoid damage or injury there must be no materials stored against the water heater or vent-air intake system, and proper care must be taken to avoid unnecessary contact (especially by children) with the water heater and vent-air intake system. **UNDER NO CIRCUMSTANCES SHOULD FLAMMABLE MATERIALS, SUCH AS GASOLINE OR PAINT THINNER BE USED OR STORED IN THE VICINITY OF THIS WATER HEATER, VENT-AIR INTAKE SYSTEM OR IN ANY LOCATION FROM WHICH FUMES COULD REACH THE WATER HEATER OR VENT-AIR INTAKE SYSTEM.**

IMPORTANT

The water heater should be inspected at a minimum annually by a qualified service technician for damaged components and/or joints not sealed. **DO NOT** operate this water heater if any part is found damaged or if any joint is found not sealed.

The following maintenance should be performed by a qualified service technician at the minimum periodic intervals suggested below. In some installations, the maintenance interval may be more frequent depending on the amount of use and the operating conditions of the water heater. Regular inspection and maintenance of the water heater and vent-air intake system will help to insure safe and reliable operation.

1. Annually check the operation of the thermostat.
2. The flow of combustion and ventilation air **MUST NOT** be restricted. Clear the combustion air openings of any dirt, dust, or other restrictions.

⚠ WARNING

THE VENTILATION AIR SYSTEM MAY BE HOT.

3. At all times keep the water heater area clear and free from combustible materials, gasoline and other flammable vapors and liquids.
4. Bi-annually conduct a visual check of the main and pilot burner flames to determine that they are burning properly. See the Burner Flame Check section for illustration. If sooting or other burner anomalies are evident, shut down the water heater by turning off the gas per the instructions listed in this manual or as listed on the water heater.
5. Annually remove the inner door and main burner assembly to clean orifices and related parts of any dirt or other foreign material. Inspect the burner ports for obstructions or debris and clean with a wire brush as needed. Wire brush and/or vacuum clean the combustion chamber as needed to remove scale deposits and debris. **NOTE:** It is imperative for proper operation of the water heater that the inner door be replaced in the original location.

⚠ WARNING

When lifting lever of the combination temperature and pressure relief valve, hot water will be released under pressure. Be careful that any released water does not result in bodily injury or property damage.

6. At least once a year, check the combination temperature and pressure relief valve to ensure that the valve has not become encrusted with lime. Lift the lever at the top of the valve several times until the valve seats properly without leaking and operates freely.

Maintenance continued-

WARNING

DO NOT ALLOW THE WATER HEATER TO RUN OUT OF PROPANE.

7. Monthly drain off a gallon of water to remove silt and sediment.

WARNING

THIS WATER MAY BE HOT.

8. If the combination temperature and pressure relief valve on the appliance discharges periodically, this may be due to thermal expansion in a closed water supply system. Contact the water supplier or local plumbing inspector on how to correct this situation. **DO NOT** plug the combination temperature and pressure relief valve outlet.
9. Combination sacrificial anode rods have been installed to extend tank life. These anode rods should be inspected periodically (every 2 years) and replaced when necessary to prolong tank life. Water conditions in your area will influence the time interval for inspection and replacement of an anode rod. Contact the plumbing professional who installed the water heater, or the manufacturer listed on the rating plate for anode replacement information. The use of a water softener may increase the speed of anode consumption. More frequent inspection of the anodes is needed when using softened (or phosphate treated) water.
10. The blower has sealed motor bearings and does **NOT** require adding oil.
11. Vent pipe and vent hood screen should be cleaned of any foreign material. The screen is located inside the vent hood outlet and is accessible from the outside of the hood. **Do not** reach inside the vent hood when the water heater is in operation.

CAUTION

FOR YOUR SAFETY, DO NOT ATTEMPT REPAIR OF GAS CONTROL, BURNERS OR GAS PIPING. REFER REPAIRS TO A QUALIFIED SERVICE TECHNICIAN.

Contact your supplier or plumbing professional for replacement parts or contact the company at the address given on the rating plate of the water heater. For faster service, provide the part name, model and serial numbers of the water heater when ordering parts.

IMPORTANT

READ THE WARRANTY FOR A FULL EXPLANATION OF THE LENGTH OF TIME THAT PARTS AND THE WATER HEATER ARE WARRANTED.

This product is covered under one or more of the following patents and or patent pending applications:

CA2,430,807 CA2,844,271 EP1369647 GB1369647 NL1369647 TWI276761 US7,559,293
US7,900,589 US7,007,748 CA2,476,685 US7,063,132 CA2,409,271 US6,684,821 US7,337,517
US7,665,211 US7,665,210 US7,699,026 CA2,504,824 US6,935,280 AU2007201423
CA2,583,609 EP1840484 GB1840484 NL0840484 US7,634,976 US7,270,087 US7/621,238
US7,334,419 US7,866,168 CA2,491,181 US7,063,133 CA2,677,549 US8,082,888
AU2007201424 CA2,583,108 EP1840481 GB1840481 NL1840481 CA2,659,534 US7,971,560
US7,992,526 US8,146,772 US8,707,558 CA2,548,958 MX243220 US6,422,178 TWI649522
US9,429,337 CA3,001,716 GB2558134 GB2013252.8 US10,866,010 US17/109,618
US10,503,183 US20/42096 CA2,949,830 DE112015002523.5 GB2540513 US9,574,792
US15/436,425 CA3,059,965 EP18784108.5 MX/a/2019/012268 US15/486,816 US17/038,087
US7,007,316 US7,243,381 CA2,784,312 US8,787,742 DE112014002713.8 GB2533862
US9,964,241 US6,644,393 US8,851,022 USD636,857 US8,931,438 CA2,899,271 US10,495,343
CA2,918,211 US10,094,619 US15/621,063 US16/474,833 US16/281,599

Complete the following information and retain for future reference:

Model No: _____

Serial No: _____

Service Phone: _____

Days: _____ **Nights:** _____

Address: _____

Supplier: _____

Supplier Phone No: _____

Troubleshooting

LED Status	Control Status	Probable Cause
None (LED not on or flashing)	Electrical power not present.	Control power switch in "OFF" position. Supply voltage interrupted.
One short flash every four seconds	Stand-by mode, Thermostat is satisfied (no faults).	Temperature demand is satisfied (no call for heat).
Alternates bright and dim (Heartbeat)	Thermostat calling for heat (no fault).	Tank temperature below set point of thermostat.
Short flash once every second	Weak pilot signal on last call for heat.	<ol style="list-style-type: none"> 1. Unstable pilot. 2. Pilot tube block or restricted. 3. Oxidation build up on pilot electrode. 4. Wire damage to pilot assembly or bad connection at gas valve. 5. Low gas pressure.
Short flash once every two seconds	Idle remote command off.	<ol style="list-style-type: none"> 1. Control put in idle or Sabbath mode from accessory module.
Two flashes, three second pause	Pressure switch not working-closed position.	<ol style="list-style-type: none"> 1. Pressure switch tubing kinked or blocked. 2. Blocked pressure tap on switch. 3. Faulty pressure switch.
Three flashes, three second pause	Pressure switch or blower temperature switch not working-open position	<ol style="list-style-type: none"> 1. Vent blockage or improper vent configuration. 2. Pressure switch tubing kinked or blocked. 3. Blower not spinning up to speed. 4. Vent temperature too high. 5. Blocked condensate drain. 6. Faulty pressure switch or vent limit switch.
Four flashes, three second pause	Excessive tank temperature. System must be reset.	<ol style="list-style-type: none"> 1. Excessive sediment. 2. Hot water entering the tank from another source in the potable loop. 3. Faulty gas valve.
Five flashes, three second pause	False pilot flame present.	Pilot valve stuck in open position.
Six flashes-one flash, three second pause (Soft lockout)	Failed to light pilot. System auto resets after 5 minutes.	<ol style="list-style-type: none"> 1. Unstable pilot. 2. Pilot tube blocked or restricted. 3. Oxidation build up on pilot electrode. 4. Wire damage to pilot assembly or bad connection at gas valve. 5. Low gas pressure.

Troubleshooting continued-

LED Status	Control Status	Probable Cause
Six flashes-two flashes, three second pause (Soft lockout)	Pressure switch or blower temperature switch opened during burner operation. System auto resets after 5 minutes	<ol style="list-style-type: none"> 1. Pressure switch tubing kinked or blocked. 2. Vent blockage or improper vent configuration. 3. Vent termination being affected by windy conditions. 4. Blower not spinning up to speed. 5. Vent temperature too high. 6. Faulty pressure switch or blower temperature switch.
Six flashes-three flashes, three second pause (Soft lockout)	Pilot flame extinguished. System resets after 5 minutes.	<ol style="list-style-type: none"> 1. Unstable pilot. 2. Pilot tube blocked or restricted. 3. Oxidation build up on pilot electrode. 4. Wire damage to pilot assembly or bad connection at gas valve. 5. Insufficient combustion air. 6. Low gas pressure.
Six flashes-four flashes, three second pause (Soft lockout)	Undesired-false pilot flame sensed. System auto resets.	Pilot valve stuck in open position.
Seven flashes, three second pause	Flammable vapor sensor fault detected, see warning label.	<ol style="list-style-type: none"> 1. Flammable vapor present. 2. Flammable vapor sensor exposed to excessive moisture. 3. Flammable vapor sensor exposed to extreme 4. ambient temperature. 5. Simulated resistive device removed or out of range (if applicable).
Eight flashes-one flash, three second pause	Flammable vapor sensor out of specification.	<ol style="list-style-type: none"> 1. Flammable vapor sensor out of specification. 2. Possible short.
Eight flashes, two flashes, three second pause	Temperature sensor fault.	<ol style="list-style-type: none"> 1. Damage to sensor or wire in control's well. 2. Control's sensor resistance out of range. 3. Replace control.
Eight flashes-three flashes, three second pause	Electronics fault detected.	<ol style="list-style-type: none"> 1. Verify control is not wet or physically damaged. 2. Reset control on/off switch. 3. Replace electronic module if 8-3 error persists.
Eight flashes-four flashes, three second pause	Gas valve fault detected.	<ol style="list-style-type: none"> 1. Verify control is not wet or physically damaged. 2. Reset control on/off switch. 3. Replace gas control if 8-4 error persists

Control Sequence of Operation

Start-up Sequence

Upon powering up, the control checks for the presence of the resistive plug. If the resistance is in the expected range, the control will begin normal operation after 5 to 8 seconds.

Normal Heating Sequence

1. The thermostat senses a need for heat.
2. The control checks the pressure switch condition.
3. If the pressure switch is open, the control sends power to the blower motor.
4. The blower starts moving combustion air through the combustion system.
5. The pressure switch closes.
6. The control senses the closed pressure switch and starts the ignition process by providing a spark at the pilot electrode and allowing gas to flow to the pilot.
7. When the pilot is lit, the gas control senses the pilot flame and opens the main gas valve.
8. The main burner is lit.
9. The main burner and blower continue to operate until the thermostat is satisfied.
10. When the thermostat is satisfied the main and pilot gas valves close.
11. The blower operates for a short post purge period before shutting down.
12. The water heater remains in the stand-by mode until the next call for heat.

PARTS DIAGRAM

(Actual Water Heater Visual Representation May Vary)

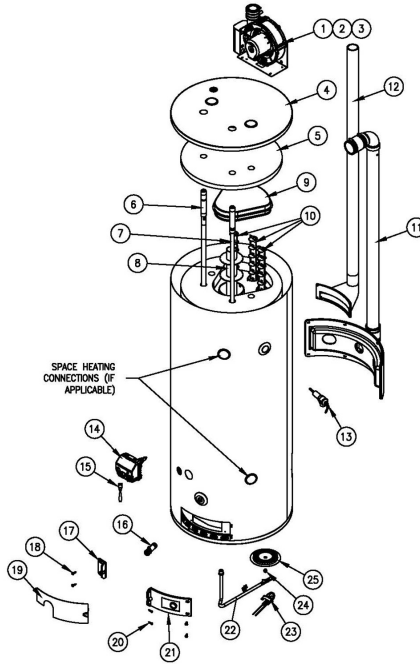

PART NAME AND DESCRIPTION

1. Blower Assembly	14. Gas Valve
2. Pressure Switches (not shown)	15. Resistive Device
3. Blower Temp. Switch (not shown)	16. Drain Valve
4. Jacket Head	17. Inner Door (Left)
5. Top Insulation	18. Screw (Inner Door)
6. Anode-Nipple	19. Outer Door
7. Diptube-Nipple	20. Screw (Outer Door)
8. Flue Core	21. Inner Door (Right)
9. Flue Collector	22. Gas Feedline
10. Flue Baffles	23. Gas Pilot
11. Exhaust Collector/Venting	24. Gas Orifice
12. Intake Boot/Pipe	25. Burner
13. T & P Valve	

THE FOLLOWING INSTRUCTIONS ARE FOR INSTALLATION OF GAS WATER HEATERS SUITABLE FOR WATER (POTABLE) HEATING AND SPACE HEATING:

1. All piping components connected to this water heater for space heating applications must be suitable for use with potable water. In Massachusetts, space heating piping length **must not** exceed 50 feet.
2. Toxic chemicals, such as those used for boiler treatment, **must not** be introduced into potable water used for space heating.
3. This water heater **must not** be connected to an existing heating system or component(s) previously used with a non-potable water heating appliance.
4. When the system requires water for space heating at temperatures higher than required for other means, an approved mixing valve must be installed to temper the water for those uses in order to reduce the scald hazard potential

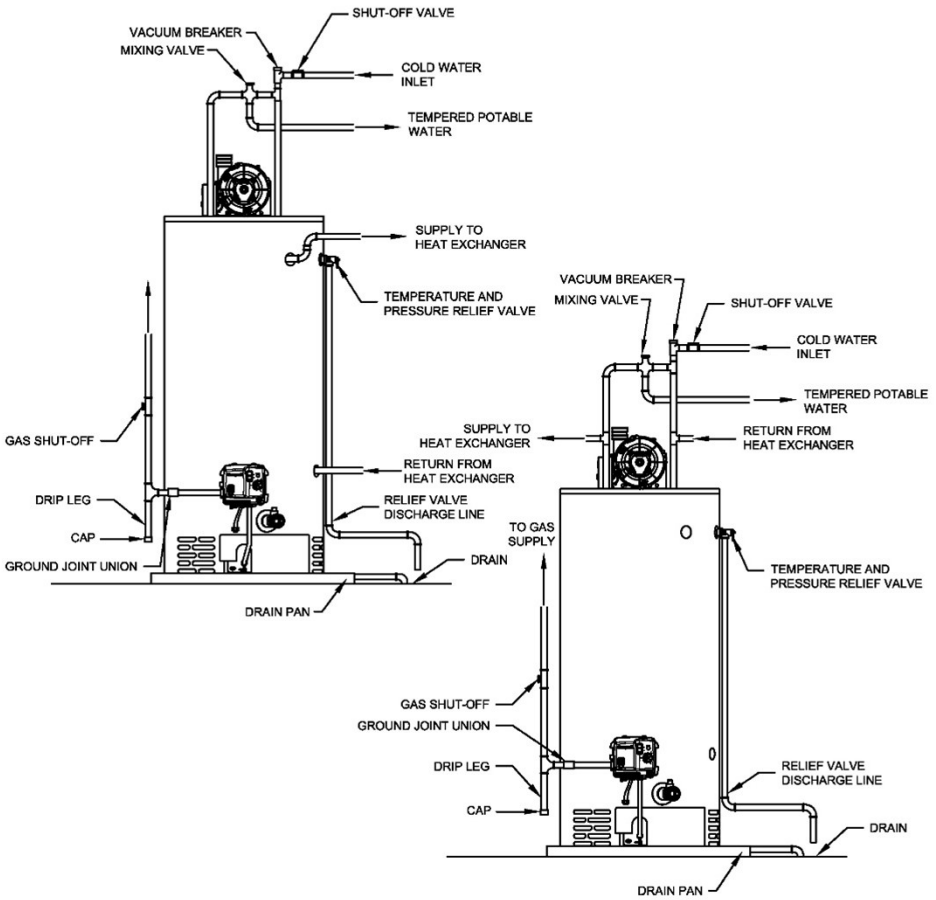

Notes

A large grid of small dots arranged in approximately 25 columns and 40 rows, intended for taking notes.