

INTEGRATED MIXING DEVICE (IMD) INSTALLATION AND OPERATING INSTRUCTION MANUAL

For your family's comfort, safety and convenience, it is recommended this IMD be installed and serviced by a plumbing professional.

This manual will explain in detail the installation and maintenance of the integrated mixing device. We require that you carefully read this manual and refer to it if questions arise.

PRE-INSTALLATION

The following steps should be taken to ensure proper conditions for operation:

- Note all site parameters (pressure, temperature, etc.) and check against the integrated mixing device (IMD) specifications listed in Table 1. All specifications must be met prior to installing the IMD.
- This IMD **MUST NOT** be subjected to heat during installation as this may damage the internal parts.

CAUTION

If sweat fittings are to be used, DO NOT apply heat to the fittings on top of the water heater. Sweat the tubing to the adapter before fitting the adapter to the water connections. It is necessary that heat is not applied to the fittings to ensure appropriate operation.

- The valve **MUST NOT** be allowed to freeze. If the IMD is installed in a potentially freezing situation, suitable insulation must be fitted to prevent damage.
- **DO NOT** use excess thread sealant (in liquid, tape or other form) as this may cause the IMD to fail. The installer must ensure that thread sealant does not get into the internal parts.
- In order to install this IMD on a unit with a blower mounted on top, it is necessary to remove the blower prior to installation and replace the blower after installation of this IMD, or purchase an optional nipple extender kit, p/n 239-48429-00. See Step 2a(Figure 5a) and Step 3a(Figure 6a).
- If the water heater is gas-fired, the IMD must be installed before the draft hood.
- This manual is meant to be used in conjunction with the installation and operation manual (owners manual) for the water heater.
- Toxic chemicals, such as used for boiler treatment, shall not be introduced into IMD used for space heating. This IMD may never be connected to any existing heating system or component(s) previously used with a non-potable water heating system.

Leave a copy of this instruction manual with the water heater for future reference.

Recommend to the user that the IMD be checked annually to ensure its continued function.

INTEGRATED MIXING DEVICE - IMD SPECIFICATIONS

Table 1

Mixed water supply temperature range	100 - 145°F (38 - 63°C)
Water heater outlet temperature range	100 - 180°F (38 - 82°C)
Cold water inlet temperature range	33 - 80°F (1 - 27°C)
Device temperature stability (nominal)	note 1) ± 5°F (± 3.0°C) at 5 - 40 gpm (see
Temperature differential (between hot supply and outlet temperature)	27°F (15°C) (see note 2)
Hydrostatic pressure	150 psi (1034 kPa) maximum
Permitted supply pressure variation	± 10% (see note 3)
Flow rate (min)	0.25 gpm (0.9 L/m)
Flow rate (max)	19.2 gpm (72.0 L/m)
Cv	2.8 (mixed temp. of 95°F)(35°C) 1.8 (mixed temp. of 120°F)(49°C) 1.3 (mixed temp. of 140°F)(60°C)

Notes:

1. As tested in accordance with ASSE 1017.
2. This is the minimum difference required between the mixed water supply temperature and the water heater outlet temperature to enable the IMD to function correctly and ensure shut-off of outlet flow in the event of cold supply failure.
3. Maximum permitted variation in either supply pressure in order to control the mixed water supply temperature to within ± 3°F. Excessive changes in supply pressures may cause changes in mixed water supply temperature.

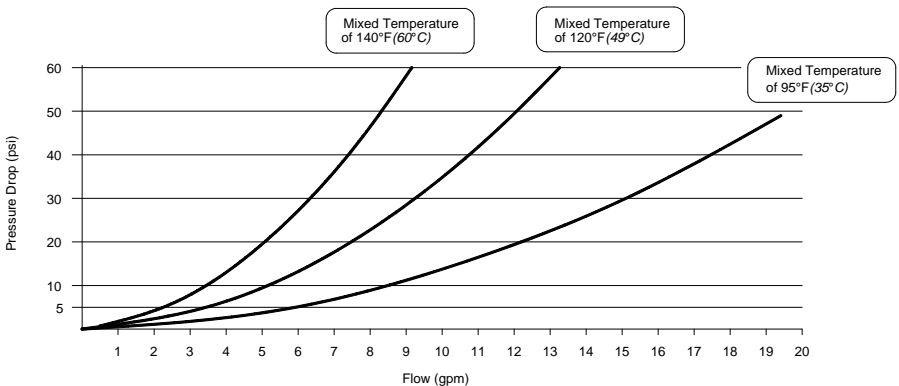

Remove all components from the package and check that all required components are included. The required components are: mixing device, cold water tee, flexible metal connector and thermostrip (see Figure 1).

Flexible metal connector

Mixing device

Instructions

Cold water tee

This kit may have two flexible connectors provided for water heaters with top water course connections at 8 inch and 11 inch spacing. Use the appropriate flexible metal connector.

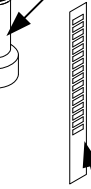
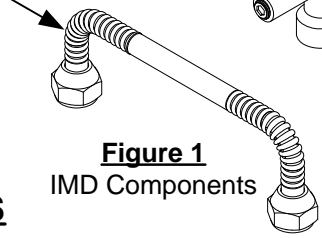

Thermostrip

Figure 1
IMD Components

WATER CONNECTIONS

The mixing device, cold water tee, flexible metal connector and thermostrip are integral parts of the water heater. This system improves hot water deliverability and must be installed. The integrated appliance is designed for a maximum working pressure of 150 p.s.i. (1034 kPa). Refer to the "Water Connections" section of the installation and operation instruction manual supplied with the water heater for additional instructions.

The mixing device is equipped with a 1/2" NPT alternate hot water outlet that draws unmixed very hot water from the tank. This outlet should be used if unmixed very hot water is needed at specific fixtures (laundry, dishwasher, etc...). It is also equipped with a 1/2" NPT optional recirculation inlet that must be utilized in conjunction with a check valve if a recirculation loop is used (see Figure 2).

⚠ WARNING

If recirculation loop water is returned to the water heater at any location other than the optional recirculation inlet, unmixed very hot water is exposed to the recirculation loop. Do not return recirculation loop to any other location other than "R" inlet of the mixing device.

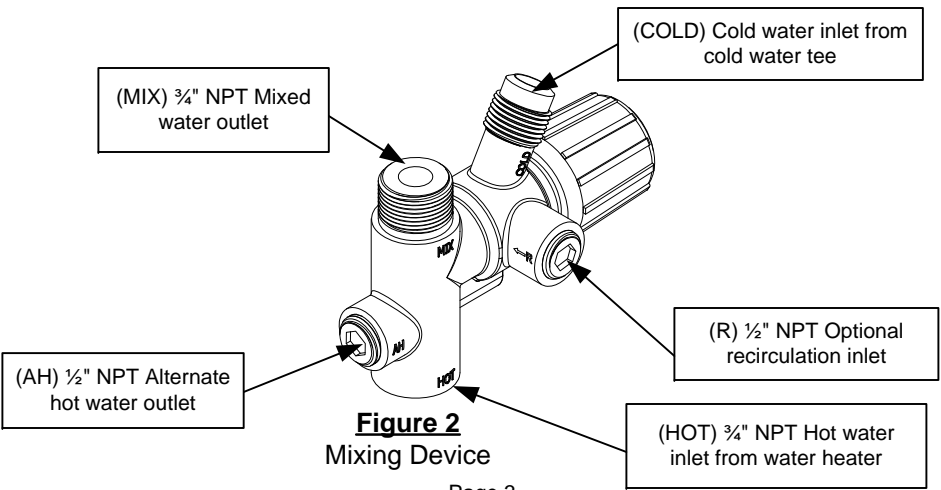

Figure 2
Mixing Device

WATER CONNECTIONS CONTINUED...

The cold water tee is equipped with a 1/4" NPT optional cold water outlet that draws cold water prior to the water heater (see Figure 3). This outlet may be used to connect cold water to refrigerator ice makers or other low flow applications.

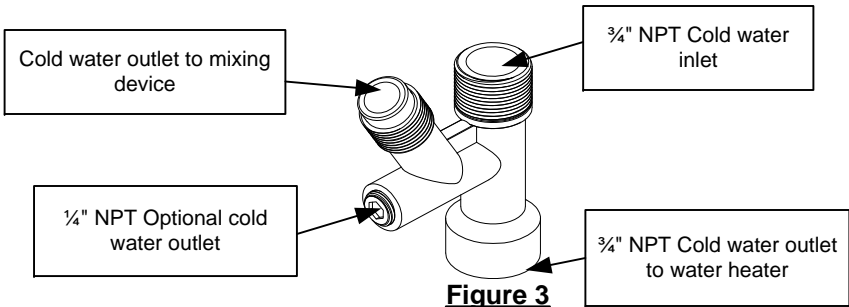

Figure 3
Cold water Tee

ASSEMBLY PROCEDURE

1. Twist and pull thread protectors with pliers or large regular screw driver to remove them from flexible metal connector as shown in Figure 4.

⚠ CAUTION

Do not damage flared connectors or threads on connector nuts when removing thread protectors.

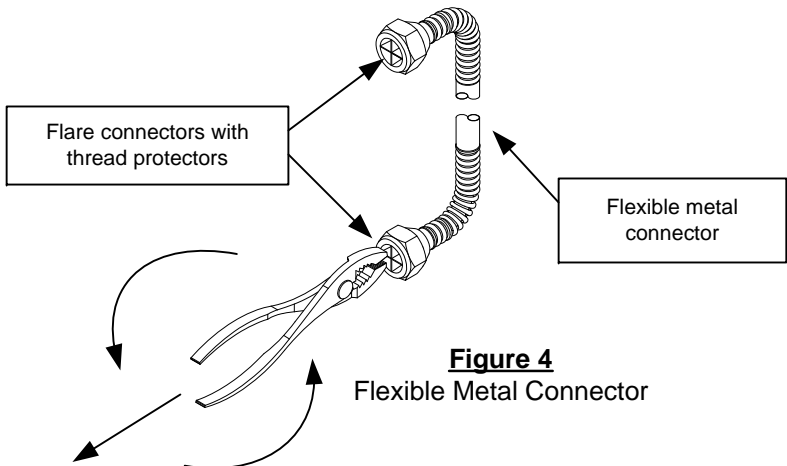

ASSEMBLY PROCEDURE CONTINUED...

2. Install the cold water tee onto the cold water inlet of the water heater. If installing on a water heater with 1" inlet fitting, use 1" NPT to 3/4" NPT brass reducer bushing and brass nipples. Tighten until leak tight and facing the front of the water heater as shown in Figure 5.

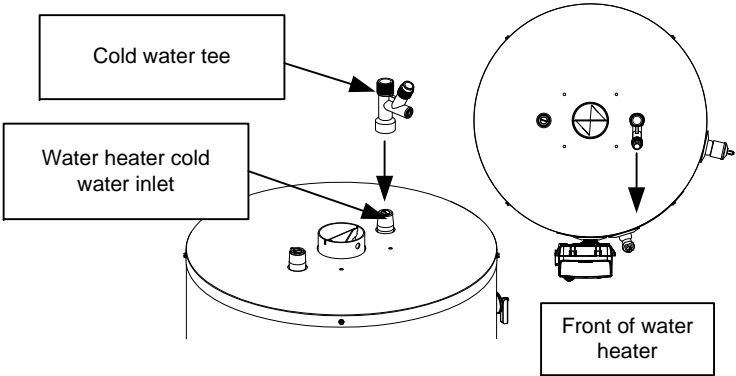

Figure 5
Installing Cold Water Tee

2a. OPTIONAL INSTALLATION: Install the cold water tee onto the extension that is installed onto the cold water inlet of the water heater. If installing on a water heater with 1" inlet fitting, use 1" NPT to 3/4" NPT brass reducer bushing and brass nipples. Tighten until leak tight and facing the front of the water heater as shown in Figure 5a.

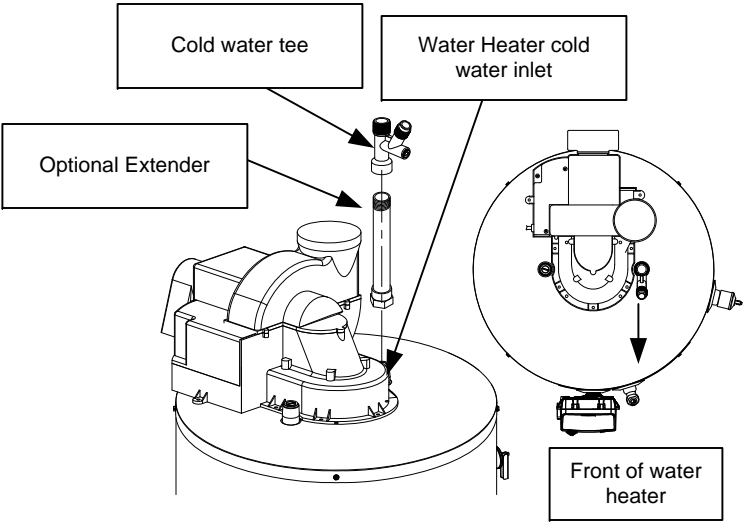

Figure 5a
Installing Cold Water Tee
with Optional Extender

ASSEMBLY PROCEDURE CONTINUED...

3. Install the mixing device onto the hot water outlet of the water heater. If installing on a water heater with 1" outlet fitting, use 1" NPT to 3/4" NPT brass reducer bushing and brass nipples. Tighten until leak tight and facing the front of the water heater as shown in Figure 6.

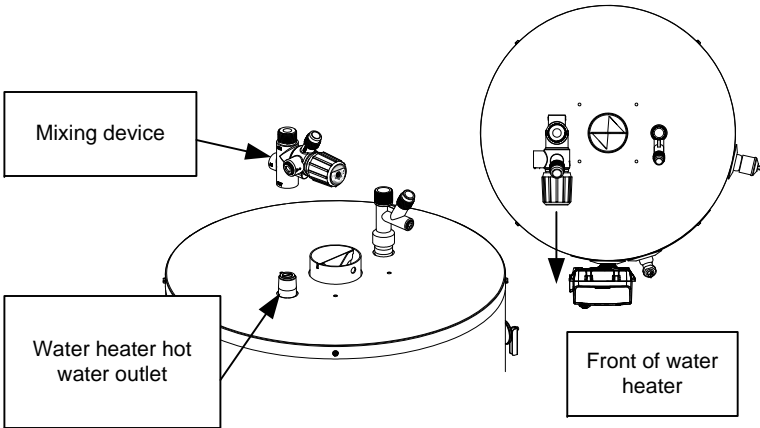

Figure 6
Installing Mixing Device

3a. OPTIONAL INSTALLATION: Install the mixing device onto the extension that is installed onto the hot water outlet of the water heater. If installing on a water heater with 1" outlet fitting, use 1" NPT to 3/4" NPT brass reducer bushing and brass nipples. Tighten until leak tight and facing the front of the water heater as shown in Figure 6a.

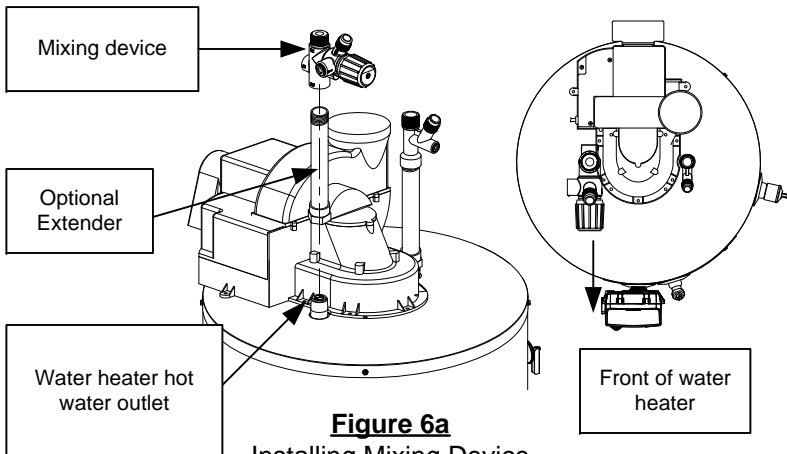

Figure 6a
Installing Mixing Device
with Optional Extender

ASSEMBLY PROCEDURE CONTINUED...

4. Install the flexible metal connector to the mixing device and cold water tee as shown in Figure 7. Tighten flare connectors until leak tight.

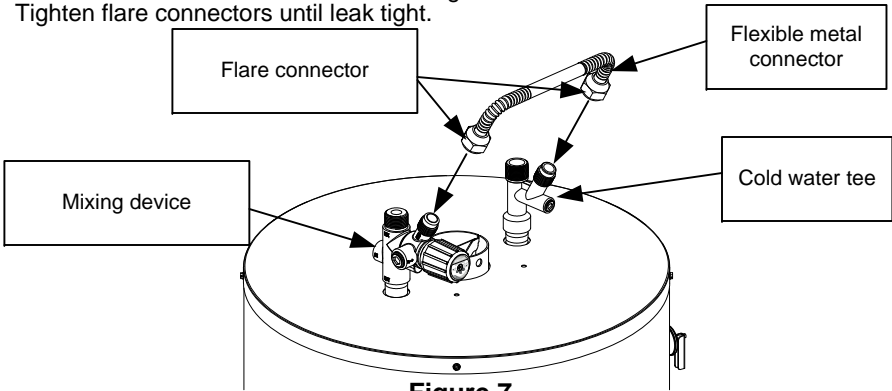

Figure 7

Installing Flexible Metal Connector

At this time the IMD should be leak tight. Continue installation of potable water system as indicated in the installation and operation instruction manual supplied with the water heater.

Once potable water system has been completely installed, install the thermostrip on the mixed water outlet pipe no more than 10 inches from mixing device as shown in Figure 8.

⚠ WARNING

If recirculation loop water is returned to the water heater at any location other than the optional recirculation inlet, unmixed very hot water is exposed to the recirculation loop. Do not return recirculation loop to any other location other than "R" inlet of the mixing device.

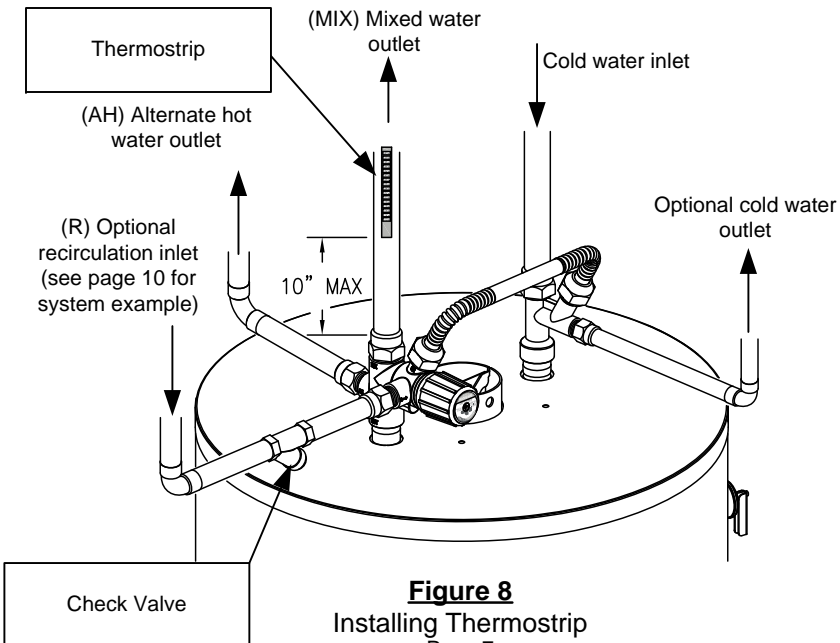

Figure 8

Installing Thermostrip

IMD CARE AND MAINTENANCE

WARNING

Hotter water increases the risk of scald injury. Scalding may occur within 5 seconds at a setting of 140°F (60°C). Water temperature over 125°F (52°C) can cause burns or death from scalds. Children, disabled and the elderly are at highest risks of being scalded. Please feel the water before bathing or showering.

WARNING

SCALDING

This water heater can deliver scalding temperature water at any faucet in the system. Be careful whenever using hot water to avoid scalding injury. By setting the thermostat on this water heater to obtain an increased water temperature, you may create the potential for scald injury. To protect against injury, you should install an ASSE approved thermostatic mixing valve (a device to limit the temperature of water to protect against scald injury via mixing hot and cold water supply) in the water system. This valve will reduce point of discharge temperature in branch supply lines. This water heater was shipped with an ASSE approved thermostatic mixing valve. Install this valve according to the directions in the mixing device container. **DO NOT OPERATE THIS WATER HEATER WITHOUT AN ASSE APPROVED THERMOSTATIC MIXING DEVICE.** If this water heater was shipped without an ASSE approved thermostatic mixing valve, contact the manufacturer.



DANGER

Water temperature over 125°F can cause severe burns instantly or death from scalds.

Children, disabled and elderly are at highest risk of being scalded.

Review this instruction manual before setting temperature at water heater.

Feel water before bathing or showering.

Temperature limiting valves are available.



APPROXIMATE TIME/TEMPERATURE RELATIONSHIP IN SCALDS	
120°F (49°C)	More than 5 minutes
125°F (52°C)	1 ½ to 2 minutes
130°F (54°C)	About 30 seconds
135°F (57°C)	About 10 seconds
140°F (60°C)	Less than 5 seconds
145°F (63°C)	Less than 3 seconds
150°F (66°C)	About 1 ½ seconds
155°F (68°C)	About 1 second

TEMPERATURE ADJUSTMENT

- Prior to adjusting the IMD, the water heater must be operational and deliver hot water within the Water Heater Outlet Temperature Range (100°F - 180°F) (38 - 82°C). Note that the water heater thermostat is factory set at approximately 120°F (49°C) or lower. For proper operation, the temperature setting on the water heater may be increased. Prior to measuring the Mixed Water Supply Temperature, allow the water heater to recover from the thermostat adjustment.
- Measure the Mixed Water Supply Temperature at the nearest faucet supplied by the integrated mixing device. A flow rate of 1 to 1.5 gpm (4 to 6 L/min) is recommended.
- An accurate temperature measuring device such as a thermometer must be used to ensure that a suitable temperature of mixed water is achieved.
- Allow the water to run until a steady temperature is reached. The amount of time necessary is dependant on the outlet's location to the water heater.

TEMPERATURE ADJUSTMENT CONTINUED...

1. The Mixed Water Supply Temperature may require adjustment. The IMD is set at approximately 120°F when the arrow on the hand wheel and the arrow on the casting are aligned.

a. To Increase Mixed Water Supply Temperature: Depress and rotate the hand wheel counter clockwise until the desired set point is reached (see Figure 9). Refer to thermostrip temperature reading for desired set point (hot water must be flowing at a minimum of 1 gpm to accurately read thermostrip). Ensure the hand wheel snaps back to the locked position once desired set point is reached.

b. To Decrease Mixed Water Supply Temperature: Depress and rotate the hand wheel clockwise until the desired set point is reached (see Figure 9). Refer to thermostrip temperature reading for desired set point (hot water must be flowing at a minimum of 1 gpm to accurately read thermostrip). Ensure the hand wheel snaps back to the locked position once desired set point is reached.

2. Verify that the desired set point is reached by allowing an appropriate amount of water to run from the nearest faucet supplied by the IMD.

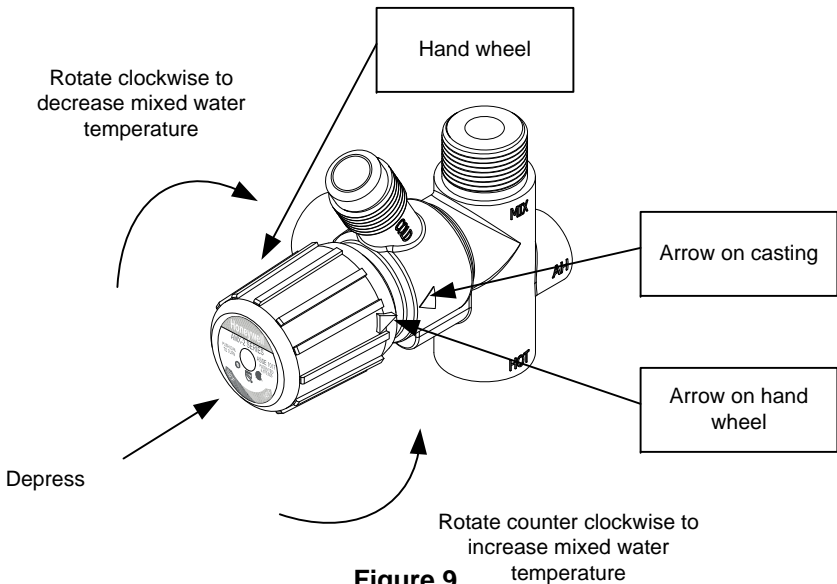

Figure 9
Adjusting Mixed Supply Temperature

CHECKING / SERVICING THIS DEVICE

- It is recommended that the IMD is checked annually to ensure proper system capabilities. Where adverse water conditions are applied, more frequent intervals are recommended.
- In checking the mixed water supply temperature, use the same faucet used in the initial installation temperature adjustment.
- There may be some variation in the water temperature from the IMD due to seasonal temperature variations in the cold water supply.
- **If the water supply is of poor quality, the internal components may jam requiring an additional filter or strainer to be fitted to the system. Contact a plumbing professional for appropriate materials and installation.**

RESIDENTIAL MODEL WITH HONEYWELL MIXING DEVICE AND RETURN CIRCULATION

(Maximum trickle flow for the recirculating water is ¼ to ½ gpm.)

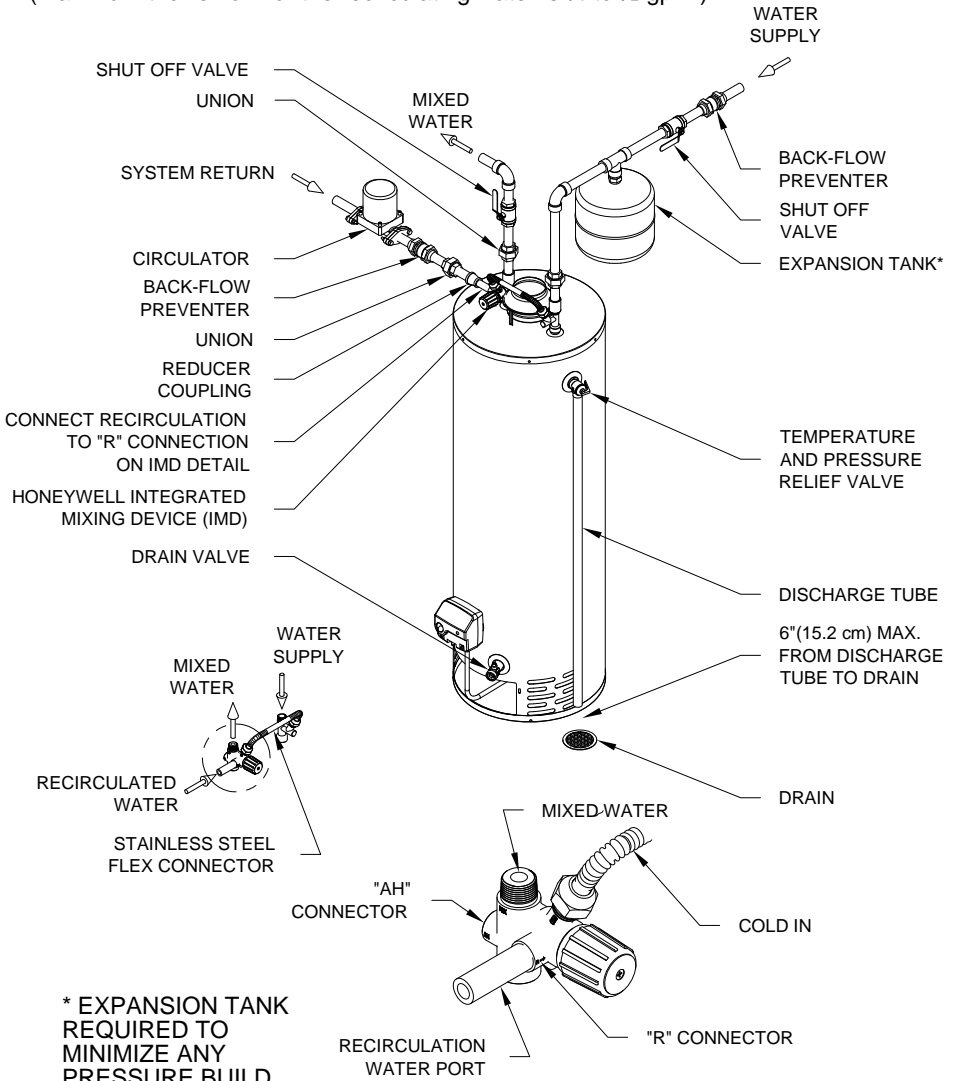

* EXPANSION TANK REQUIRED TO MINIMIZE ANY PRESSURE BUILD IF THE WATER SUPPLY PIPING HAS A BACK-FLOW PREVENTER, CHECK VALVE OR WATER METER WITH A CHECK VALVE.

Figure 10
RECIRCULATION SYSTEM

NOTES

NOTES